

THE THESIS OF THE DOCTORAL (PhD) DISSERTATION

JULIUS RAETHER

HUNGARIAN UNIVERSITY OF AGRICULTURE AND LIFE SCIENCES

KAPOSVÁR CAMPUS

2025



HUNGARIAN UNIVERSITY OF AGRICULTURE AND LIFE SCIENCES

**SUSTAINABILITY CHALLENGES AND CONSUMER
BEHAVIOUR IN OMNICHANNEL RETAILING:
EMPIRICAL EVIDENCE FROM THE CONSUMER
ELECTRONICS SECTOR**

JULIUS RAETHER

KAPOSVÁR, HUNGARY

2025

The PhD School

Name: Doctoral School of Economic and Regional Sciences

Discipline: Management and Organizational Sciences

Head: Prof. Dr. Zoltán Bujdosó, PhD

Full professor

Institute of Rural Development and Sustainable Economy

Hungarian University of Agriculture and Life Science

Supervisor: Prof. Dr. Viktória Szente, PhD

Full Professor

Faculty of Agriculture and Food Economics

Hungarian University of Agriculture and Life Science

.....
Approval of the School Leader

.....
Approval of the Supervisor

TABLE OF CONTENTS

LIST OF FIGURES	VI
LIST OF TABLES	VII
LIST OF ABBREVIATIONS.....	VIII
1 INTRODUCTION.....	1
1.1 Background and Motivation	1
1.2 Research problem and relevance	1
1.3 Objectives and research questions	2
1.4 Chapter overview and structure	4
2 THEORETICAL FOUNDATIONS AND LITERATURE REVIEW	4
2.1 Sustainability in omnichannel retailing.....	4
2.2 Consumer behaviour and sustainable consumption	5
2.3 The consumer electronics sector	6
2.4 Relevant theories.....	6
3 RESEARCH MODEL AND HYPOTHESES	7
4 METHODOLOGY	8
4.1 Research design	8
4.2 Data collection and sampling.....	9
4.3 Quantitative data analysis and validation	11
5 RESULTS	12
5.1 Results of the systematic literature review	12
5.2 Results of empirical studies	16
5.3 Integrated discussion of empirical findings.....	17
5.4 New scientific results	18
6 THEORETICAL AND PRACTICAL CONTRIBUTIONS	18
6.1 Theoretical Contributions.....	18
6.2 Methodological Contributions	19
6.3 Practical Implications.....	20

7 LIMITATIONS AND FUTURE RESEARCH	20
8 CONCLUSION	21
BIBLIOGRAPHY	IX
PUBLICATIONS	XVII

LIST OF FIGURES

Figure 1. Increasing numbers of publications in omnichannel retail with sustainability context on ScienceDirect, Scopus, and Emerald Insight	2
Figure 2. Structural model and the relationship of the hypotheses	8
Figure 3. Flow chart of the study selection process	10

LIST OF TABLES

Table 1. Research Questions.....	3
Table 2. Structure of the Dissertation.....	4
Table 3. Framework of challenges and key findings according to the three sustainability dimensions and (business) sectors.....	13
Table 4. Hypotheses Overview	16
Table 5. Overview of the new scientific results derived from the publications.....	18

LIST OF ABBREVIATIONS

CI	Channel Integration
CS	Customer Satisfaction
EA	Environmental Awareness
GBI	Green Brand Identity
GPI	Green Purchase Intention
PLS-SEM	Partial Least Squares Structural Equation Modelling
PRISMA	Preferred Reporting Items for Systematic Reviews and Meta-Analyses
SM	Sustainability Measures

1 INTRODUCTION

1.1 Background and Motivation

The advance of digital transformation and the growing relevance of sustainability have fundamentally reshaped the retail landscape, creating new opportunities but also major challenges for companies and consumers alike (Buldeo Rai, 2019; Hänninen et al., 2021; Sousa et al., 2021; Vhatkar et al., 2024). These challenges are particularly pronounced in omnichannel retailing, which depends on the seamless integration of physical and digital sales channels (Verhoef et al., 2015) while facing growing ecological, economic, and social demands. The consumer electronics industry illustrates this tension especially clearly. With its exceptionally high share of online sales, it is one of the sectors most strongly embedded in the omnichannel context (Olaf Roik, 2023). At the same time, it contributes significantly to environmental impacts due to short product life cycles, high resource and energy consumption, and complex return and recycling processes (Althaf et al., 2021; Li et al., 2015).

Given its strong omnichannel integration and considerable environmental footprint, the consumer electronics sector underscores the need for a deeper understanding of sustainability-related consumer behaviour in this context. Moreover, consumers are also placing increasing importance on sustainable brand management, environmental measures, and social responsibility in their purchasing decisions (Buldeo Rai, 2021; Nguyen & Johnson, 2020; Sousa et al., 2021). Despite numerous individual studies, there is still a lack of an integrated perspective that systematically links ecological, economic, and social challenges with consumer decision-making in this specific context. To address this need for a more comprehensive perspective, this dissertation systematically explores sustainability challenges in omnichannel retailing and investigates the role of individual and organisational factors in influencing sustainable purchasing decisions within the consumer electronics sector.

1.2 Research problem and relevance

Despite a growing number of studies on sustainability in omnichannel retail (Figure 1), there is still no consistent synthesis of the ecological, economic and social challenges, particularly from the consumer perspective. Previous studies have mainly focused on specific aspects such as delivery logistics, returns or technological integration (Elia et al., 2021; Melacini & Tappia, 2018; Muñoz-Villamizar et al., 2021; Sallnäs & Björklund, 2020; Sousa et al., 2021), without systematically linking these to consumer decisions. Furthermore, empirical evidence remains limited and fragmented on which combination individual (e.g. environmental awareness) and

organisational (company-driven) factors (e.g. channel integration) actually influences purchasing behaviour in the omnichannel context, and the few existing findings mainly originate from other sectors such as the apparel industry (Shao & Lassleben, 2021).

This dissertation addresses this research gap by combining a systematic literature review with a theory-based model development and by empirically testing the developed model in two separate studies. In this way, it provides a differentiated understanding of which combination of individual and organisational factors influences sustainable purchase intentions in omnichannel retailing within the consumer electronics sector.

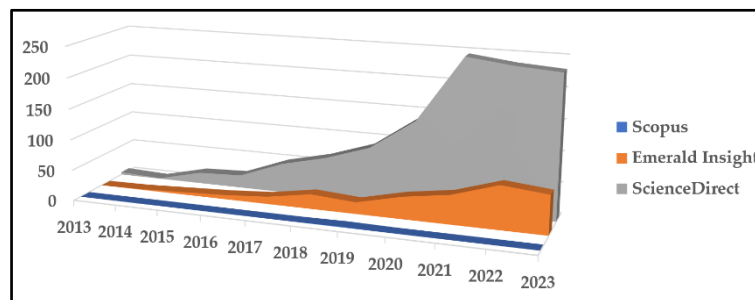

Figure 1. Increasing numbers of publications in omnichannel retail with sustainability context on ScienceDirect, Scopus, and Emerald Insight

1.3 Objectives and research questions

The overarching objective is to develop an integrated understanding of sustainability-related consumer behaviour in the context of omnichannel retailing, with a particular focus on the consumer electronics sector. To achieve this aim, the dissertation pursues three interconnected objectives.

The first objective is to systematically capture and structure the current state of research on sustainability challenges in omnichannel retailing. A systematic literature review identifies ecological, economic, and social challenges across the entire value chain. This review provides the contextual background that informs the subsequent empirical investigation.

The second objective is to develop a theory-driven structural model that builds on this contextual foundation while being derived from established theories and prior consumer behaviour research. The model focusses on how individual factors (environmental awareness and customer satisfaction) and organisational factors (green brand identity, channel integration and sustainability measures) are associated with sustainable purchasing behaviour in the consumer electronics sector.

The third objective is to empirically validate this model in two successive and closely connected studies. The pilot study tested and initially explored the hypotheses exploratively using PLS-SEM

(Partial Least Squares Structural Equation Modelling) with a smaller sample. The main then confirmed and refined the structural model with a larger sample using CB-SEM (Covariance-Based Structural Equation Modelling). This two-stage approach aims to strengthen the empirical foundation and enhances the generalisability of the findings.

Table 1 presents the research questions that build on the identified research gaps and objectives and guide this dissertation.

Table 1. Research Questions

	Research Questions	Context
1	What are the main sustainability challenges in omnichannel retailing from a consumer perspective, and how are these challenges addressed in the existing academic literature?	Addressed through a systematic literature review, structuring existing research on sustainability in omnichannel retail.
2	Which individual and organisational factors influence sustainable purchase intentions in the context of omnichannel retailing?	Explored in the empirical analyses. Factors such as environmental awareness, customer satisfaction, green brand identity, channel integration, and sustainability measures are examined.
3	To what extent do these individual and organisational factors influence consumer behaviour and sustainability-related purchasing behaviour?	Analysed in the empirical studies: Structural models analyse direct and indirect effects among influencing factors using structural equation modelling (SEM).
4	How do sector-specific characteristics of the consumer electronics industry shape sustainability-related consumer decision-making in omnichannel retail contexts?	Covered in the empirical studies: Only participants who had purchased a consumer electronics device within the last 24 months were eligible to take part in the survey.
5	How can the empirical findings in the consumer electronics sector be translated into practice-oriented recommendations for omnichannel retailers?	Derived from the discussion of findings from the in the empirical studie and formulated in the recommendations section.

1.4 Chapter overview and structure

The dissertation (main version) is divided into nine chapters and brings together theoretical foundations, a systematic literature review, and two empirical studies within one continuous framework (Table 2).

Table 2. Structure of the Dissertation

Chapter	Title	Description
Chapter 1	INTRODUCTION	Introduces the topic, background, motivation, research problem, and contribution.
Chapter 2	OBJECTIVES TO ACHIEVE	Defines objectives and research questions.
Chapter 3	LITERATURE OVERVIEW	Reviews literature on sustainability challenges, consumer behaviour, electronics sector, and theories; identifies gaps.
Chapter 4	RESEARCH MODEL AND HYPOTHESES	Develops the conceptual research model and formulates hypotheses based on theory.
Chapter 5	MATERIALS AND METHODS	Outlines research design, data sources, methods; describes literature review and empirical studies.
Chapter 6	RESULTS AND DISCUSSION	Presents and discusses results from literature review and empirical studies.
Chapter 7	CONCLUSIONS AND RECOMMENDATIONS	Summarises conclusions and practical recommendations.
Chapter 8	NEW SCIENTIFIC RESULTS	Highlights new empirical and methodological contributions.
Chapter 9	SUMMARY	Summarises the work

2 THEORETICAL FOUNDATIONS AND LITERATURE REVIEW

The theoretical foundations of this dissertation provide the conceptual background for the research model. This chapter first situates the topic within the academic discourse on sustainability in omnichannel retailing, examines aspects of consumer behaviour and sustainable consumption, highlights specific characteristics of the consumer electronics sector, and presents the key theoretical perspectives that frame the dissertation.

2.1 Sustainability in omnichannel retailing

Omnichannel retailing poses significant sustainability challenges for companies (Iglesias-Pradas & Acquila-Natale, 2023; Jena & Meena, 2022). The challenges in omnichannel retailing can be categorised into three dimensions under the concept of the Triple Bottom Line, which integrates ecological, economic, and social aspects of sustainability (Elkington, 1994).

From an ecological perspective, additional burdens arise due to fragmented supply chains, frequent partial shipments increased returns and the particularly emission-intensive last mile (Bosona,

2020; Buldeo Rai, 2021; Halldórsson & Wehner, 2020; Iglesias-Pradas & Acquila-Natale, 2023; Jena & Meena, 2022; Pourmohammadreza et al., 2025; Sousa et al., 2021). From an economic perspective, companies face the challenge of managing the complexity of integrated channels in omnichannel retailing while maintaining cost efficiency. Improving returns management, inventory control, and delivery logistics can help achieve operational efficiency gains and reduce environmental impacts simultaneously (Buldeo Rai et al., 2019b; Kayikci, 2018). The social dimension includes aspects such as fair working conditions along the supply chain, transparent communication or responsibility towards stakeholders (Sousa et al., 2021). Overall, sustainable omnichannel retailing requires the systematic integration of all three dimensions of the Triple Bottom Line along the entire value chain.

The sustainability challenges identified in the systematic literature review provide a solid foundation for structuring the relevant aspects in accordance with the environmental, economic, and social dimensions of the Triple Bottom Line in the context of omnichannel retailing. At the same time, this theoretical framework offers clear guidance for the precise classification and interpretation of the individual and organisational factors analysed in the empirical studies within this three-dimensional perspective.

2.2 Consumer behaviour and sustainable consumption

Consumer behaviour is gaining increasing significance in sustainability research and consumers emerging as drivers of sustainable innovation (Buldeo Rai, 2019; Galli et al., 2022; Jena & Meena, 2022). They are placing growing emphasis on environmentally friendly products and sustainable business practices, which are progressively being adopted in omnichannel retailing (Sousa et al., 2021). Previous studies identify several relevant factors influencing sustainable purchasing decisions, including price willingness (Bauer, 2021), ecological transport solutions (Buldeo Rai, 2021), consistent channel integration (Lee et al., 2019), and transparent and credible sustainability communication (Nguyen & Johnson, 2020). But the academic discourse shows that environmental awareness among consumers does not necessarily translate into sustainable consumption practices (Cao & Shao, 2021). This divergence between attitudes and actions is known as the attitude-behaviour gap (Boulstridge & Carrigan, 2000; Moraes et al., 2012). This dissertation empirically examines the attitude-behaviour gap by developing and testing an integrated model of sustainability-related purchasing decisions in omnichannel retailing, using quantitative data from the consumer electronics sector.

2.3 The consumer electronics sector

The consumer electronics sector comprises devices such as smartphones, laptops, televisions or household appliances and presents a particularly relevant field for sustainability-related research in omnichannel retailing. The consumer electronics market displays the typical characteristics of a highly digitalised sector with high online sales volumes (Gerling et al., 2025; Olaf Roik, 2023) and ubiquitous products such as smartphones. At the same time, this sector is considered resource-intensive and environmentally problematic (Althaf et al., 2021). Short product life cycles, the use of rare raw materials, complex production processes, and limited recycling options further exacerbate sustainability challenges. This combination of sector-specific sustainability challenges and cross-channel driven consumer behaviour highlights the consumer electronics sector as a particularly relevant domain for examining sustainability-related purchasing decisions in the context of omnichannel retailing, while also underscoring its practical significance for the omnichannel retail sector.

2.4 Relevant theories

The theoretical framework of this dissertation builds on several central concepts that integrate various perspectives on sustainability and consumer decision-making in omnichannel retailing. First, the concept of the Triple Bottom Line (Elkington, 1994) provides the framework for systematically capturing the ecological, economic, and social dimensions of sustainability. Second, Social Identity Theory (Tajfel & Turner, 1986) offers an explanation of how consumers align their purchasing behaviour with collective values and brand identification. This helps to understand why strong green brand identity, as an organisational factor, can encourage sustainable purchase intentions. Third, the attitude-behaviour gap is considered, which describes the phenomenon that positive environmental attitudes do not necessarily translate into sustainable consumption behaviour (Carrigan & Attalla, 2001; Zhuo et al., 2023). This dissertation addresses this tension by investigating to what extent environmental awareness is actually reflected in sustainable consumer decisions in omnichannel retailing for consumer electronics, and which organisational factors can help to narrow this gap. Fourth, the Theory of Planned Behaviour is used to explain the interplay between attitudes, intentions, and actual behaviour (Ajzen, 1991). It offers as a theoretical perspective to understand why consumers with pronounced environmental awareness may nevertheless act inconsistently in their purchasing choices, and how these patterns are shaped by perceived behavioural control and social norms. But this dissertation, the Theory of Planned Behaviour is not applied in its classical form and adapted and extended. Organisational factors

such as green brand identity, channel integration, and sustainability measures are incorporated to reflect the specific characteristics of omnichannel consumer electronics retailing.

Together, these theoretical perspectives form the conceptual framework of this dissertation and serve as the basis for developing the research model.

3 RESEARCH MODEL AND HYPOTHESES

Based on the theoretical foundations and the identified research gaps, an integrative structural model was developed (see Figure 2) to examine the individual and organisational factors influencing consumer behaviour and green purchase intention (GPI) in omnichannel retailing for consumer electronics. The model places particular emphasis on individual factors such as consumers' environmental awareness (EA), which is regarded as a key prerequisite for sustainable decisions, and customer satisfaction (CS), which reflects the perceived quality of the shopping experience. These are complemented by organisational factors that companies can actively shape, including consumers' green brand identity (GBI), the quality of channel integration (CI) across physical and digital touchpoints, and specific sustainability measures (SM) addressing ecological, economic, or social aspects.

The model assumes that these factors are interrelated in complex ways and exert both direct and indirect effects on green purchase intention (GPI). The classification of the factors partly reflects elements of the Theory of Planned Behaviour, adapted to the specific context of omnichannel consumer electronics retailing.

Based on these assumptions, the following hypotheses were formulated and tested in the empirical studies.

H1: Environmentally aware consumers perceive sustainable measures more positively.

H2: Environmental awareness positively influences customer satisfaction.

H3: Environmental awareness affects green purchase intention.

H4: Customer satisfaction positively influences green purchase intention.

H5: Sustainable measures in omnichannel retail with consumer electronics products positively influence customer satisfaction.

H6: Channel integration has a positive influence on customer satisfaction.

H7: Channel integration has a positive influence on green purchase intention.

H8: Green brand identity increases consumers' green purchase intention.

H9: Green brand identity positively influences customer satisfaction.

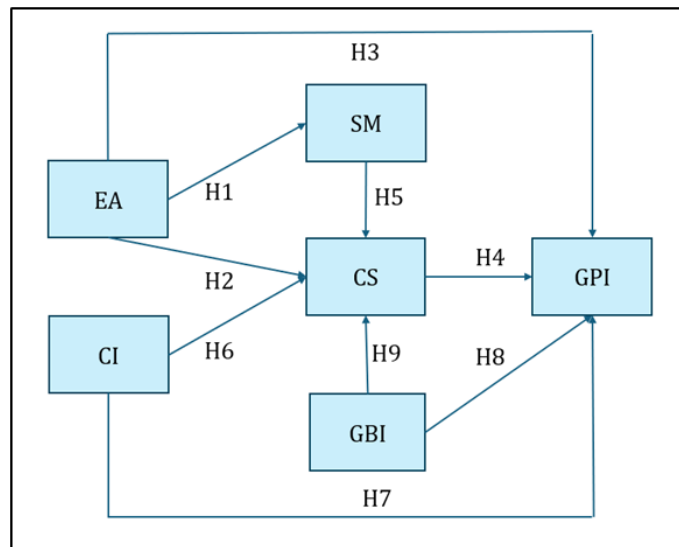

Figure 2. Structural model and the relationship of the hypotheses
Source: Author's own elaboration

Through the formulation and empirical testing of these hypotheses, the dissertation provides a theory-based and empirically validated contribution to understanding sustainability-related consumer behaviour in the omnichannel context of the consumer electronics sector.

4 METHODOLOGY

4.1 Research design

The methodological approach of this dissertation follows a multi-method design that combines systematic review and quantitative elements to enable a comprehensive understanding of sustainability-related challenges and consumer behaviour in omnichannel retailing. The research process consists of two complementary strands.

In the first step, a systematic literature review was conducted in accordance with the PRISMA (Preferred Reporting Items for Systematic Reviews and Meta-Analyses) guidelines (Moher et al., 2009; Page et al., 2021). The aim was to systematically identify, screen, and analyse relevant academic contributions from the past decade in order to capture ecological, economic, and social sustainability challenges in omnichannel retailing from the consumer perspective. This review provides the contextual background for the empirical parts of the dissertation. The hypotheses tested in the model are developed from established theoretical approaches and prior consumer behaviour research, addressing the influencing factors of environmental awareness, customer

satisfaction, green brand identification, channel integration, sustainability measures, and green purchase intention.

In the second step, two successive and interrelated empirical studies were applied to develop, test, and validate the structural model. In the pilot study, the PLS-SEM method was adopted to estimate the assumed relationships and to test the measurement instruments in an exploratory manner. This enabled the theoretical assumptions to be tested empirically for the first time and the measurement instruments to be validated. In the main study, a substantially larger sample was used to validate the structural model and to ensure the generalisability of the findings. CB-SEM was employed to analyse direct and indirect effects between environmental awareness, customer satisfaction, green brand identity, channel integration, sustainability measures, and green purchase intention.

4.2 Data collection and sampling

The data basis of this dissertation consists of a systematic literature review and two empirical online surveys.

In the first step, a systematic literature review was conducted in accordance with the PRISMA guidelines. The aim was to systematically identify, screen, and analyse relevant academic publications from the past decade in order to capture ecological, economic, and social sustainability challenges in omnichannel retailing. The analysis followed a four-stage process in which relevant articles were identified through a systematic search of the databases ScienceDirect, Scopus, and Emerald Insight, covering publications from 2013 to 2023. Targeted keyword combinations were applied, including various spellings of “omnichannel retailing” along with the terms “sustainability” and “consumers”. The results were screened based on titles, abstracts, and keywords to exclude irrelevant contributions. Full texts were then assessed for alignment with predefined inclusion criteria, such as a focus on omnichannel retail and sustainability. In the final step, the relevant studies were selected for detailed analysis. In total, 1390 articles were initially identified, of which 18 articles were included finally in this systematic literature review (see Figure 3).

For the empirical investigation, an online survey was conducted in February 2025 using SurveyMonkey. The target group for the pilot study consisted of 125 German consumers who had purchased at least one electronic consumer good (e.g., smartphones, notebooks, cameras, or household appliances) from an omnichannel retailer within the past 24 months. A screening questionnaire was used to ensure that only qualified participants were included in the sample. In the subsequent main study, a total of 358 valid data sets were available for the analysis. The questionnaire used in the study was based on theoretically grounded and empirically validated

scales from the relevant academic literature, adapted to the specific research context. All items were measured using five-point Likert scales.

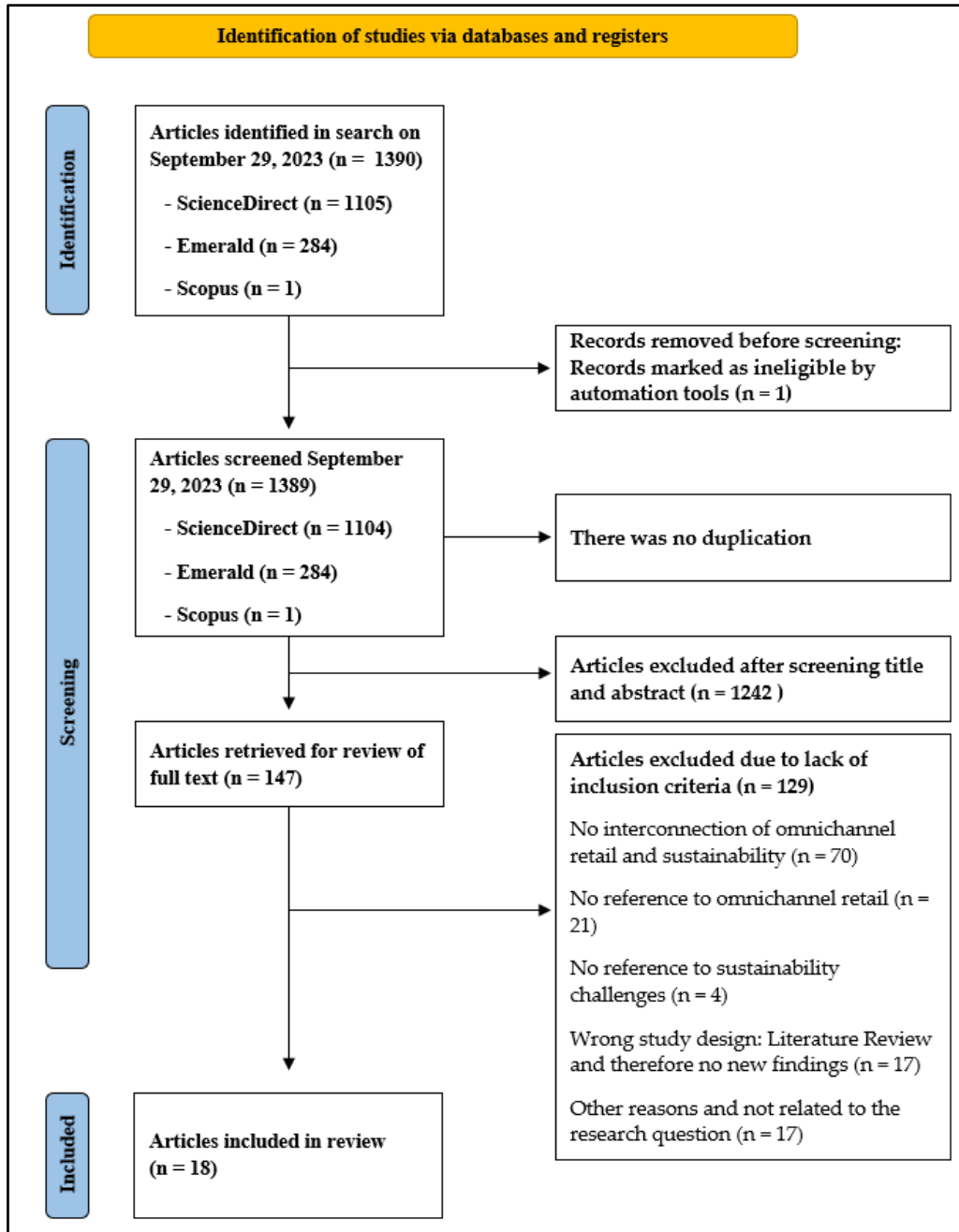

Figure 3. Flow chart of the study selection process
Source: Author's own elaboration

4.3 Quantitative data analysis and validation

The quantitative data analysis followed a two-step approach using established structural equation modelling (SEM) techniques to systematically test the hypotheses derived from the research model.

In the pilot study, PLS-SEM was applied, as it is particularly suitable for exploratory analyses with small samples and complex models with multiple latent variables (Fauzi, 2022; Hair et al., 2017). Calculations were conducted with the software SmartPLS 3. Key indicators included path coefficients, R^2 values, average variance extracted (AVE), and composite reliability. Measurement quality was assessed by examining convergent and discriminant validity according to the Fornell-Larcker criterion, internal consistency was verified using Cronbach's alpha and composite reliability, and the HTMT criterion. The model fit was further assessed through the Standardized Root Mean Square Residual (SRMR) and the Normed Fit Index (NFI). In addition, bootstrapping was applied to generate t-statistics and p-values for testing the significance of the estimated relationships.

Building on these exploratory results, the main study used CB-SEM to confirm and validate the structural model with the larger sample. The calculations were performed in the statistical software R using the lavaan and semTools packages. Model fit was assessed using established indices such as the Comparative Fit Index (CFI), Tucker-Lewis Index (TLI), and Root Mean Square Error of Approximation (RMSEA). Furthermore, convergent validity (factor loadings, AVE), internal consistency (Cronbach's alpha, composite reliability), and sampling adequacy (KMO test) were examined to ensure measurement validity.

In addition, a mediator analysis was conducted in both empirical studies to reveal indirect effects within the model. This step enabled a differentiated view of how individual and organisational factors interact to influence green purchase intention in an omnichannel context. The combined use of PLS-SEM and CB-SEM allowed the hypotheses to be tested, both exploratively and confirmatorily, thereby ensuring the methodological robustness of the results.

5 RESULTS

This dissertation combines a systematic literature review with two successive empirical studies, offering a multidimensional perspective on sustainability-related challenges and consumer decision-making processes within the omnichannel retail environment.

5.1 Results of the systematic literature review

The systematic literature review forms the conceptual basis of this dissertation. Its aim was to structure existing research on ecological, economic and social challenges in omnichannel retail from a consumer perspective and to identify existing research gaps. The literature review reveals that sustainability in omnichannel retailing has thus far been predominantly examined from a corporate perspective, with a strong emphasis on economic and ecological aspects, particularly in the areas of logistics, transportation, and last mile delivery. In contrast, social dimensions and consumer perspectives remain significantly underrepresented. Moreover, the review highlights the lack of an overarching synthesis of existing sustainability challenges in the omnichannel context, a gap that this review directly addresses.

In total, 66 findings were identified, with 23 relating to the environmental dimension, 31 to the economic dimension and 12 to the social dimension. These findings are distributed across the clusters Logistics (15 findings), Last Mile (34 findings), Business Operations and Information Technology (15 findings) and Customer (2 findings), as summarised in Table 3

Table 3. Framework of challenges and key findings according to the three sustainability dimensions and (business) sectors

	Challenges/Key findings			Count
	Environment	Economic	Social	
Logistics	<ul style="list-style-type: none"> ● Returns generate more waste and energy resources (Bijmolt et al., 2021; Sallnäs & Björklund, 2020). ● High environmental impact caused by fast shipping (Muñoz-Villamizar et al., 2021). ● Packaging waste (Adivar et al., 2019; Sallnäs & Björklund, 2020) ● Lenient returns policy leads to more returns and has a negative impact on the environment (Karlsson et al., 2023). ● Increased energy and resource consumption in omnichannel retailing with longer transport routes, more complex packaging, reduced basket sizes and higher return rates for online orders (Buldeo Rai, 2021; Xu et al., 2023) 	<ul style="list-style-type: none"> ● Decentralized omnichannel networks to improve sustainability when allocating the shipping location (Kembro & Norrman, 2019). ● Failed home deliveries of food purchased online due to the perishable nature of the goods (Pan et al., 2017). ● Lenient returns policy weakens profitability (Karlsson et al., 2023). ● Lack of planning to optimize the transport of goods to the final customer (scheduling, delivery window) (Sallnäs & Björklund, 2020) ● Poor exchange on packaging design between omnichannel retailer and logistic providers (Sallnäs & Björklund, 2020). 	<ul style="list-style-type: none"> ● Eco-friendly delivery methods increase brand visibility and customer loyalty (Kembro & Norrman, 2019). ● Health (disease caused by transport side effects like pollution or noise or accident rates) (Kayikci, 2018). ● Consumers tend to choose express deliveries with a poor environmental performance (Sallnäs & Björklund, 2020). ● Little influence of consumers on the greening of distributions (Sallnäs & Björklund, 2020). 	15
	6	5	4	
Last mile	<ul style="list-style-type: none"> ● Inefficient last mile routings affect the environment (Bergmann et al., 2020; Buldeo Rai et al., 2019b, 2021; Hagberg & Hulthén, 2022). ● Delivering goods collectively as close as possible to the point of consumption relieves the environment (Halldórsson & Wehner, 2020). ● Omnichannel retail executives still pay too little attention to sustainability 	<ul style="list-style-type: none"> ● High energy demand on the last mile (Bijmolt et al., 2021; Buldeo Rai, 2021; Buldeo Rai et al., 2019b; Hagberg & Hulthén, 2022; Halldórsson & Wehner, 2020; Kembro & Norrman, 2019; Risberg & Jafari, 2022). ● Last mile most expensive delivery leg (Bijmolt et al., 2021; Buldeo Rai et al., 2019b, 2021; Halldórsson & Wehner, 2020; Kembro & Norrman, 2019; Risberg & Jafari, 2022). 	<ul style="list-style-type: none"> ● Limited interest of customers in more eco-friendly transport options (Buldeo Rai et al., 2019b, 2021). But they also prefer the greatest possible delivery transparency (Buldeo Rai et al., 2021). 	

	<p>aspects (Kembro & Norrman, 2019; Risberg & Jafari, 2022).</p> <ul style="list-style-type: none"> • Food vans of OCR (Omnichannel retailer) in the UK lead to more traffic congestion, noise pollution and increased space requirements (but better environmental performance than deliveries by pure online providers or centralised retailers) (Kembro & Norrman, 2019). • Sustainability deficits due to a lack of cooperation and information exchange between logistics service providers and authorities (Buldeo Rai et al., 2019a) and deliveries with non-environmentally-friendly vehicles (Buldeo Rai et al., 2019a; Hagberg & Hulthén, 2022). 	<ul style="list-style-type: none"> • Cooperations with logistics services providers to achieve fossil-free (Buldeo Rai, 2021) deliveries (Risberg & Jafari, 2022). • Offering customers different/better prices for more sustainable-friendly delivery options (Risberg & Jafari, 2022). • Increased efficiency by combining pick-up and delivery processes on the last and first mile. (Bergmann et al., 2020) • Collection and delivery within a local network, e.g. collection points or hand over to the neighbour as a solution to increase efficiency (Buldeo Rai et al., 2021). • Efficiency deficits due to a lack of cooperation and information exchange between logistics service providers and authorities (Buldeo Rai et al., 2019a) and deliveries with non-environmentally-friendly vehicles (Buldeo Rai et al., 2019a; Hagberg & Hulthén, 2022). • Increased returns rates in OCR weaken profitability (Hagberg & Hulthén, 2022). • Public transport requirements, e.g. for packaging, cooling, hazardous goods (Hagberg & Hulthén, 2022) 		
	11	20	3	34
Business Operations & Information Technology	<ul style="list-style-type: none"> • High environmental impact of the clothing industry (Bilińska-Reformat & Dewalska-Opitek, 2021). • Resource efficiency (waste, pollution, land use impact) (Kayikci, 2018) • Increasing parcel volume due to OCR (Buldeo Rai et al., 2019a) and almost unlimited access to products worldwide is an environmental challenge (He et al., 2023) • Different national guidelines for market participants make it more 	<ul style="list-style-type: none"> • Reduction of the carbon footprint in fast fashion (Bilińska-Reformat & Dewalska-Opitek, 2021). • Reducing waste, air pollution and greenhouse gas emissions is more likely to be met through the use of digital technologies (delivery time, delay, inventory, reliability) (Kayikci, 2018). • Improving delivery distances (3-20%) and delivery rates (18-26%) with computer simulations (Pan et al., 2017). • Coordination of the omnichannel supply chain towards greater energy efficiency is difficult due to 	<ul style="list-style-type: none"> • Almost unlimited availability to products in an online/OCR setting increases the demand to buy more (Buldeo Rai, 2021; He et al., 2023) and the number of purchases or shopping trips on the consumer side (Hagberg & Hulthén, 2022). • Environmentally aware customers pay more attention to packaging- 	

	<p>challenging to reduce CO2 emission (He et al., 2023)</p> <ul style="list-style-type: none"> ● Omnichannel leads to less packaging materials than the pure-online channel (Peng et al., 2022). 	<p>the different requirements and interests of market participants (He et al., 2023).</p> <ul style="list-style-type: none"> ● An optimal store density helps to increase profits (Peng et al., 2022). ● CO2 regulations and taxes are a financial burden for omnichannel retailer (Xu et al., 2023). 	<p>friendly pickup services but store pickups are tendentially inconvenient to customers (Peng et al., 2022)</p>	
	6	6	3	15
Costumer			<ul style="list-style-type: none"> ● Swedish customers are already more environmentally aware than retailers' executives (Risberg & Jafari, 2022). ● Enhanced consumer awareness of employment rights in the fast fashion industry (Bilińska-Reformat & Dewalska-Opitek, 2021). 	
	0	0	2	2
Total	23	31	12	66

5.2 Results of empirical studies

The empirical strand of the dissertation complement these findings by introducing a data-driven perspective and explicitly addressing the underexplored social dimension. It examines how individual factors (environmental awareness and customer satisfaction) and organisational factors (sustainability measures, channel integration, and green brand identity) influence consumer behaviour and green purchase intention in the consumer electronics sector within the context of omnichannel retailing. The results of the two empirical studies provide a complementary picture of the hypothesised relationships, shown in Table 4.

Table 4. Hypotheses Overview

Hypothesis	Relationship	Significant (Pilot study)	Significant (Main study)
H1	EA → SM	✓	✓
H2	EA → CS	-	-
H3	EA → GPI	Marginal	✓
H4	CS → GPI	-	-
H5	SM → CS	-	-
H6	CI → CS	✓	✓
H7	CI → GPI	-	-
H8	GBI → GPI	✓	✓
H9	GBI → CS	-	-

Environmental awareness emerged in both analyses as a key factor for the perception of sustainable measures (H1), confirming that environmentally aware consumers in the consumer electronics sector tend to prefer companies that demonstrate their commitment to sustainability. The direct effect of environmental awareness on green purchase intention (H3) was only marginally significant in the pilot study but was confirmed as significant in the main study. This difference reflects the smaller sample size and also the exploratory nature of the pilot study in contrast to the confirmatory strength of the main study. However, no relationship was found between environmental awareness and customer satisfaction (H2) or between sustainability measures and customer satisfaction (H5). Similarly, the direct effect of customer satisfaction on green purchase intention (H4) remained insignificant in both studies, as did the indirect effects via customer satisfaction.

In contrast, channel integration consistently showed a positive influence on customer satisfaction (H6), although its direct effect on green purchase intention (H7) could not be

confirmed. Regarding green brand identity, the data revealed a significant positive effect on green purchase intention (H8) but no significant effect on customer satisfaction (H9).

The empirical results emphasises the central role of environmental awareness and green brand identity as key drivers of sustainable consumer behaviour. These findings are further interpreted and contextualised in the subsequent discussion.

5.3 Integrated discussion of empirical findings

Taken together, the findings of the two empirical studies indicate that green purchase intention in omnichannel retailing for consumer electronics is primarily driven directly by environmental awareness and green brand identity. Both factors directly influence the perception of sustainability measures (H1) as well as green purchase intention (H3, H8), underlining their central importance. The pilot study indicated only a marginal effect of environmental awareness on green purchase intention (H3), whereas the main study confirmed a clear significant effect, underscoring the robustness of this relationship.

At the same time, the results put earlier assumptions about customer satisfaction into perspective. Neither a direct influence on green purchase intention (H4) nor indirect effects (via H2, H5) could be proven. The results therefore reveal that customer satisfaction does not operate as a mediator between sustainability-related factors and green purchase intention in this context, which contrasts partly from assumptions from other consumer behaviour models and industries. Similarly, the direct relationship between channel integration and green purchase intention remained unproven (H7), whereas the positive effect of channel integration on customer satisfaction was confirmed (H6).

The results show that consumers expect seamless channel integration, but that this alone does not lead to sustainable purchasing decisions. Instead, green purchase behaviour is primarily shaped by values and identification (environmental awareness and green brand identity), while functional aspects (customer satisfaction and channel integration) play only a supplementary role. Only the combination of individual environmental awareness, clearly communicated sustainability measures, and a consistent green brand identity demonstrates a measurable influence on green purchase intention. The findings underline that sustainability in the consumer electronics sector should not be treated merely as an operational task but integrated strategically into brand positioning to effectively reach environmentally aware consumers.

5.4 New scientific results

The new scientific results of this dissertation are summarised in Table 5, highlighting theoretical, empirical, and methodological contributions.

Table 5. Overview of the new scientific results derived from the publications

No.	Result	Novelty	Reference
1	Structured systematisation of sustainability challenges in omnichannel retailing	First systematic literature review in this field across ecological, economic, and social dimensions, applying the PRISMA method, and highlighting underrepresented social and consumer-related aspects.	Systematic Literature Review
2	Development of a structured model to explain sustainable purchase decisions in the consumer electronics sector.	First integrative structural model combining individual and organisational factors in the context of omnichannel consumer electronics retailing.	Empirical Study
3	Channel integration increases customer satisfaction without directly influencing sustainable purchase intention	Provides a new perspective on the interplay of technical and emotional factors by differentiating between functional and value-based impact pathways in consumer behaviour.	Empirical Study

6 THEORETICAL AND PRACTICAL CONTRIBUTIONS

6.1 Theoretical Contributions

This dissertation makes several theoretical contributions to the study of sustainability-related consumer behaviour in omnichannel retailing, specifically in the consumer electronics sector, which has so far received little attention in this combination.

The systematic literature review contributes to the systematisation of the research field by providing a structured overview of existing sustainability challenges in omnichannel retailing through the application of the PRISMA method and demonstrates that these challenges have predominantly been examined from a company perspective, while an integrated consumer perspective has largely been lacking. In contrast to previous reviews that often adopted fragmented perspectives, this analysis offers an integrative view of ecological, economic, and social challenges across the entire value chain, thereby establishing a theoretical foundation on which future research can systematically build.

Furthermore, this dissertation expands existing models of sustainable consumer behaviour by adding a specific focus on the consumer electronics sector, which has so far been underrepresented in the literature. The two empirical studies broaden this understanding by

systematically demonstrating for the first time how individual factors such as environmental awareness and organisational factors such as green brand identity directly influence green purchase intention in the technology-driven consumer electronics sector. This finding underlines the relevance of value-based drivers in contrast to purely functional factors. At the same time, empirical analysis also refines the current state of research, which has mostly focused on industries such as fashion (see (Shao & Lassleben, 2021)). In addition, it shows that functional factors such as channel integration primarily enhance customer satisfaction in the consumer electronics context but are not decisive for sustainable purchasing decisions on their own.

Beyond these sector-specific contributions, the dissertation also connects the findings to broader theoretical perspectives. The Triple Bottom Line provides the overarching lens for clustering ecological, economic, and social dimensions. The Social Identity Theory explains the role of green brand identity in aligning consumer values with sustainable brand positioning. And the Theory of Planned Behaviour serves as a reference point for interpreting the attitude-behaviour gap. Its main components attitude (expressed through environmental awareness), subjective norms (reflected in green brand identity), and perceived behavioural control (represented by channel integration and sustainability measures), help to explain under which conditions environmental attitudes translate into green purchase intention.

6.2 Methodological Contributions

Methodologically, this dissertation illustrates the suitability of multi-method designs for addressing complex research questions at the intersection of omnichannel retailing, sustainability and consumer electronics. The systematic literature review conducted according to PRISMA guidelines provides a robust foundation and reveals current sustainability challenges.

The combination of exploratory PLS-SEM and confirmatory CB-SEM in the pilot and main study demonstrates that integrating both SEM approaches supports the validation of theoretical assumptions while capturing industry-specific characteristics in consumer electronics. This methodological approach therefore offers a transferable framework for future studies on consumer behaviour in technology-driven sectors.

6.3 Practical Implications

The systematic literature review offers a structured overview of ecological, economic and logistical challenges, but as it does not generate primary data, its role for practical implications is complementary. The practical implications of this dissertation are mainly derived from the pilot and main study.

First, the empirical studies show that environmental awareness directly influences both the perception of sustainability measures and green purchase intention. Omnichannel retailers should therefore specifically address environmentally aware customers through CO₂-neutral delivery options, take-back and recycling programmes, or transparent product information, and communicate these measures clearly across all channels. Second, the strong effect of green brand identity on green purchase intention confirms that sustainability must be firmly embedded in the brand positioning and consistently communicated across all touchpoints. Credible messages and verifiable actions build trust and foster long-term loyalty among environmentally aware consumers. This finding also aligns with previous research beyond the consumer electronics context (Chen et al., 2020; Sarinya L. Suttharatanagul et al., 2025; Siyal et al., 2021). Third, the results indicate that while channel integration enhances customer satisfaction, it does not have a direct impact on green purchase intention. Seamless processes and flexible services remain important but must be linked with credible sustainability communication. Fourth, the absence of a direct effect of customer satisfaction and sustainability measures on green purchase intention suggests that technical or functional offerings alone are insufficient to drive sustainable purchase behaviour. Sustainability measures should be visibly embedded in the omnichannel customer journey and aligned with individual values. For example, the added value of an eco-friendly shipping option can be enhanced by displaying concrete CO₂ savings during checkout.

Overall, the findings demonstrate that in the consumer electronics sector, sustainability should not only be implemented operationally but strategically anchored in brand management in order to reliably translate positive environmental attitudes into sustainable purchasing decisions and to build long-term loyalty among environmentally conscious customer segments.

7 LIMITATIONS AND FUTURE RESEARCH

Despite the robust theoretical and empirical contributions of this dissertation, several research-related limitations should be considered when interpreting the findings. The systematic

literature review is limited to English-language publications from three databases, which may lead to an underrepresentation of regional perspectives or relevant studies in other languages. In addition, the focus on the search terms “sustainability” and “omnichannel” may have excluded related topics such as “green retail” or “circular economy”.

The empirical studies are based solely on samples from Germany and concentrate specifically on consumers in the omnichannel consumer electronics sector. This geographical and industry-specific focus limits the generalisability of the results to other contexts. Furthermore, the exclusive use of standardised online surveys may introduce biases such as self-selection or socially desirable response behaviour. Furthermore, the operationalisation of the Theory of Planned Behaviour was limited. Subjective norms and perceived behavioural control were only captured indirectly and actual purchasing behaviour was not measured. Finally, the exclusive focus on consumers leaves out the retailer perspective, which restricts insights into strategic or organisational trade-offs.

Future research should therefore include comparative studies in other countries to capture cultural differences in sustainability-related consumer behaviour in omnichannel retailing. Qualitative approaches such as in-depth interviews or focus groups could help to better understand the psychological and social mechanisms behind the interplay of the different determinants shaping green purchase intentions. Extending the model to include additional factors offers also further potential for deeper analysis. Moreover, a segmentation by generations or customer groups, considering post-purchase behaviours such recycling or a more complete application of the Theory of Planned Behaviour also represent promising directions for future research.

8 CONCLUSION

This dissertation provides an integrated contribution to understanding sustainability-related consumer behaviour in omnichannel retailing, with a particular focus on the consumer electronics sector. By combining a systematic literature review with two empirical studies, this work addresses a significant research gap by examining both the ecological, economic and social challenges of sustainable omnichannel retailing and the individual and organisational factors that shape sustainable purchase intentions.

The starting point was a systematic literature review conducted according to PRISMA guidelines, which demonstrates that sustainability in the omnichannel context has so far been

analysed primarily from a company-centred perspective. While economic and ecological challenges, especially in transport and logistics, have received significant attention, social and consumer-related dimensions remain largely underexplored. By systematically categorising these challenges along the Triple Bottom Line perspective, the review provides a robust theoretical foundation and identifies key research gaps.

Building on this foundation, the empirical analyses offer robust insights into the factors that actually shape sustainable consumer behaviour in the technology-driven consumer electronics sector. The results show that individual, value-based factors, in particular environmental awareness and green brand identity, have a significant direct effect on green purchase intention. Functional aspects, such as seamless channel integration, clearly enhance customer satisfaction but do not directly lead to sustainability-driven purchasing decisions. The assumption that higher customer satisfaction automatically results in stronger purchase intentions could not be confirmed for this specific sector.

Theoretical contributions of this dissertation enhance the understanding of sustainability-related consumer behaviour in the context of omnichannel retailing. It offers a structured systematisation of the research field at the intersection of sustainability and omnichannel retailing, applies established behavioural models from related domains to the consumer electronics sector for the first time, and integrates both individual and organisational factors within a coherent analytical framework. Furthermore, the combination of exploratory and confirmatory approaches to structural equation modelling enhances the explanatory power and validity of the empirical findings.

From a practical perspective, the results indicate that sustainability strategies in omnichannel retailing should not focus solely on technical or logistical aspects. Instead, greater emphasis should be placed on credible brand management, consistent communication of sustainable values, and their integration into a coherent, omnichannel customer journey.

Despite these clear empirical contributions, this dissertation also highlights the need for further research. The geographic focus on Germany and the exclusive use of standardised online surveys limit the generalisability of the findings. International comparative studies and qualitative approaches could help to capture cultural differences more effectively and provide deeper insights into the psychological mechanisms of sustainable consumer behaviour in omnichannel retailing. Extending the research model to include additional factors would also offer further potential for deeper analysis.

In conclusion, this dissertation makes a substantial contribution to closing an existing research gap at the interface of sustainability, omnichannel retailing and consumer electronics. It provides a solid theoretical and empirical basis for further research and practice, offering concrete guidance for the development of credible sustainability strategies that meet the expectations of an increasingly environmentally aware customer base in the consumer electronics sector within an omnichannel retailing context.

BIBLIOGRAPHY

- Adivar, B., Hüseyinoğlu, I. Ö. Y., & Christopher, M. (2019). A quantitative performance management framework for assessing omnichannel retail supply chains. *Journal of Retailing and Consumer Services*, 48, 257–269.
<https://doi.org/10.1016/j.jretconser.2019.02.024>
- Ajzen, I. (1991). The theory of planned behavior. *Organizational Behavior and Human Decision Processes*, 50(2), 179–211. [https://doi.org/10.1016/0749-5978\(91\)90020-T](https://doi.org/10.1016/0749-5978(91)90020-T)
- Althaf, S., Babbitt, C. W., & Chen, R. (2021). The evolution of consumer electronic waste in the United States. *Journal of Industrial Ecology*, 25(3), 693–706.
<https://doi.org/10.1111/jiec.13074>
- Bauer, A. (2021). Consumer Electronics in Europe: More than half of buyers are prepared to spend more for a sustainable product, 2021.
https://www.quantilope.com/hubfs/Q%20-%20Marketing%20internal/Website/download-files/210525_PR-Study-Consumer-Electronics-EU-EN.pdf
- Bergmann, F. M., Wagner, S. M., & Winkenbach, M. (2020). Integrating first-mile pickup and last-mile delivery on shared vehicle routes for efficient urban e-commerce distribution. *Transportation Research Part B: Methodological*, 131, 26–62.
<https://doi.org/10.1016/j.trb.2019.09.013>
- Bijmolt, T. H., Broekhuis, M., Leeuw, S. de, Hirche, C., Rooderkerk, R. P., Sousa, R., & Zhu, S. X. (2021). Challenges at the marketing–operations interface in omni-channel retail environments. *Journal of Business Research*, 122, 864–874.
<https://doi.org/10.1016/j.jbusres.2019.11.034>
- Bilińska-Reformat, K., & Dewalska-Opitek, A. (2021). E-commerce as the predominant business model of fast fashion retailers in the era of global COVID 19 pandemics.

Procedia Computer Science, 192, 2479–2490.

<https://doi.org/10.1016/j.procs.2021.09.017>

Bosona, T. (2020). Urban Freight Last Mile Logistics—Challenges and Opportunities to

Improve Sustainability: A Literature Review. *Sustainability*, 12(21), 8769.

<https://doi.org/10.3390/su12218769>

Boulstridge, E., & Carrigan, M. (2000). Do consumers really care about corporate

responsibility? Highlighting the attitude—Behaviour gap. *Journal of Communication*

Management, 4(4), 355–368. <https://doi.org/10.1108/eb023532>

Buldeo Rai, H. (2019). Environmental sustainability of the last mile in omnichannel retail.

<https://researchportal.vub.be/en/publications/environmental-sustainability-of-the-last-mile-in-omnichannel-reta>

Buldeo Rai, H. (2021). The net environmental impact of online shopping, beyond the

substitution bias. *Journal of Transport Geography*, 93, 103058.

<https://doi.org/10.1016/j.jtrangeo.2021.103058>

Buldeo Rai, H., Verlinde, S., & Macharis, C. (2019a). City logistics in an omnichannel

environment. The case of Brussels. *Case Studies on Transport Policy*, 7(2), 310–317.

<https://doi.org/10.1016/j.cstp.2019.02.002>

Buldeo Rai, H., Verlinde, S., & Macharis, C. (2019b). The “next day, free delivery” myth

unravelling. *International Journal of Retail & Distribution Management*, 47(1), 39–54.

<https://doi.org/10.1108/IJRDM-06-2018-0104>

Buldeo Rai, H., Verlinde, S., & Macharis, C. (2021). Who is interested in a crowdsourced last

mile? A segmentation of attitudinal profiles. *Travel Behaviour and Society*, 22, 22–31.

<https://doi.org/10.1016/j.tbs.2020.08.004>

- Cao, H., & Shao, P. (2021). Impact of environmental attitude and materialism on apparel disposal intention. *Journal of Physics: Conference Series*, 1790(1), 12095. <https://doi.org/10.1088/1742-6596/1790/1/012095>
- Carrigan, M., & Attalla, A. (2001). The myth of the ethical consumer – do ethics matter in purchase behaviour? *Journal of Consumer Marketing*, 18(7), 560–578. <https://doi.org/10.1108/07363760110410263>
- Chen, Y.-S., Chang, T.-W., Li, H.-X., & Chen, Y.-R. (2020). The Influence of Green Brand Affect on Green Purchase Intentions: The Mediation Effects of Green Brand Associations and Green Brand Attitude. *International Journal of Environmental Research and Public Health*, 17(11), 4089. <https://doi.org/10.3390/ijerph17114089>
- Elia, S., Giuffrida, M., Mariani, M. M., & Bresciani, S. (2021). Resources and digital export: An RBV perspective on the role of digital technologies and capabilities in cross-border e-commerce. *Journal of Business Research*, 132, 158–169. <https://doi.org/10.1016/j.jbusres.2021.04.010>
- Elkington, J. (1994). Enter the Triple Bottom Line, 1994. <https://johnelkington.com/archive/TBL-elkington-chapter.pdf>
- Fauzi, M. A. (2022). Partial least square structural equation modelling (PLS-SEM) in knowledge management studies: Knowledge sharing in virtual communities. *Knowledge Management & E-Learning: An International Journal*, 103–124. <https://doi.org/10.34105/j.kmel.2022.14.007>
- Galli, M., Sebastiani, R., & Anzivino, A. (2022). Sustainability and Omnichannel Strategies in the Italian Wine Industry. *Corporate Responsibility, Sustainability and Markets*, 31–51. https://doi.org/10.1007/978-3-030-79660-0_3

- Gerling, M., Roik, O., Petras, A., Sievers, M., & Fetsch, S. (2025). *Trends im Einzelhandel*.
<https://einzelhandel.de/themeninhalte/konjunkturundmarktdaten/940-publikationen/714-broschueren/3902-studie-trends-im-handel-2025>
- Hagberg, J., & Hulthén, K. (2022). Consolidation through resourcing in last-mile logistics. *Research in Transportation Business & Management*, 45, 100834.
<https://doi.org/10.1016/j.rtbm.2022.100834>
- Hair, J. F., Hult, G. T. M., Ringle, C. M., & Sarstedt, M. (2017). *A primer on partial least squares structural equation modeling (PLS-SEM)* (Second edition). Sage.
https://eli.johogo.com/Class/CCU/SEM/_A%20Primer%20on%20Partial%20Least%20Squares%20Structural%20Equation%20Modeling_Hair.pdf
- Halldórsson, Á., & Wehner, J. (2020). Last-mile logistics fulfilment: A framework for energy efficiency. *Research in Transportation Business & Management*, 37, 100481.
<https://doi.org/10.1016/j.rtbm.2020.100481>
- Hänninen, M., Kwan, S. K., & Mitronen, L. (2021). From the store to omnichannel retail: looking back over three decades of research. *The International Review of Retail, Distribution and Consumer Research*, 31(1), 1–35.
<https://doi.org/10.1080/09593969.2020.1833961>
- He, X., Jiang, J., & Hu, W. (2023). Cross effects of government subsidies and corporate social responsibility on carbon emissions reductions in an omnichannel supply chain system. *Computers & Industrial Engineering*, 175, 108872.
<https://doi.org/10.1016/j.cie.2022.108872>
- Iglesias-Pradas, S., & Acquila-Natale, E. (2023). The Future of E-Commerce: Overview and Prospects of Multichannel and Omnichannel Retail. *Journal of Theoretical and Applied Electronic Commerce Research*, 18(1), 656–667.
<https://doi.org/10.3390/jtaer18010033>

- Jena, S. K., & Meena, P. (2022). Competitive sustainable processes and pricing decisions in omnichannel closed-up supply chains under different channel power structures. *Journal of Retailing and Consumer Services*, *69*, 103114. <https://doi.org/10.1016/j.jretconser.2022.103114>
- Karlsson, S., Oghazi, P., Hellstrom, D., Patel, P. C., Papadopoulou, C., & Hjort, K. (2023). Retail returns management strategy: An alignment perspective. *Journal of Innovation & Knowledge*, *8*(4), 100420. <https://doi.org/10.1016/j.jik.2023.100420>
- Kayikci, Y. (2018). Sustainability impact of digitization in logistics. *Procedia Manufacturing*, *21*, 782–789. <https://doi.org/10.1016/j.promfg.2018.02.184>
- Kembro, J., & Norrman, A. (2019). Exploring trends, implications and challenges for logistics information systems in omni-channels. *International Journal of Retail & Distribution Management*, *47*(4), 384–411. <https://doi.org/10.1108/IJRDM-07-2017-0141>
- Lee, Z. W., Chan, T. K., Chong, A. Y.-L., & Thadani, D. R. (2019). Customer engagement through omnichannel retailing: The effects of channel integration quality. *Industrial Marketing Management*, *77*, 90–101. <https://doi.org/10.1016/j.indmarman.2018.12.004>
- Li, J., Zeng, X., & Stevels, A. (2015). Ecodesign in Consumer Electronics: Past, Present, and Future. *Critical Reviews in Environmental Science and Technology*, *45*(8), 840–860. <https://doi.org/10.1080/10643389.2014.900245>
- Melacini, M., & Tappia, E. (2018). A Critical Comparison of Alternative Distribution Configurations in Omni-Channel Retailing in Terms of Cost and Greenhouse Gas Emissions. *Sustainability*, *10*(2), 307. <https://doi.org/10.3390/su10020307>
- Moher, D., Liberati, A., Tetzlaff, J., & Altman, D. G. (2009). Preferred reporting items for systematic reviews and meta-analyses: The PRISMA statement. *PLoS Medicine*, *6*(7), e1000097. <https://doi.org/10.1371/journal.pmed.1000097>

- Moraes, C., Carrigan, M., & Szmigin, I. (2012). The coherence of inconsistencies: Attitude–behaviour gaps and new consumption communities. *Journal of Marketing Management*, 28(1-2), 103–128. <https://doi.org/10.1080/0267257X.2011.615482>
- Muñoz-Villamizar, A., Velázquez-Martínez, J. C., Haro, P., Ferrer, A., & Mariño, R. (2021). The environmental impact of fast shipping ecommerce in inbound logistics operations: A case study in Mexico. *Journal of Cleaner Production*, 283, 125400. <https://doi.org/10.1016/j.jclepro.2020.125400>
- Nguyen, N., & Johnson, L. W. (2020). Consumer behaviour and environmental sustainability. *Journal of Consumer Behaviour*, 19(6), 539–541. <https://doi.org/10.1002/cb.1892>
- Olaf Roik (2023). HDE Online Monitor 2023. https://einzelhandel.de/images/attachments/article/2876/HDE_Online_Monitor_2023.pdf
- Page, M. J., McKenzie, J. E., Bossuyt, P. M., Boutron, I., Hoffmann, T. C., Mulrow, C. D., Shamseer, L., Tetzlaff, J. M., Akl, E. A., Brennan, S. E., Chou, R., Glanville, J., Grimshaw, J. M., Hróbjartsson, A., Lalu, M. M., Li, T., Loder, E. W., Mayo-Wilson, E., McDonald, S., . . . Moher, D. (2021). The PRISMA 2020 statement: An updated guideline for reporting systematic reviews. *BMJ*, 372, n71. <https://doi.org/10.1136/bmj.n71>
- Pan, S., Giannikas, V., Han, Y., Grover-Silva, E., & Qiao, B. (2017). Using customer-related data to enhance e-grocery home delivery. *Industrial Management & Data Systems*, 117(9), 1917–1933. <https://doi.org/10.1108/IMDS-10-2016-0432>
- Peng, Y., Liu, Y., & Ablanedo-Rosas, J. H. (2022). Store density in omnichannel implementation while considering the environmental impact of packaging materials. *Journal of Cleaner Production*, 371, 133668. <https://doi.org/10.1016/j.jclepro.2022.133668>

- Pourmohammadreza, N., Jokar, M. R. A., & van Woensel, T. (2025). Last-mile logistics with alternative delivery locations: A systematic literature review. *Results in Engineering*, 25, 104085. <https://doi.org/10.1016/j.rineng.2025.104085>
- Risberg, A., & Jafari, H. (2022). Last mile practices in e-commerce: framework development and empirical analysis of Swedish firms. *International Journal of Retail & Distribution Management*, 50(8/9), 942–961. <https://doi.org/10.1108/IJRDM-10-2021-0513>
- Sallnäs, U., & Björklund, M. (2020). Consumers' influence on the greening of distribution – exploring the communication between logistics service providers, e-tailers and consumers. *International Journal of Retail & Distribution Management*, 48(11), 1177–1193. <https://doi.org/10.1108/IJRDM-07-2019-0213>
- Sarinya L. Suttharatanagul, Norawat CHUTIVONGSE, Benjamard JONGMAHASANCHAI, & Ruedee LIMPAIROJ (2025). The MODERATING ROLE OF SOCIAL INFLUENCE ON BRAND IMAGE AND PURCHASE INTENTION FOR SUSTAINABLE PRODUCTS. *Procedia of Multidisciplinary Research*, 3(1), 10. <https://so09.tci-thaijo.org/index.php/PMR/article/view/5739>
- Shao, P., & Lasseben, H. (2021). Determinants of Consumers' Willingness to Participate in Fast Fashion Brands' Used Clothes Recycling Plans in an Omnichannel Retail Environment. *Journal of Theoretical and Applied Electronic Commerce Research*, 16(7), 3340–3355. <https://doi.org/10.3390/jtaer16070181>
- Siyal, S., Ahmed, M. J., Ahmad, R., Khan, B. S., & Xin, C. (2021). Factors Influencing Green Purchase Intention: Moderating Role of Green Brand Knowledge. *International Journal of Environmental Research and Public Health*, 18(20), 10762. <https://doi.org/10.3390/ijerph182010762>

- Sousa, P. R. de, Barbosa, M. W., Oliveira, L. K. de, Resende, P. T. V. de, Rodrigues, R. R., Moura, M. T., & Matoso, D. (2021). Challenges, Opportunities, and Lessons Learned: Sustainability in Brazilian Omnichannel Retail. *Sustainability*, *13*(2), 666.
<https://doi.org/10.3390/su13020666>
- Tajfel, H., & Turner, J. C. (1986). The Social Identity Theory of Intergroup Behavior. *Psychology of Intergroup Relation*, 7–24.
<https://christosaioannou.com/Tajfel%20and%20Turner%201986.pdf>
- Verhoef, P. C., Kannan, P. K., & Inman, J. J. (2015). From Multi-Channel Retailing to Omnichannel Retailing. *Journal of Retailing*, *91*(2), 174–181.
<https://doi.org/10.1016/j.jretai.2015.02.005>
- Vhatkar, M. S., Raut, R. D., Gokhale, R., Cheikhrouhou, N., & Akarte, M. (2024). A glimpse of the future sustainable digital omnichannel retailing emerges - A systematic literature review. *Journal of Cleaner Production*, *442*, 141111.
<https://doi.org/10.1016/j.jclepro.2024.141111>
- Xu, J., Lyu, G., Bai, Q., & Luo, Q. (2023). Robust pricing and inventory strategies for an omnichannel retailer under carbon tax and cap-and-offset regulations. *Computers & Industrial Engineering*, *185*, 109615. <https://doi.org/10.1016/j.cie.2023.109615>
- Zhuo, Z., Ren, Z., & Zhu, Z. (2023). *Attitude-Behavior Gap in Green Consumption Behavior: A Review*.

PUBLICATIONS**Accepted / In press**

Raether, J., Végvári, B., & Szente, V. (in press). Sustainable consumer behavior in omnichannel electronics retailing: Evidence from a pilot study. *Tér – Gazdaság – Ember: Journal of Region, Society and Economy*.

Raether, J., Osiako, P. O., & Szente, V. (in press). Sustainability challenges in omni-channel retailing: A systematic review. *Regional and Business Studies*.

Published

Osiako, P. O., Raether, J., & Szente, V. (2022). The influence of marketing communication channels on the motivations, consumption behaviour, and satisfaction of domestic tourists in Kenya. *Regional and Business Studies*, 14(1), 17–31. <https://doi.org/10.33568/rbs.3598>