



HUNGARIAN UNIVERSITY OF AGRICULTURE AND LIFE SCIENCES

Solar PV tree based on spherical configuration

PhD Dissertation

by

Mensour Saheb Malek Almadhhachi

Gödöllő

2024

Doctoral school

Denomination: Doctoral School of Mechanical Engineering

Science: Mechanical Engineering

Leader: Prof. Dr. Gábor Kalácska, DSc
Institute of Technology
Hungarian University of Agriculture and Life Science, Gödöllő,
Hungary

Supervisor: Prof. Dr. István Farkas, DSc
Institute of Technology
Hungarian University of Agriculture and Life Science, Gödöllő,
Hungary

Co-Supervisor: Dr. István Seres, PhD
Institute of Mathematics and Basic Science
Hungarian University of Agriculture and Life Science, Gödöllő,
Hungary

.....
Affirmation of supervisor

.....
Affirmation of head of school

CONTENTS

NOMENCLATURE AND ABBREVIATION	6
1. INTRODUCTION, OBJECTIVES	8
1.1. Introduction	8
1.2. Objectives.....	10
2. LITERATURE REVIEW.....	12
2.1. Concepts of solar tree.....	12
2.2. Components of the solar tree.....	12
2.2.1. <i>PV modules</i>	13
2.2.2. <i>Batteries</i>	14
2.2.3. <i>Inverters</i>	15
2.2.4. <i>Cables and connections</i>	15
2.2.5. <i>Frame structure</i>	15
2.3. Configuration of solar trees.....	15
2.3.1. <i>Multi-branch single stem</i>	16
2.3.2. <i>Fibonacci pattern solar tree</i>	16
2.3.3. <i>Spiralling phyllotaxy solar tree</i>	17
2.3.4. <i>Hemispherical dome solar tree</i>	18
2.3.5. <i>Three-dimensional geometric design</i>	18
2.3.6. <i>Ross Lovegrove solar tree</i>	19
2.3.7. <i>Simple solar tree</i>	20
2.3.8. <i>Super trees</i>	21
2.3.9. <i>Smart palm tree</i>	21
2.4. Parameters influencing solar tree performance.....	22
2.4.1. <i>Footprint</i>	22
2.4.2. <i>Solar tree design</i>	23
2.4.3. <i>Shadow loss</i>	24
2.4.4. <i>Solar tree structure and material</i>	25
2.4.5. <i>Efficiency</i>	26
2.4.6. <i>Maximum power tracking</i>	26
2.4.7. <i>Cost</i>	29
2.5. Solar tree commercialization.....	30
2.5.1. <i>Conventional PV and solar tree technologies</i>	31
2.5.2. <i>Comparison among commercial solar trees</i>	32

2.6. Summary of literature review	34
3. MATERIALS AND METHODS	35
3.1. Study location.....	35
3.2. Materials and instrumentations	36
3.2.1. <i>Monocrystalline PV module</i>	36
3.2.2. <i>Polycrystalline PV module</i>	37
3.2.3. <i>Thin film PV module</i>	37
3.2.4. <i>Pyranometer</i>	38
3.2.5. <i>Multimeter</i>	39
3.2.6. <i>Weather station</i>	39
3.2.7. <i>Datalogger</i>	39
3.3. PV configuration types.....	40
3.3.1. <i>Flat PV module</i>	40
3.3.2. <i>Solar tracker hemispherical PV module</i>	41
3.3.3. <i>Hemispherical PV module</i>	42
3.3.4. <i>Spherical PV module</i>	43
3.3.5. <i>Sunflower PV module</i>	43
3.4. Experimental procedure	44
3.4.1. <i>Testing the solar tracker hemispherical PV module</i>	44
3.4.1.1. The inclination angle of 45°	45
3.4.1.2. The inclination angle of zero-degree	46
3.4.2. <i>Testing the spherical and hemispherical PV module</i>	47
3.4.2.1. Single spherical shape.....	47
3.4.2.2. Three spherical shapes	47
3.4.2.3. Single hemispherical shape.....	48
3.4.2.4. Two hemispherical shapes	49
3.4.2.5. Three hemispherical shapes	50
3.4.3. <i>Testing the sunflower PV module</i>	51
3.5. Calculation methods.....	53
3.5.1. <i>Power calculation</i>	53
3.5.2. <i>Footprint calculation</i>	56
3.6. Temperature measurements	57
3.7. Uncertainty analysis	59
4. RESULTS	60
4.1. Solar tracker hemispherical PV module.....	60

4.1.1. Inclination angle of 45° for the flat and hemispherical PV modules.....	60
4.1.2. Analysis of the hemispherical and flat PV modules with horizontal position	62
4.2. Spherical and hemispherical PV module	65
4.2.1. Single spherical PV module	65
4.2.2. Three spherical PV modules	66
4.2.3. Single hemispherical PV module	68
4.2.4. Two hemispherical PV modules.....	69
4.2.5. Three hemispherical PV modules	70
4.3. Solar tree mode	71
4.3.1. The temperature of PV modules.....	71
4.3.1.1. The tilt angle of 45°	71
4.3.1.2. The tilt angle of 30°	73
4.3.1.3. The tilt angle of 20°	74
4.3.2. The power generation	76
4.3.2.1. The tilt angle of 45°	77
4.3.2.2. The tilt angle of 30°	78
4.3.2.3. The tilt angle of 20°	79
4.3.3. Positioning of PV modules for optimal solar tree design.....	80
4.3.4. The land footprint of solar PV tree vs. flat PV module.....	81
4.4. Land occupancy ration	81
4.5. Power/land occupancy ratio	82
4.6. New scientific results	83
5. CONCLUSION AND SUGGESTIONS	85
6. SUMMARY	86
7. ÖSSZEFOGLALÁS (SUMMARY IN HUNGARIAN).....	87
8. APPENDICES.....	88
A1: Bibliography.....	88
A2: Publications related to the dissertation.....	99
9. ACKNOWLEDGEMENT	101

NOMENCLATURE AND ABBREVIATION

A	PV module surface area (m^2)
A_{alt}	Altitude of the PV module (km)
A_c	Projection circle area (m^2)
g	Acceleration due to gravity (m s^{-2})
G	Global radiation (W m^{-2})
G_d	Diffuse radiation (W m^{-2})
H	Height (m)
I_0	Extra-terrestrial radiation (W m^{-2})
I_{max}	Maximum working current (A)
I_{sc}	Short circuit current (A)
L	PV module length (mm)
n	Number of PV modules
P_m	Maximum power (W)
T	PV module thickness (mm)
t	Temperature ($^{\circ}\text{C}$)
V_{max}	Maximum working voltage (V)
V_{oc}	Open circuit voltage (V)
V_w	Wind velocity (m s^{-1})
W	PV module width (mm)
3D	Three dimensions
<i>Greek symbols</i>	
α	PV module tilt angle ($^{\circ}$)
δ	Declination angle ($^{\circ}$)
η	Efficiency
θ_z	Zenith angle ($^{\circ}$)
γ	Azimuth angle ($^{\circ}$)
τ_b	Atmospheric transmissivity
w	Uncertainty
Φ	Latitude ($^{\circ}$)
ω	Hour angle ($^{\circ}$)

<i>Abbreviations</i>	
<i>AC</i>	Alternating current
<i>DC</i>	Direct current
<i>FPST</i>	Fibonacci pattern solar tree
<i>HDST</i>	Spiralling phyllotaxy solar tree
<i>HDST</i>	Hemispherical dome solar tree
<i>LCD</i>	Liquid-crystal display
<i>LED</i>	Light-emitting diode
<i>MBSS</i>	Multi-branch single stem
<i>MPP</i>	Maximum power point
<i>MPPT</i>	Maximum power point tracking
<i>PV</i>	Photovoltaic
<i>RLST</i>	Ross Lovegrove solar tree
<i>TDGD</i>	Three-dimension geometric design
<i>TPVD</i>	Three PV design
<i>NTC</i>	Negative temperature coefficient
<i>DRM</i>	Denkovi relay manager (Software)

1. INTRODUCTION, OBJECTIVES

This chapter presents the background and the importance of the study as well as the objectives of the research.

1.1. Introduction

The quest for sustainable and clean energy sources has become one of the greatest challenges recently because of the rapid loss of conventional fossil fuels, climate change, global warming, and the ever-rising energy demand (Hyder et al., 2018b; Almadhhachi et al., 2020). Renewable energy is relatively cheaper, more affordable, and more environmentally friendly than fossil fuel oil (Almadhhachi et al., 2020). Renewable energy is commonly defined as energy from sunshine, wind, rain, oceans, waves, and geothermal heat, continuously replenished on a human time scale (Kim and Kim, 2015; Muminovic et al., 2013).

Renewable energy markets have been grown worldwide steadily due to strengthened international legislation, as recommended in the convention on climate change (Bantikatla et al., 2019). Moreover, many countries have invested massively in the renewable energy field, and this phenomenon is attributed to two significant factors (Al-Rousan et al., 2021; Nwaigwe et al., 2019). First, initial attempts to establish renewable energy sources have concentrated on global environmental issues; however, in the last few years, each country has attempted to enhance their energy stability and achieve sustainable economic development through renewable energy (Kim and Kim, 2015). Second, to reduce greenhouse gas emissions and global warming, which could lead otherwise to temperature rising, seawater rising level, and risks of heatwaves (Al-Yasiri et al., 2022; Al-Yasiri and Géczi, 2021). The energy intercepted by the earth from the sun is approximately 1.5×10^{18} kWh/year, which is several times higher than the actual energy consumption rate (Patil, 2018).

There are two main types of technology to accumulate solar energy: First, solar thermal is a viable option for generating energy, processing chemicals, and providing space heating and cooling for buildings; food, non-metallic, textile, chemical, and even business-related industries can all benefit from it. Second, photovoltaics (PV) is widely used to power lights, pumps, engines, fans, refrigerators, and water heaters in the telecommunications, agricultural, water desalination, and construction industries (Avdic et al., 2013; Mekhilef et al., 2011). One of the easiest ways to harvest solar power is by employing PV technology (Ishaq and Ibrahim, 2013; Parida et al., 2011). Photovoltaic (PV) systems, which convert the sun's useful power to electricity and then convert from DC to AC, drive this transformation (Lingayat et al., 2020; Nwaigwe et al., 2019).

Fig. 1.1 shows the rapid development and growth of solar PV technology worldwide, which gives researchers a motivation to make a greater effort to overcome obstacles, study challenges, and find solutions to obtain the largest possible amount of energy with relatively higher efficiency. A PV system transforms photons from the sun into electricity, typically built with silicon wafers, in a process known as photoelectric conversion. Solar modules must be positioned so that the sun's light is focused on its surface to generate more electricity from the sun (Almadhhachi et al., 2022a). This can be accomplished by continuously tracking the sun. On the other hand, tracking systems with numerous moving parts have significant drawbacks related to instability of structural design problems, particularly in lousy weather conditions, lower system life, and high initial or maintenance costs (Hartner et al., 2015).

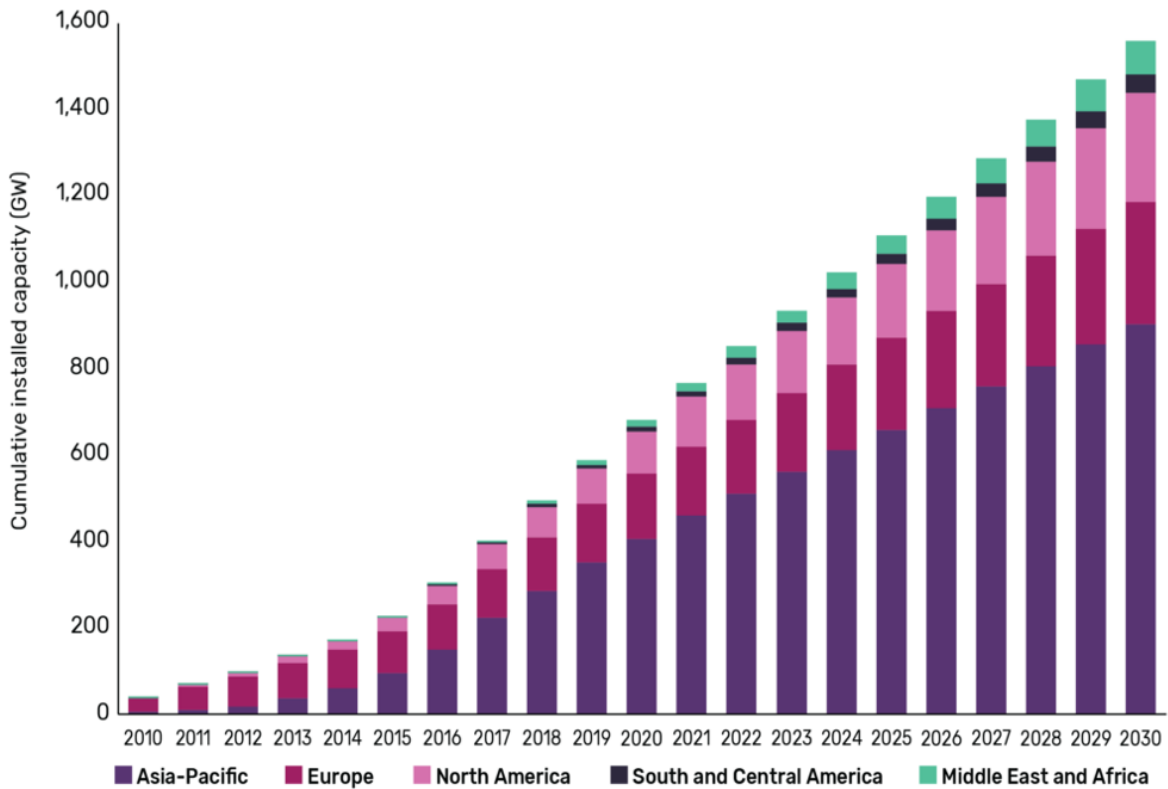

Fig. 1.1. Global solar photovoltaic capacity expected (2010-2030) (Ldata, 2019)

Solar modules with fixed orientation or a few seasonal adjustments are ideal for acquiring an excellent yearly average solar irradiation. Shukla et al. (2017) covered the issues, regulations, and suggestions for alternative energy resources in South Asia in their research. Global plans for a healthy and sustainable future have prioritised renewable energy-based growth (Lu et al., 2020). In order to increase cell conversion efficiency, lower manufacturing costs, and use less energy during the process, the manufacturing of PV cells is the subject of intensive study. Jean et al. (2015) analysed the cost, material complexity, and efficiency of solar PV technology in the future. Environmental concerns, helpful governmental initiatives, and the unpredictability of grid supply have all contributed to PV-based electricity systems' recent and rapid global development (Wen et al., 2020). The usage of solar photovoltaic technology in the off-grid countryside, island countries, and domestic settings is quite advantageous.

Grid-connected PV systems are growing as well (Ayora et al., 2023), and power infrastructures are being modified to handle the PV systems' sporadic energy delivery (Bakhshi and Sadeh, 2018). The area needs for PV systems must be reduced to improve their implementation because the land is necessary for parking, transportation, manufacturing, and housing despite all the benefits of solar energy. By adding PV modules to buildings and homes' roofs as well as their facades and walls, integrated buildings with PV systems may reduce the amount of land footprint needed for solar PV systems (D'Agostino et al., 2022). Shukla et al. (2016) discussed a lifetime cost study of installing and maintaining a rooftop solar PV system, which has also been completed. Additionally, the PV generation cost and environmental benefit are highlighted.

PV modules can be manufactured in many different technologies, and also the varied PV module types have different spectrum reactions, temperature coefficients, voltage, and current values, as well as different reactions to environmental elements such as radiation, temperature, wind speed, and different efficiencies between 11% -21% (Elibol et al., 2017; Jordehi, 2016). The temperature affects the solar PV module efficiency inversely after 25 °C (Alshawaf et al., 2020). It is possible that an efficient solar PV plant with a high number of small-sized polycrystalline modules might be more energy efficient than a system with larger-sized glass modules (Dhaundiyal and Atsu, 2021). A parabolic bifacial photovoltaic is one of the methods to reduce the temperature and keep the efficiency of the solar cells (El Majid et al., 2019). The direction of the PV module plays a vital role in PV technology efficiency. To harvest the most solar power, the solar module should be perpendicular to the direct incident sunlight (Abdollahpour et al., 2018).

Several techniques have been adopted to reach this goal. Among others, the solar tracking system has been applied to improve the overall system efficiency, tracking the sun rays using a special controlled mechanism (Hammoumi et al., 2018). It has been reported that up to 37.3% enhancement in the PV system could be achieved with a solar tracking system (Alktranee et al., 2020). Due to the presence of spinning components, PV systems' integrated tracking method has more complicated control and design mechanisms (Awasthi et al., 2020). PV technology lacks aesthetics due to the black or blue colour of the PV module; on the other hand, it needs a large flat area to install the solar system (Pemula, 2017). Solar trees combine an integrative process between technical effort and modern technology to create an advanced form that produces electricity from solar energy, and the amount of shade provided by trees can have a considerable impact on human thermal comfort (de Abreu-Harbach et al., 2015).

Researchers and inventors have been racing to create new artistic forms for several years to achieve utility from solar cell technology (Cao et al., 2014; Torgal, 2016). Due to its direct conversion of sunlight into electricity, ease of use, and clean energy generation, solar tree systems are seen as a viable source of energy (Hyder et al., 2018a; M. Kumar et al., 2021). When compared to flat solar PV, solar tree structures employ 1% of the land surface and boost efficiency by 10% to 15% by providing variable height and unique design (Gangwar et al., 2021; Gupta, 2021). Solar tree designs are unique, and they're made to help people in a variety of urban and natural settings; they can produce more than 10% electrical power compared with conventional PV systems (Baci et al., 2020; Rajaei and Jalali, 2022).

1.2. Objectives

In accordance with existing literature and contemporary research, photovoltaic technology confronts several constraints, including the necessity for expansive ground space, the substantial initial costs involved in project establishment, aesthetic deficiencies, diminished system efficiency, susceptibility to weather conditions, and sensitivity to sunlight inclination angles.

Researchers have diligently endeavoured to ameliorate these challenges, often resorting to the incorporation or augmentation of materials and mechanisms to enhance the functionality of photovoltaic systems. Notably, a relatively limited number of studies have focused on

modifying the external appearance of photovoltaic systems. This study introduces an innovative integration of solar tree technology, which endeavours to mitigate various limitations while concurrently altering the external morphology of solar modules, adopting spherical and hemispherical configurations. This design innovation seeks to address and alleviate specific challenges inherent in solar cell systems through straightforward yet effective solutions.

The detailed research objectives are articulated as follows and will be pursued through practical experiments:

- Examining the use of spherical shapes in solar modules to reduce the ecological footprint of solar energy installations.
- Examining hemispherical solar module configurations as an alternative to costly solar tracking systems, aiming to address the challenge of the sun's changing position throughout the day.
- Introducing a novel solar tree design, drawing inspiration from natural trees, with the intention of enhancing aesthetic elements within urban landscapes.
- Constructing a model of the most efficacious existing solar tree designs for the purpose of contrasting and evaluating the novel tree configuration, aiming to discern the distinctive strengths and attributes inherent in the innovative shape.
- Investigate the impact of shadows on the land created by solar tree structures and propose suitable applications for this phenomenon.

The structure of the thesis is delineated as follows. In Chapter 1, motivations for utilizing solar PV systems are expounded upon, alongside elucidating the study's primary objectives. Chapter 2, the literature review, encompasses an examination of pertinent research papers related to the thesis topic. This review aims to identify and elucidate research gaps within the existing body of literature. Chapter 3 provides an in-depth exposition of the experimental setup involving spherical and hemispherical photovoltaic modules, as well as the solar tree. This chapter further outlines the equipment employed for data collection purposes. In Chapter 4, the experimental outcomes derived from new PV configuration layouts are meticulously presented. Figures illustrating the data obtained from multiple trial days and comprehensive explanations are included. This chapter encompasses the affirmation of thesis statements and introduces novel scientific findings. Chapter 5 subsequently consolidates the primary conclusions and offers recommendations while also outlining potential avenues for future research.

2. LITERATURE REVIEW

This chapter provides a full overview of various types of solar trees and their applications, including fundamental solar tree concepts and solar tree classification, and highlights their performance in terms of influence design parameters commercialization. Recent advancements in this field have been thoroughly investigated, and a research gap has been identified.

2.1. Concepts of solar tree

Solar trees are a decorative (or antiquated) means of producing renewable electricity; most often, solar trees embody a steel structure (Berny et al., 2015). The modules are arranged in layers or in symmetrical or random shapes to absorb the enormous amount of solar PV energy to generate electricity. Given that PV modules are set at different angles, a solar PV tree can capture sunlight throughout the day regardless of the sun's position. One of the most essential definitions of solar trees is to enhance the total surface area of sunlight absorption through a three-dimensional (3D) structure compared with the traditional PV modules of solar cells (Bernardi et al., 2012). The concept of a "solar PV tree" is an advanced blend of modern technology and art to form a solar PV sculpture (Hyder et al., 2018c; Renugadevi, 2017). This idea uses solar energy and adds aesthetics to cities with an environmentally friendly technological nature (Jain and Verma, 2019). Sheds under solar trees can be used as public seats in gardens and parks or as good areas to benefit from agriculture. Many types of solar trees are designed based on optimal energy feasibility. Solar trees generate renewable energy and electricity (Muminovic et al., 2013; Shanmukhi et al., 2019).

The initiation of the idea of solar trees boosts the public understanding of solar PV technology by making it aesthetically appealing. The goals of the concept of a solar tree are:

- Increase civilian awareness of the use of renewable energy and solar energy.
- Increasing the number of artificial trees in residential cities affects civilians' comfort.
- Increase the efficiency of the solar system as possible.
- Add aesthetics to municipalities to build environmentally friendly forms.
- Create a new structure for the surrounding fences for service and entertainment projects, such as parks and gardens.

2.2. Components of the solar tree

Fig. 2.1, depicts the components and overall arrangement of a solar tree. Solar trees are solar-powered structures that mimic the appearance of a real tree (Balaji et al., 2020). The state-of-the-art consists of a steel frame with solar modules installed on top to capture sunlight and turn it into usable electricity. Solar trees are used to charge cell phones, computers, small appliances, and streetlights attached or built into the structure (Duque et al., 2018). They are intended to solve the large land requirements of solar modules, raise public consciousness about green and clean energies, and improve the performance of solar modules in urban areas.

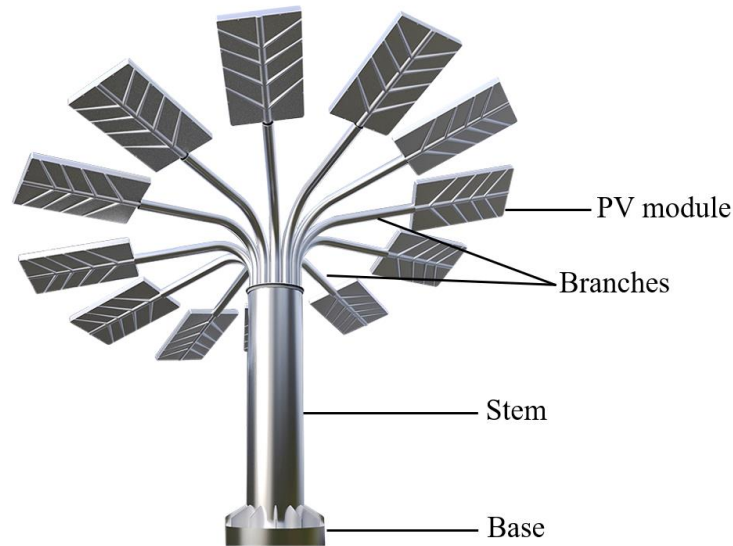

Fig. 2.1. Layout of hybrid solar tree

2.2.1. PV modules

Solar PV modules are an essential part of solar trees because they convert solar energy into electric current energy. PV cells are energy-harvesting technologies that transform solar power into convenient energy through PV effects (Awan et al., 2020). These solar cells consist of two distinct types of semiconductors, as shown in Fig. 2.2.

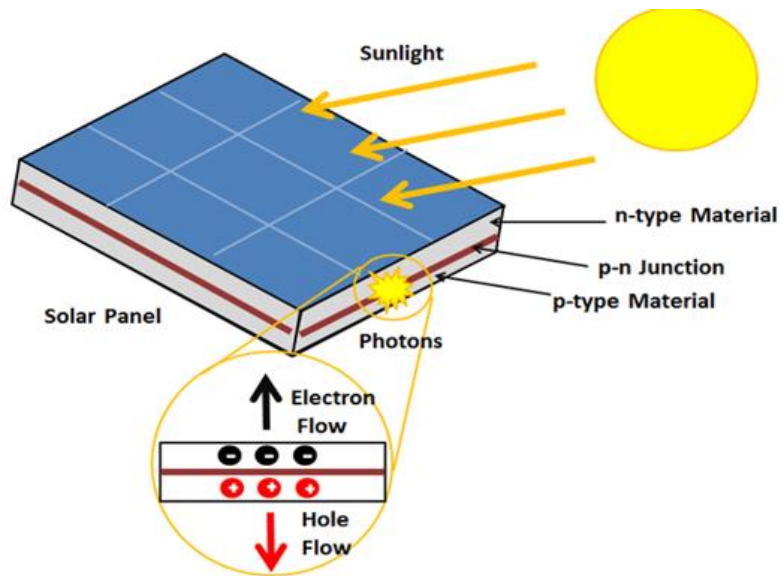

Fig. 2.2. Work mechanism of PVs

There are many types of solar cells, and each type has its advantages, efficiency, cost, and applications. The overall performance of silicon solar cells for domestic and industrial use is 92% of total worldwide silicon solar modules (Kim et al., 2021). Over the past decade and a half, there has been a noteworthy advancement in this technology, evidenced by the attainment of a laboratory efficiency rate of 46% (Dimroth, 2014). In contrast, silicon-based solar cells maintain a predominant position within the photovoltaic market at the present moment (Kumari et al., 2022; Ramanujam et al., 2020). the practical efficiency of modules available in the

market currently stands at 29% (Mathews et al., 2019). Presently, commercially deployed silicon-based solar cells exhibit an efficiency proximate to 25%, with silicon-based tandem solar cells achieving efficiencies near or surpassing the 30% threshold. These silicon solar cells demonstrate robust longevity, maintaining reliable performance for approximately three decades, irrespective of prevailing operational conditions encompassing varying moisture and oxygen levels, as well as ultraviolet light exposure. In contrast, the emergent genre of flexible solar cells distinguishes itself by fulfilling the exigencies of portability and wearability, attributes that are increasingly sought after in contemporary applications. (Kim et al., 2021). These modules exhibit categorization into multiple types, each distinguished by distinct attributes and merits encompassing efficiency, cost-effectiveness, longevity, flexibility, lifespan, and chromatic variations. The trichotomy of predominant solar cell classifications comprises monocrystalline (mono), polycrystalline (poly), and thin-film (Almadhhachi et al., 2022b). The efficiency of flexible modules can reach 24% (Asaduzzaman et al., 2016; Zomer et al., 2020). Mono, poly, and flexible solar cells are resistant to weather conditions such as sunlight, heat, and wind, and have a lifespan of up to 20 years (Aghaei et al., 2022). “Vertically integrated” solar module producers are well known; it implies that one business supplies and manufactures all the essential elements, including silicone ingots and wafers for solar cells. However, numerous module makers assemble solar modules, including cells, polymer back sheets, and EVA enclosures, by utilizing external sources. These producers can choose the components but cannot always control product quality. Thus, they should make sure that they choose the best possible suppliers (Jincy et al., 2015). Fig. 2.3, shows the six primary components of a solar module.

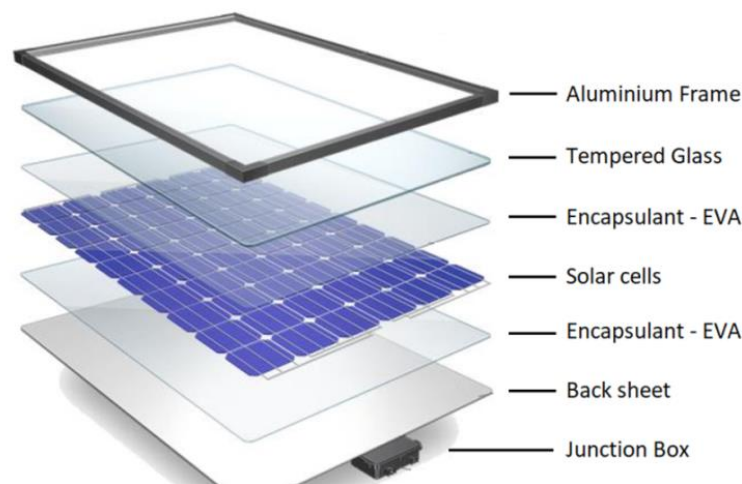

Fig. 2.3. Main components of a solar module (Svarc, 2020)

2.2.2. Batteries

Batteries are one of the most costly elements (Hassan et al., 2021) and an essential part of solar energy systems. They are among the oldest technologies that have accompanied the discovery of electricity and continue to develop in terms of materials used in their manufacture, shape, design, and amount of energy capable of storing it. Deep-cycle batteries have been used for green and clean energy applications worldwide for decades. The back-to-the-box acid, lithium-ion batteries, lithium polymer batteries, and nickel–cadmium batteries are some of the most

commonly used batteries in PV applications. Lithium-ion batteries are comparable to energy storage costs (Prakash et al., 2020; Zubi et al., 2020).

2.2.3. Inverters

Smart inverters are power electronic instruments with advanced features in external software that control the inverter's behaviour as connected to the grid (Rangarajan et al., 2019). Inverters aim to convert the DC voltage produced by the solar modules into the AC voltage's grid frequency. The most critical aspect of an inverter is its conversion quality. Current devices can run via an inverter with a performance of about 98% (Hyder et al., 2018c). Other essential activities of the inverter are power optimization (i.e., maximum power point tracking (MPPT)), control of the PV plant's energy yield, and protection of the plant by disconnecting it from the grid in the event of faults. Each panel receives a different irradiance in a solar tree to have different I-V and PV curves. Thus, the voltage fixed by the inverter will result in significant conversion losses. A battery can store energy and provide constant power to an inverter to prevent this problem.

2.2.4. Cables and connections

Atmospheric conditions such as precipitation, snow formation, solar irradiation, and high temperatures are subject to PV modules. Cables of outstanding mechanical strength are necessary to provide stable connections between the modules for use in environments with high mechanical stress, dry and wet weather, elevated temperature conditions, and high solar insolation. Losses due to connections and cables in small solar PV systems can be represented by 1% (Ekici and Kopru, 2017).

2.2.5. Frame structure

The metal structure is subject to the innovator, how it can branch or what height it reaches, and the trees' dimensions. All these details are subject to the innovator of the solar tree. Solar trees differ from one design to another and according to the applications. The external structure must be strong enough to preserve the tree under different weather conditions, such as wind load, which plays a vital role in the design calculations of the tree structure. In this regard, solar trees may overturn in high winds due to the great strength of the tree, not to mention that the aesthetics of the external structure should not be ignored (Oluwafemi et al., 2019). The type of metal structure is one of the costly parts. Studies have used reinforced plastic to reduce the costs of constructing the solar tree structure (Shanmukhi et al., 2019). The design is optimized to minimize the weight and maximize the power generation on different components of the solar tree (i.e., trunk, base plates, middle flats, stalks, and gussets) (Srisai and Harnsoongnoen, 2019). The body weight was significantly lowered by 40% by applying tree structure optimization. By leveraging genetic algorithms, a 20% structural mass reduction is achieved in a confined space (Dey and Pesala, 2020).

2.3. Configuration of solar trees

The types of designed trees are displayed spiralling phyllotaxy solar tree (SPST), Fibonacci pattern solar tree (FPST), single trunk with branches, and three-axis symmetric design.

Modules on a natural tree are typical shapes, structures, and patterns of solar trees. Researchers and designers have struggled to obtain beautiful engineering art forms since 1997, and the technology is promising (Liu et al., 2015; Tooby and Cosmides, 2001). Some companies produce various types of solar trees, which proves that solar trees have a commercial market in various parts of the world. Most of the trees mentioned in the research and markets are included in this study.

2.3.1. Multi-branch single stem

Multi-branch single stem (MBSS) is a humble structure consisting of a long column; this column looks like a tree stem and branches emerging at different heights, as shown in Fig 2.4, carrying solar modules at different surface angles and orientations according to the areas in which these trees are applied (Dey and Pesala, 2020). MBSS is characterized by the design simplicity that is easy to develop, but it is considered one of the least efficient designs in capturing solar radiation throughout the daytime due to the orientation of the solar module with different lengths of tree branches (Hyder et al., 2018c).



Fig. 2.4. MBSS used for powering fuel station (Budapest, Hungary)

2.3.2. Fibonacci pattern solar tree

Fibonacci pattern solar tree (FPST) is the most popular solar tree nowadays, which captures sunlight with relatively high efficiency, as shown in Fig 2.5. This pattern helps direct the tree's leaves toward the sun to ensure that the most energy is absorbed (Singh et al., 2019). One of this tree's essential features is that it is borrowed from nature, as some likened it to an oak tree. It is considered a source of energy with a relatively constant amount (Aiden, 2011). One of these trees' determinants is the expensive seat structure that cannot be invested in large energy projects (Hyder et al., 2018c). FPST produces more energy than conventional PV modules (Gawad, 2021). In comparison to conventional solar panels, the 3/8 phyllotaxy-based solar tree provides 54% (approximate) more efficiency and 43% (approximate) more efficiency than the 2/5 phyllotaxy-based solar tree (Gangwar et al., 2021).



(a)



(b)

Fig. 2.5. FPST for low-scale electricity generation
(a) in India (Singh et al., 2019), (b) in USA (Aiden, 2011)

2.3.3. Spiralling phyllotaxy solar tree

Spiralling phyllotaxy solar tree (SPST) is innovative from natural plants is the most widespread and forms a large complex umbrella, which helps them capture sunlight in an extensive and highly efficient manner (Gangwar et al., 2019b). The productivity of these solar trees is high and closely mimics nature (Kumar et al., 2019). As shown in Fig. 2.6. (SPST) is one of the trees that consumes considerable space for its leaves, is extremely expensive due to its iron structure, and is challenging to manufacture (Deep et al., 2020; Gangwar et al., 2019a).



Fig. 2.6. SPST in Millennium square (Bristol, England) (Hjälms, 2015)

2.3.4. Hemispherical dome solar tree

A hemispherical dome solar tree (HDST) is a distinctive design that covers daylight hours to capture the sun's lights with the best efficiency. It consists of modules that form a semi-spherical dome, as shown in Fig. 2.7. It is directed toward the sun to cover the sun's path from morning to evening (Verma and Mazumder, 2014).

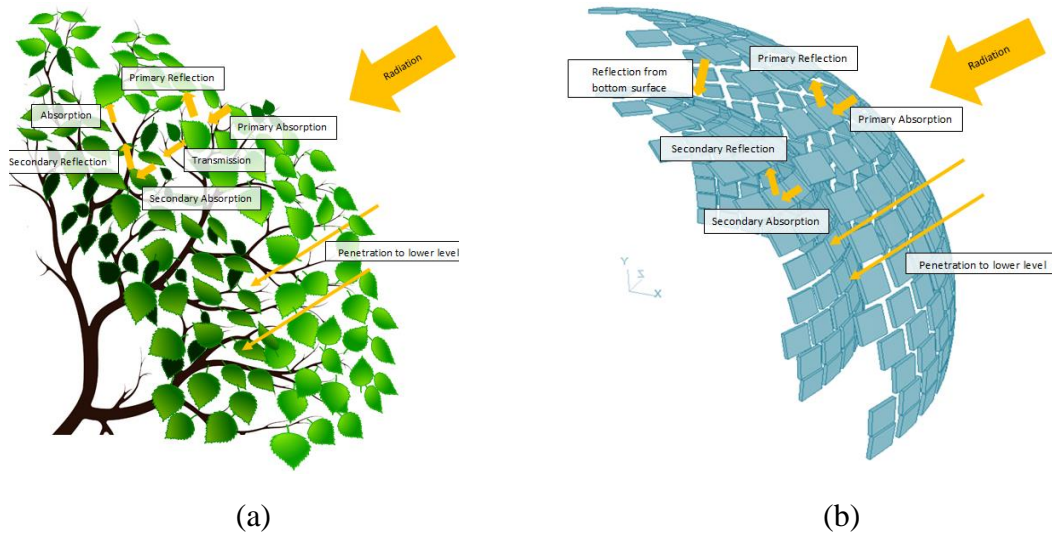

Fig. 2.7. HDST configuration (Verma and Mazumder, 2014)
 (a) Tree shape, (b) Simulated shape

2.3.5. Three-dimensional geometric design

A three-dimensional geometric design (TDGD) can be built using any 3D shape. The type of design consists of a leg, as shown in Fig. 2.8. At the top of the summit, a solar module is directed at a certain angle. Solar modules are distributed on the branches symmetrically and on both sides within specific inclination angles to enhance the capture of sunlight. It consists of three axes to form a 3D body, hence its name. It also takes less space for its papers. Its cost is relatively lower due to the ergonomic and minimalist design inside (Kumar et al., 2020a).



Fig. 2.8. Photo of TDGD

Fig. 2.9 shows that 3D shapes have proven higher efficiency than the average modules in harvesting sunlight and generating electricity significantly during the summer. These ratios may be higher in the winter season. This type provides large land areas, which is a valuable feature in cities (Bernardi et al., 2012).

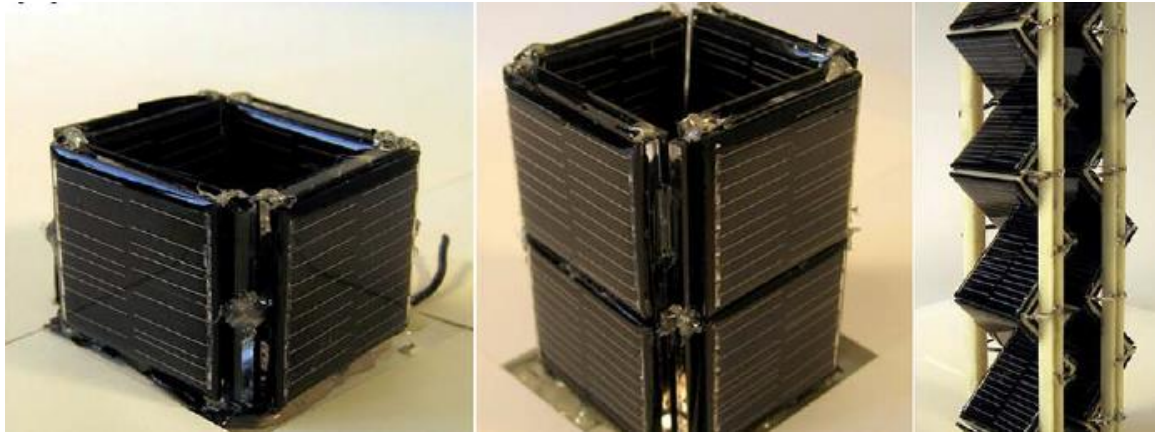

(a)

(b)

(c)

Fig. 2.9. Three samples of TDGD
(a) Single cube, (b) Double cube, (c) Three-dimensional body

2.3.6. Ross Lovegrove solar tree

Ross Lovegrove solar tree (RLST) comprises beautiful architectural designs or industrial art consisting of PV with curves in circular groups, which capture sunlight and have a height of 5.5 m, 40-mm grass stems, 1 LED with approximately 1 W and protected by a diffuser screen, and 10 poles (76 mm in diameter) that support the body heads Fig. 2.10. The 10 headers, which include the PV cells at the top and support poles with a diameter of 76 mm (Fairs, 2007). RLST also has 20 energy LED lights powered by 500 mA and have a neutral white temperature, and at the bottom of the 4 of them is an aluminium spoiler (Bingham, 2012).



Fig. 2.10. Photo of RLST (Milan)

2.3.7. Simple solar tree

This type of solar tree is one of the most widespread types. It is similar to solar module surface systems, except that these modules are installed on steel structures and at an appropriate height and a suitable slope to capture sunlight more efficiently, as shown in Fig. 2.11.



Fig. 2.11. Simple solar tree (Aurangabad, India) (IndiaMART, 2019)

It is considered one of the most effortless engineering designs. It is always inhomogeneous, symmetrical, and perpendicular to sunlight to ensure that an enormous amount of energy is absorbed (Javaid, 2020).

The world's largest solar tree is shown in Fig. 2.12. It was built in India and produced roughly 11,500 W of electricity. It was developed by the Central Mechanical Engineering Research Institute in 2020; it has 35 solar PV modules with 330 W for each module (NAIR, 2020).



Fig. 2.12. Largest solar tree installed in the world (India) (NAIR, 2020)

2.3.8. *Super trees*

The gardening project in Gardens by the Bay looks like something out of science fiction or an image of future cities. Nevertheless, it is an actual Singapore landscaping project, with tree heights ranging from 25 m to 50 m, as shown in Fig. 2.13. The value of this sophisticated horticultural project is approximately US \$1 billion (Sheppard, 2013). Engineers have created ultra-modern designs that mimic actual tree structures and ecological functions through their environmentally friendly features. PV technology has been incorporated into its illusions to capture sunlight to produce electrical energy while illuminating at night (Prize et al., 2014). This project includes 18 gigantic trees that serve as vertical gardens, 11 of which have been integrated with PV cells to generate electrical energy; thus, it forms an industrial mechanical forest that represents a distinct tourist destination that displays natural plants in addition to environmentally friendly industrial plants (Perry, 2019). The tree consists of a steel trunk fixed with reinforced concrete on the ground. The planting modules are installed along the trunk for planting plants, and vertical gardens are formed; the end of the trunk is in the form of an upside downslope, which is 50 m high (Solaripedia, 2014).



Fig. 2.13. Super tree (Singapore)

2.3.9. *Smart palm tree*

The new city-sponsored convenience for visitors and beachgoers is a 6 m tall solar-powered tower shaped like a palm tree. It will be a unique structure made with 3D printing technology Fig. 2.14, and it will be the largest of its type outdoors. Smart palms are powered by monocrystalline solar modules that provide up to 21% efficiency and generate sufficient power for daytime and nighttime functionality (O’Keefe, 2015). Smart palms are designed to serve as a functional public art that complements Dubai’s iconic architecture and scenic beaches.



Fig. 2.14. Layout of smart palm tree (Dubai, UAE) (O’Keefe, 2015)

2.4. Parameters influencing solar tree performance

The essential parameters that identify or distinguish solar trees according to previous studies are presented in this section.

2.4.1. Footprint

One of the main disadvantages of the solar PV system is that it occupies large areas of land (Deepak M. Patil, 2018; Khare et al., 2023). In comparison, the improved MBSS requires only 1% of the land for the same energy produced from sunlight compared with surface PV systems (Prasad et al., 2018). FPST is one of the best facilities that reduce the utilized land area compared with the modules because it covers only 1% of the land area for the same productive capacity (Singh et al., 2019). TDGD is becoming more common because it minimizes land use and provides various complimentary services to cover maintenance costs (Kumar et al., 2020b). Fig. 2.15, shows the relationship between land areas needed for the PV systems and the power generated, in which the solar tree produces more power for the same area. In a simulated study, Vyas et al. (2022) compared a 22.4 kW sunflower solar tree with a 22.4 kW conventional PV system, and the land footprint was saved by 92%.

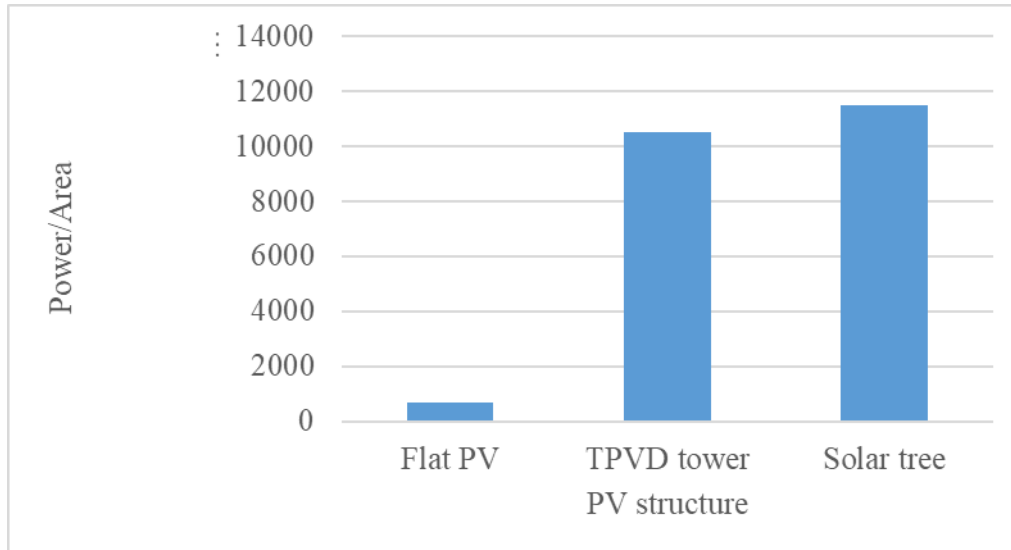

Fig. 2.15. Relationship between area and production power for PV structures (Bernardi et al., 2012; Javaid, 2020)

2.4.2. Solar tree design

Solar trees, characterized by their diverse shapes and dimensions, offer a versatile array of designs, ranging from regular geometric configurations (Hirani, 2020; NAIR, 2020; O’Keefe, 2015) to symmetric arrangements (Chitra et al., 2019; Prasad et al., 2018) and even more unpredictable random formations (Almadhhachi et al., 2022a; Shanmukhi et al., 2019). Furthering the spectrum of innovation, mathematical functions are employed to dictate the structure of solar trees under similar irradiated conditions (Singh et al., 2019). One intriguing finding in this field is the comparative power generation performance of different phyllotaxy patterns. For instance, a solar tree model adopting a 3/8 phyllotaxy pattern has been observed to outperform models based on a 2/5 phyllotaxy pattern and conventionally mounted solar modules (Gangwar et al., 2019a). This observation underscores the importance of carefully considering the direct normal irradiance (DNI) and diffuse horizontal irradiance (DHI) (Duffie et al., 1994) in the optimization of solar tree design, as articulated in Eq. 2.1:

$$GHI = DHI + DNI \cos(\alpha). \quad (2.1)$$

The nuanced exploration of these irradiance parameters becomes imperative in determining the optimum configuration for solar trees. This exploration is not merely a theoretical exercise but rather a practical necessity, as it directly influences the efficiency and overall performance of solar tree structures. By delving into various patterns and configurations grounded in both empirical experimentation and mathematical principles, researchers strive to unlock the full potential of solar trees in harnessing solar energy. This multifaceted approach contributes not only to advancing the fundamental understanding of solar tree dynamics but also to informing the design considerations critical for their effective deployment in diverse environmental contexts. Thus, the comprehensive analysis of solar tree design factors, as guided by equations such as 2.1, underscores the commitment to refining and optimizing these innovative structures to achieve sustainable and efficient solar energy integration.

In the realm of Tree-Photovoltaic Device (TDGD) exploration, a nuanced investigation has been undertaken, wherein three distinctive shapes have been meticulously modelled and subjected to simulation analyses. This methodical inquiry has provided valuable insights into the unique features inherent in each design, contributing to a comprehensive understanding of their respective energy dynamics. Notably, the observed increases in total energy output for a cube, tall cube, and tower stand out as 1.3–1.8, 3.5–5, and 2–20 times, respectively, when compared to conventional flat PV systems (Bernardi et al., 2012). This quantitative assessment illuminates the potential performance enhancements achievable through innovative TDGD configurations.

Moreover, a concerted effort to refine the structural integrity of TDGD has been pursued, with researchers leveraging the computational power of the MATLAB program to conduct simulations. The outcomes of these simulations have been particularly promising, revealing a significant 40% reduction in the original weight of the TDGD structure (Shanmukhi et al., 2019). What makes this achievement noteworthy is that it has been accomplished without compromising the tree's energy production capabilities. This dual focus on weight reduction and energy preservation exemplifies a synergistic approach, where advancements in structural efficiency align seamlessly with the overarching goal of enhancing energy harvesting systems.

The utilization of MATLAB as a simulation platform highlights the integration of advanced computational tools in optimizing TDGD structures. This approach not only streamlines the design refinement process but also facilitates a more sustainable and resource-efficient deployment of TDGD in practical applications. As the research community continues to unravel the intricacies of TDGD through simulations and structural improvements, these findings contribute not only to the theoretical knowledge base but also pave the way for more robust and efficient solar energy solutions. The intersection of design innovation, simulation technology, and structural optimization in TDGD research underscores a holistic approach towards advancing sustainable energy technologies.

2.4.3. Shadow loss

The solar tree, characterized by its layered arrangement of solar modules, confronts the challenge of inter-layer shading, resulting in decreased overall efficiency. This issue has spurred the exploration of innovative designs by designers and researchers seeking to ameliorate or eliminate mutual shading between modules and branches. The introduction of the Fractal Pattern Solar Tree (FPST) design pattern has proven instrumental in overcoming these challenges. Allowing the tree leaves to operate independently, the FPST mitigates energy production interference and demonstrates resilience against adverse weather conditions, such as snow (Rawat et al., 2017). The solar tree's architectural design is meticulously crafted to optimize sunlight capture, thereby minimizing shaded areas and rendering it a viable solution for deployment in agricultural contexts. Its potential to replace diesel-powered pumps and electronic tractors in such settings reflects a transformative impact on sustainable agricultural practices (Javaid, 2020).

Moreover, advancements in optimization techniques, such as the application of genetic algorithms, have played a pivotal role in refining the spatial arrangement of solar modules

within the Multilayered Branch Solar System (MBSS). This optimization not only addresses shade losses but also maximizes land utilization. The deliberate reduction in branch length within the solar tree not only contributes to a decrease in structural costs but also ensures an optimal balance between form and function. Impressively, the solar tree boasts a mere 0.17% annual decay loss and occupies a minimal natural footprint area of 1.67, affirming its efficiency and sustainability credentials (Dey and Pesala, 2020). The multifaceted contributions of these design elements underscore the solar tree's potential as a transformative solution in the realm of solar energy harvesting, particularly in agricultural and environmentally conscious applications.

2.4.4. Solar tree structure and material

Within the architectural realm, a fervent pursuit of creative solutions has been observed, particularly in the context of addressing challenges related to sustainable energy. The innovative spirit driving these endeavours appears boundless as architects continually explore novel avenues to integrate renewable technologies into aesthetically pleasing and functionally efficient structures. Notably, conventional solar modules demand robust foundations capable of withstanding both the weight of the modules and the varied elements of nature. Traditionally, structures inspired by trees have been composed of steel, chosen for its commendable mechanical characteristics (Avdic et al., 2013). However, the contemporary landscape of sustainable architecture showcases a departure from traditional materials and methods. A noteworthy example is the evolution of the smart palm tree, which eschews the conventional steel framework in favour of a lighter and sturdier construction using fibre-reinforced plastic. The incorporation of nine leaf-shaped photovoltaic modules not only enhances the overall design aesthetics but also demonstrates a strategic shift towards materials that offer superior durability and reduced environmental impact compared to previous prototypes. Furthermore, the utilization of fibre-reinforced plastic enables the smart palm tree to achieve a delicate balance between structural strength and weight, contributing to its versatility and adaptability in various environmental contexts. In addition to the material innovation, the current iteration of the smart palm tree incorporates protective measures against environmental degradation. UV and humidity protections have been meticulously integrated to minimize maintenance requirements, ensuring the sustained functionality and aesthetic appeal of the structure over time (O'Keefe, 2015). This dual focus on structural resilience and ease of maintenance exemplifies a holistic approach to sustainable architecture, addressing both the immediate performance needs and the long-term environmental impact of the design.

In a parallel vein of research, Kumar et al. (2022a) have proposed a metallic tree structure engineered to withstand extreme weather conditions, including storms with wind speeds of up to 200 km/h. This represents a significant stride in developing architectural solutions capable of withstanding nature's forces, attesting to the ongoing commitment within the architectural community to create resilient and adaptive structures that seamlessly integrate with the environment. Collectively, these innovative approaches underscore the dynamic landscape of sustainable architecture and its capacity to blend aesthetic ingenuity with technological advancements, ushering in a new era of environmentally conscious design.

2.4.5. Efficiency

The efficiency of solar trees depends on many factors, such as the quality of the modules used, the incidence angle of solar irradiation, and the ratio of shadows on the modules to each other. Researchers have not mentioned the efficiency of solar trees due to the factors mentioned. According to technical analysis, a simple solar tree design is more efficient than others, as a single layer of PV modules faces the sun. However, the solar tree is more effective than the regular PV system since the temperature has a significant effect. A new configuration of the solar tree was built in Algeria and compared with the same number of PV cells of a regular PV system; the result shows the solar tree can produce 22.6 % more power than the regular PV module at 2:00 p.m. (Baci et al., 2020). A solar tree was built in Shiraz, Iran, to mix urban architectural beauty and solar energy; the result shows a 12% increase in annual efficiency compared with land-based PV systems (Rajae and Jalali, 2021). A water pump based on the solar tree was built in India for agricultural irrigation purposes. The solar tree system with the battery cost has been studied, and the results showed a payback period of about 10.5 years (Kumar et al., 2022b). Researchers focused much on enhancing the efficiency of PV modules, considering various cooling techniques. For instance, Amr et al. (2019) experimentally investigated the performance improvement of a PV module using fins as a promising passive cooling technique coupled with ventilation air. They showed that the cell temperature was rising linearly with the increased ambient temperature, with and without fins, regardless of air ventilation. Fins helped to reduce the cell temperature by roughly 4 °C to 5 °C. Shukla et al. (2017) discussed the PV module efficiency enhancement by natural and forced air cooling, hydraulic cooling, heat pipe cooling, cooling with phase change materials, and thermoelectric cooling as effective cooling strategies. Besides, it has been reported by Alshibil et al. (2022) that the electrical performance of the photovoltaic/thermal system could outperform the PV module by up to 10.32%. However, the strategy considers an instance of temperature reduction of the PV cell, resulting in heat extraction from the PV module and eventually improving the electrical efficiency. Praveenkumar et al. (2022) suggested a fanless heat pipe sink for cooling PV modules. The cooled module has dropped the average temperature of the PV module by up to 6.73 °C. A study (AlAmri et al., 2021) was conducted on solar PV modules in a desert environment, adopting a passive cooling design through an analytical model. The study results showed that PV productivity could be increased by 8.7% and 6.5% during summer and winter, respectively. Another study proposed a new hybrid roof design that allows full-spectrum solar light to pass through using spectral splitting covering, providing better harvesting light by the PV cells and covering the greenhouse by concentrating spectral splitting utilization (Ma et al., 2022). Many other passive and active techniques have been investigated in the literature studies and showed notable PV performance enhancement (Elminshawy et al., 2022).

2.4.6. Maximum power tracking

One of the primary distinctions delineating traditional Photovoltaic (PV) systems from solar PV tree technology lies in the nuanced reception of irradiance by individual modules. This discrepancy underscores the dynamic nature of solar irradiance, necessitating the integration of Maximum Power Point Tracking (MPPT) mechanisms within solar tree systems to optimize power output continually. The construction of a solar tree unfolds through two principal

methodologies: the first involves structuring the solar tree based on direct solar irradiance, while the second method relies on the strategic optimization of each solar module's placement within the solar tree structure (Hyder et al., 2018c). This dual approach signifies a deliberate response to the variability in solar irradiance, underscoring the importance of adaptive strategies for maximizing energy generation.

The intricacies of solar tree design and simulation are elucidated through a comprehensive flowchart, depicted in Fig. 2.16, which delineates the main procedural steps for each module. This visualization encapsulates the intricate sequence of design considerations and simulation processes involved in optimizing solar tree configurations. The culmination of these steps involves the summation of individual module results to calculate the annual energy production of the solar tree. Beyond a mere schematic representation, this flowchart serves as a roadmap for engineers and researchers, guiding them through the intricate process of solar tree design with a focus on achieving maximum energy efficiency.

In essence, this holistic framework acknowledges the dual challenge posed by variable solar irradiance and the need for precise module optimization within the solar tree. The integration of intelligent strategies not only reflects a response to the inherent irregularities in solar energy availability but also signifies a commitment to the overarching goal of maximizing energy harvest from these innovative structures. As solar PV tree technology continues to evolve, this comprehensive approach ensures that design and optimization strategies align with the dynamic nature of solar energy resources, positioning solar trees as effective and adaptive contributors to sustainable energy solutions.

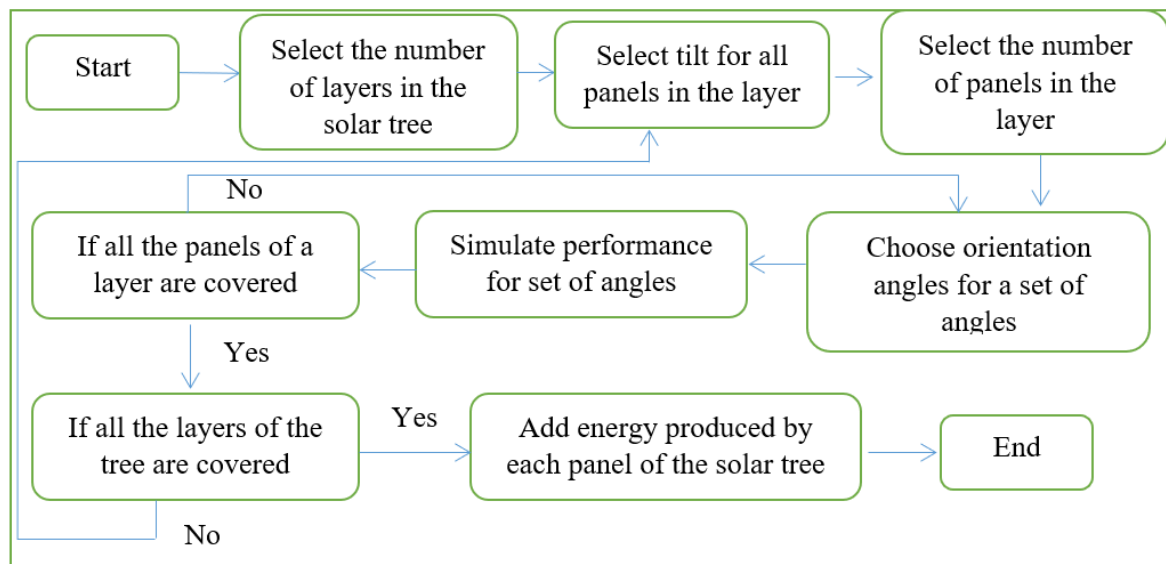

Fig. 2.16. Flowchart of the optimization procedure for a solar tree (Hyder et al., 2018c)

The algorithm delineated by Dey et al. (2018) has been effectively employed through MATLAB to discern the optimal position points (x, y, z) within the intricately generated scheme space, a visual representation of which is elucidated in Fig. 2.17(a). This comprehensive configuration encompasses critical specifications, including the number of solar modules to be strategically positioned (n) and the specific orientations of these modules

(β_n, γ_n). The discussion delves into the intricacies of the Maximum Power Point Tracking (MPPT) procedure within the solar tree framework, with a primary objective of maximizing sunlight capture by the solar modules while concurrently minimizing shading effects over an extended period. The integration of computer software serves as a facilitator in determining the ideal number and positioning of solar modules within the intricate structure of the solar tree.

Through rigorous simulation exercises, it has been discerned that the proposed hybrid electromechanical MPPT method yields a substantial enhancement in energy gain, amounting to 203.5 W hr/day. This denotes a notable 27.7% increase in the harvested energy, exemplifying the tangible benefits derived from the optimized MPPT process. However, it is essential to underscore that the realized percentage benefit is intricately linked to the specific operational context, emphasizing the need for a contextual understanding of the system's dynamics (Abdelsalam et al., 2017). Moreover, the evolution of solar tree technology is evidenced by the modifications made to the flowchart outlined in (Dey and Pesala, 2020). The refined design processes encapsulated within this updated flowchart pivot around the meticulous optimization of the shading percentage. This strategic focus aligns with the overarching objective of maximizing energy extraction from the solar tree, as vividly illustrated in Fig. 2.17(b). These iterative design and simulation steps collectively underscore a comprehensive approach aimed at augmenting the efficiency of solar tree structures. The integration of sophisticated algorithms, exemplified by the details in (Dey et al., 2018; Liu et al., 2018), and the ongoing refinement of design processes, as evident in (Dey and Pesala, 2020; Kumar et al., 2022a), collectively contribute to the continuous advancement of solar tree technology. This progress is crucial in aligning solar tree systems with the imperative of achieving optimal energy harvesting outcomes across diverse operational contexts, marking a significant stride toward sustainable and efficient solar energy utilization.

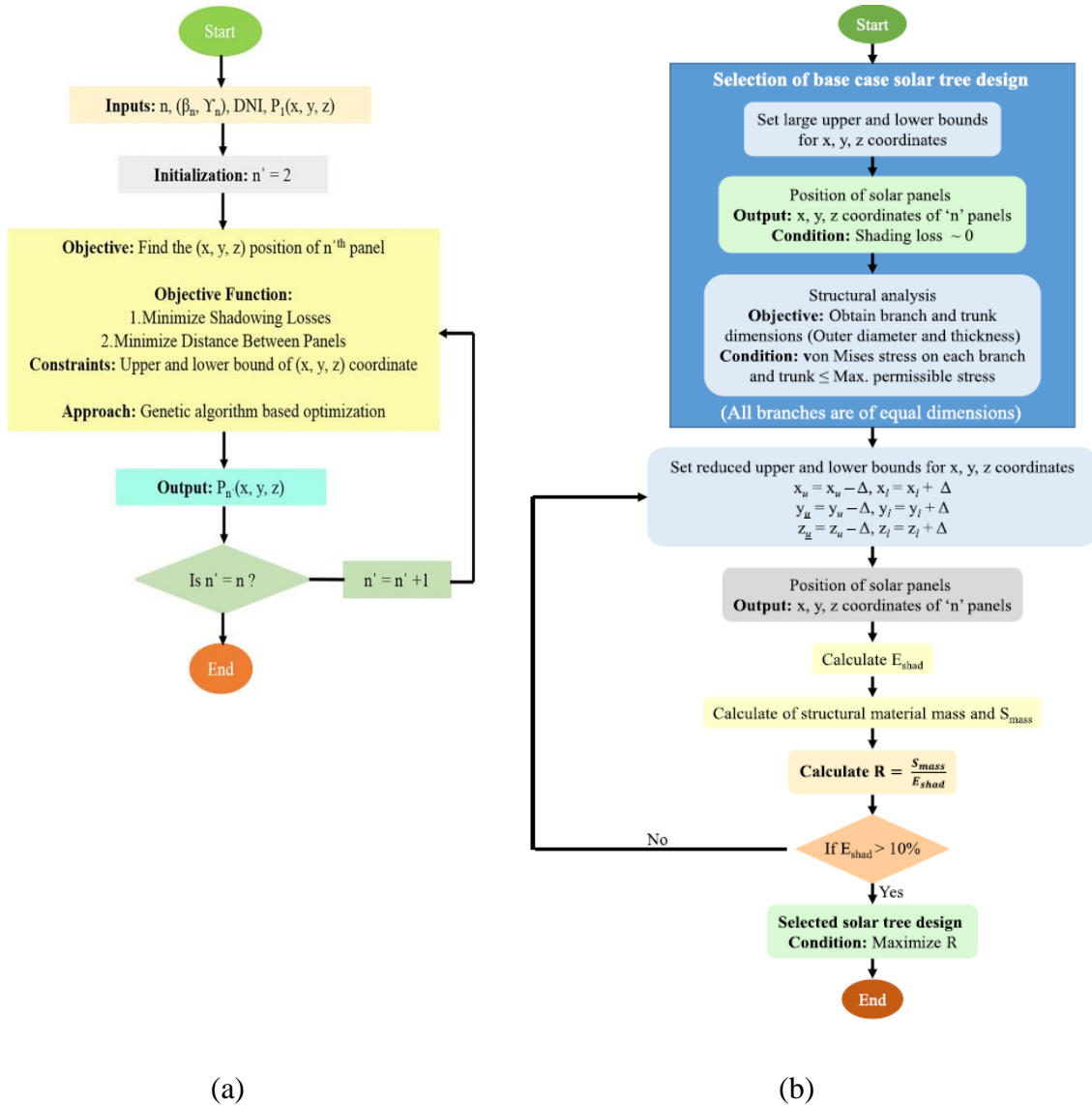

Fig. 2.17. MPPT for a solar tree, (a) MPPT flowchart (Dey et al., 2018), (b) Modified MPPT flowchart (Dey and Pesala, 2020)

2.4.7. Cost

The endeavour led by the Central Mechanical Engineering Research Institute (CSIR) to develop a 5-kW solar-powered Multilayered Branch Solar System (MBSS) at a cost of \$7,500 underscores the commitment to advancing solar energy solutions in India (Vardhan, 2016). This project aligns with the broader goal of harnessing renewable energy and contributing to sustainable development. However, the complexity of the (FPST) results in a higher cost structure (Hyder et al., 2018c), as evident in the \$680 price tag for a 120-W FPST (Chitra et al., 2019). Similarly, the High-Density Solar Tree (HDST), designed to maximize energy output through a larger number of integrated modules, commands higher costs, emphasizing the correlation between enhanced performance and investment (Hirani, 2020). The development of the world's largest solar tree at an estimated cost of \$9,560 reflects the scale and ambition behind solar energy initiatives, positioning solar trees as prominent symbols of innovation and sustainability (Bandyopadhyay, 2020). Despite their impressive capabilities,

solar tree modules are priced at double the rate of traditional PV solar modules, with an associated cost of \$1,300 per kilowatt-hour of energy produced. However, this cost diminishes with an increase in the total power output of a single tree, indicating economies of scale (IndiaMART, 2019).

The elevated costs attributed to solar trees stem from various factors, including the incorporation of robust steel structures and aesthetically pleasing designs. The inherent complexity and innovative features of solar tree designs contribute to their higher price points, reflecting a balance between technological sophistication and visual appeal. Notably, the payback period for smaller-scale applications is estimated to be up to 12 years, highlighting the long-term investment horizon associated with solar tree installations (Gupta, 2017).

The premium pricing of a 7.5-kW smart palm tree, exceeding \$25,000, underscores the emphasis on quality and modern technological structures within the solar tree landscape (Solar Panels in Palm, 2016). Fig. 2.18 provides a visual comparison of prices between different types of solar trees and traditional PV systems, illustrating the diverse economic considerations associated with these innovative energy solutions. It is crucial to recognize that the absence of batteries in some solar tree designs, mitigating the most expensive component of solar systems, plays a pivotal role in cost reduction.

In the grander context, these endeavours represent a convergence of technological innovation, environmental sustainability, and economic considerations. Despite the higher upfront costs, solar trees epitomize a transition towards cleaner and more sustainable energy sources, contributing to a future where renewable energy solutions play a pivotal role in meeting global energy demands.

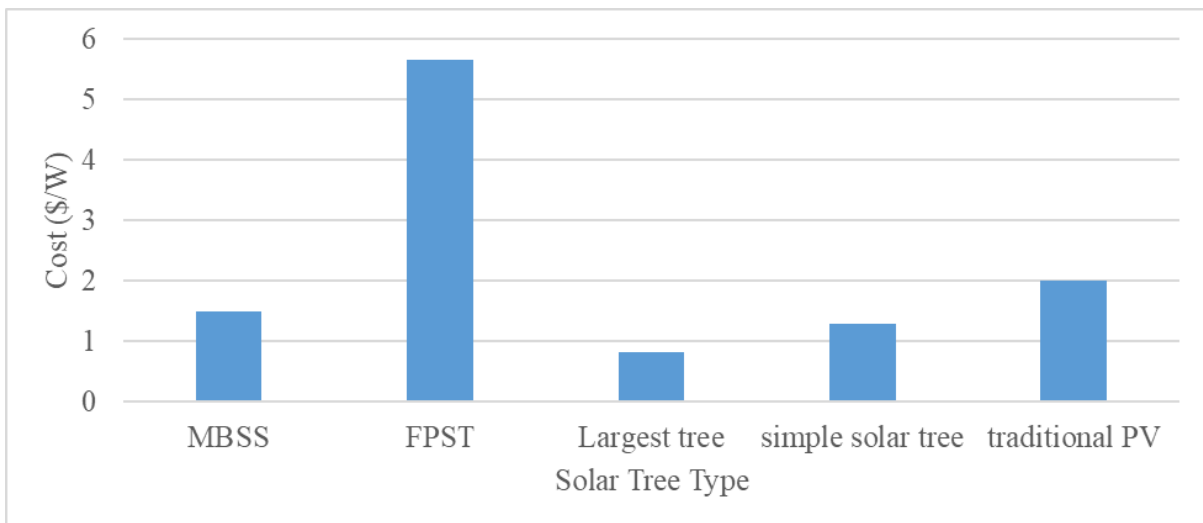

Fig. 2.18. Cost of commercially available solar trees and traditional PV system

2.5. Solar tree commercialization

Trees stand as one of nature's most fundamental and awe-inspiring features, distinguished by their diverse forms and colours. The intersection of nature's elegance with cutting-edge technology has given rise to solar trees, a testament to the harmonious integration of ecological inspiration and human ingenuity. In the realm of solar energy, manufacturing companies

leverage the expertise of skilled engineers capable of customizing solar tree designs to meet the specific demands of customers, research centres, institutions, corporations, and governmental entities. This adaptability ensures that solar trees find application across a broad spectrum of contexts, demonstrating their versatility and relevance in various settings. Solar trees, with their innovative designs, go beyond mere utilitarian considerations. They embody a fusion of aesthetics and functionality, presenting an alternative to traditional ground-mounted solar cells. This evolution in solar technology introduces a novel approach to energy capture and underscores the transformative potential of sustainable energy solutions. The comparison between traditional trees and solar trees extends beyond their aesthetic appeal to a pragmatic evaluation from a commercial standpoint. By juxtaposing these modern solar structures with conventional ground-based solar cells, a comprehensive analysis emerges, shedding light on the economic implications and technological advancements associated with solar trees.

In contrast to their organic counterparts, solar trees manufactured by engineering companies represent a deliberate and controllable approach to energy harvesting. The capacity to tailor quantities, sizes, and shapes according to specific requirements highlights the adaptability and scalability of solar tree technology. This tailored design capability is particularly advantageous for meeting the diverse needs of stakeholders ranging from individual consumers to large-scale institutions and government entities. The multifaceted applications of solar trees extend beyond their role as energy generators, positioning them as iconic symbols of sustainable innovation and environmentally conscious design. This juxtaposition between traditional trees and solar trees not only underscores the evolution of solar technology but also serves as a tangible example of how human innovation can draw inspiration from the natural world. As society increasingly gravitates towards sustainable practices, solar trees stand at the intersection of ecological mindfulness and technological progress. Through this lens, they become more than just functional energy structures; they embody a commitment to a greener future, where technology and nature coexist synergistically to address the growing demand for clean and renewable energy sources.

2.5.1. Conventional PV and solar tree technologies

Differences exist between conventional PV systems and solar trees, such as the land needed for installation and system cost. The comparison below, as shown in Table 2.1, clarifies the primary differences between the two types to familiarize the readers with the requirements for each type and the type of application that can be used more.

Table 2.1. Comparison between conventional PV and solar tree systems

Parameter	Conventional PV	Solar tree
Power produced	Diversification of the productive capacity from small to large stations up to 2 MW	Less power per tree up to 11.5 kW
PV system cost	Simple structure design and relatively low cost	Generally, it is more costly, but it depends on the complex 3D design and the application
Land footprint	Large land footprint in general, and it depends on PV system size, the footprint factor is up to 700 W/m ²	Less footprint: due to the tree containing many layers of PV modules on a single stem, the footprint factor is up to 11500 W/m ²
Shading	Less shading effect	More shading effect because of many PV layers and random orientation of modules
Amount of sunlight captured per square meter of soil area	Less due to its extensive array design consuming more area	More as modules are arranged on many layers, which takes less area
Applications	Mainly for generating electricity	Many applications, such as integrating art with technology
Suitable angles of incidence	More efficient than the tree at low angles of incidence (0°–20°)	More efficient at higher angles of incidence (40°–80°)
Capture during peak sunshine hours	High as modules are oriented to face the sun directly during peak sunshine hours	Modules are angled in different directions, and not all modules face the sun directly during peak sunlight hours; thus, the energy generated is relatively low
Art and appearance	Lack of art and aesthetics	Pleasing aesthetic appearance

2.5.2. Comparison among commercial solar trees

Manufacturing companies compete to attract customers and meet their desires according to the requirements of institutions or individuals who want to obtain solar trees. The comparison below as shown in Table 2.2, shows most of the differences among solar tree types to determine the type of solar tree in advance with the manufacturer. Four solar trees are the most widely used.

Table 2.2. Comparison of popular solar tree types

Parameter	MBSS	RLST	Simple solar tree	Smart palm tree
Power	Generate electric power on demand.	Limited electric power generation.	Generating electricity on demand. Building the largest solar tree in the world.	Limited electric power generation.
Structural design	The tree structure consists of a single stem with multiple branches and many layers, and shapes can also be placed (FPST).	Consists of a sinuous tree constructed of steel pipes, measuring 5.5 m, supporting a light bubble, in which there exist 38 solar PV modules.	The tree structure consists of a single stem with solar panels distributed on a single layer, directed toward the sun.	A sophisticated structure of a single stem mixed with plastic and solar panels circulated on a single layer directed toward the sun.
Efficiency	Lower efficiency due to the shadow of the modules on each other.	Lower efficiency due to vertical panel installation.	High efficiency because the panels face the sun.	High efficiency because the panels face the sun.
Appearance	Unpleasant solar tree.	Remarkably beautiful solar tree.	It is considered a shade solar tree.	Remarkably beautiful solar tree.
Pros	Less expensive than other designs.	Designs that are influenced by nature.	The best tree to electricity-generating.	Can be used for tourism area.
Cons	All panels are oriented in the same direction; thus, light collection is less efficient.	Limited power generation.	Large scale and needs a strong structure to meet the weather conditions.	Extremely expensive.
Cost/Watt	\$1.5/W, which is an acceptable cost compared with the traditional system.	High cost and custom-made.	\$0.84/W, which is the cheapest one.	\$3.5/W, which is the expensive one.

2.6. Summary of literature review

A significant development in the applications of PV cells, their prices, and their efficiency has been observed in the last 15 years, and materials play an essential role in this scientific development. Trees are one of nature's most fundamental features; their forms and colours differentiate them. Compared with traditional PV technology, solar tree technology can absorb solar energy more effectively in any geographic area and season. Compared with land-based PV systems, solar trees meet today's most pressing social, cultural, and environmental concerns with a considerably smaller land footprint. The solar tree design can become a model of green technology, with a wide variety of research applications in the PV sector. The main interest is in solar cells and tree structures, as the high price of solar trees is due to the design cost.

Solar power serves essential roles in urban and rural areas, addressing diverse needs. Solar energy systems efficiently meet residential electricity demands in crowded urban spaces where land is scarce. Meanwhile, in rural settings without grid access, solar power becomes a lifeline, providing energy for farm machinery and water pumps. It also extends to street lighting, enhancing safety and aesthetics on highways and urban streets. Gardens and pathways benefit from solar-powered streetlights, adding functionality and beauty. Moreover, solar energy transforms office parking lots and manufacturing units, meeting industry energy needs and improving visual appeal. Beyond looks, solar energy meets charging needs for mobiles, laptops, and electronic devices in airports, parks, and malls, offering convenient and sustainable solutions. The commitment to sustainability extends to electric vehicle charging stations, promoting safe and eco-friendly transportation. Additionally, solar power supports information centres, billboards, and notice boards, ensuring isolated locations have access to energy for informational and advertising purposes. Lastly, vending machines, water coolers, and related items receive a reliable power supply through solar energy, contributing to energy efficiency in various public spaces.

Numerous scholars have dedicated their efforts to enhancing the efficacy of photovoltaic cells, specifically focusing on solar trees. However, this review reveals a notable absence of attention towards altering the external morphology of photovoltaic cells and selecting geometric configurations to optimize solar energy capture throughout the diurnal cycle. This deficiency extends to incorporating aesthetic considerations in urban settings and conceptualising structures resembling trees, thereby amalgamating artistic elements with technological functionality to enhance the visual appeal of the environment while concurrently harnessing solar power. Stemming from the fusion of nature-inspired aesthetics and technological ingenuity, diverse spherical and semi-spherical structures were constructed to investigate their impact on electricity generation systematically. The primary objectives encompassed the reduction of ground space occupied by photovoltaic systems, the infusion of aesthetic elements, and the facilitation of heat dissipation to preserve the operational efficiency of the photovoltaic cells.

3. MATERIALS AND METHODS

This chapter gives a thorough overview of the materials, methods, and tools used in the research, including in-depth explanations of the scientific methods applied in the experimental measurements. Many designs and shapes of PV modules were tested and studied to enhance power generation and reduce the land footprint of the PV systems. The explanation also includes the research process, outlining how the study was carried out, the techniques used to obtain the data, and the visual analyses that were carried out in order to achieve the objectives of the study.

3.1. Study location

The experimental work to investigate the solar tree, spherical and hemispherical PV configurations was developed, built, and tested in the solar energy laboratory of the Hungarian University of Agricultural and Life Sciences (MATE) using many types of monocrystalline, polycrystalline, and flexible PV modules, Gödöllő, Hungary, along different seasons from 2021 to 2023 to study the PV power generation behaviour. The geographical locations of the setup are (47.5944254 N, 19.3670737 E), 210 m above sea level, located 32 km northeast of Budapest, as shown in Fig. 3.1. In Gödöllő, the summer is warm with an average maximum ambient temperature of about 28 °C. Besides, winter is freezing, snowy, and partly cloudy year-round, with an average maximum temperature of about 4 °C. The location has a relatively clear sky and moderate temperatures in the spring and autumn seasons.

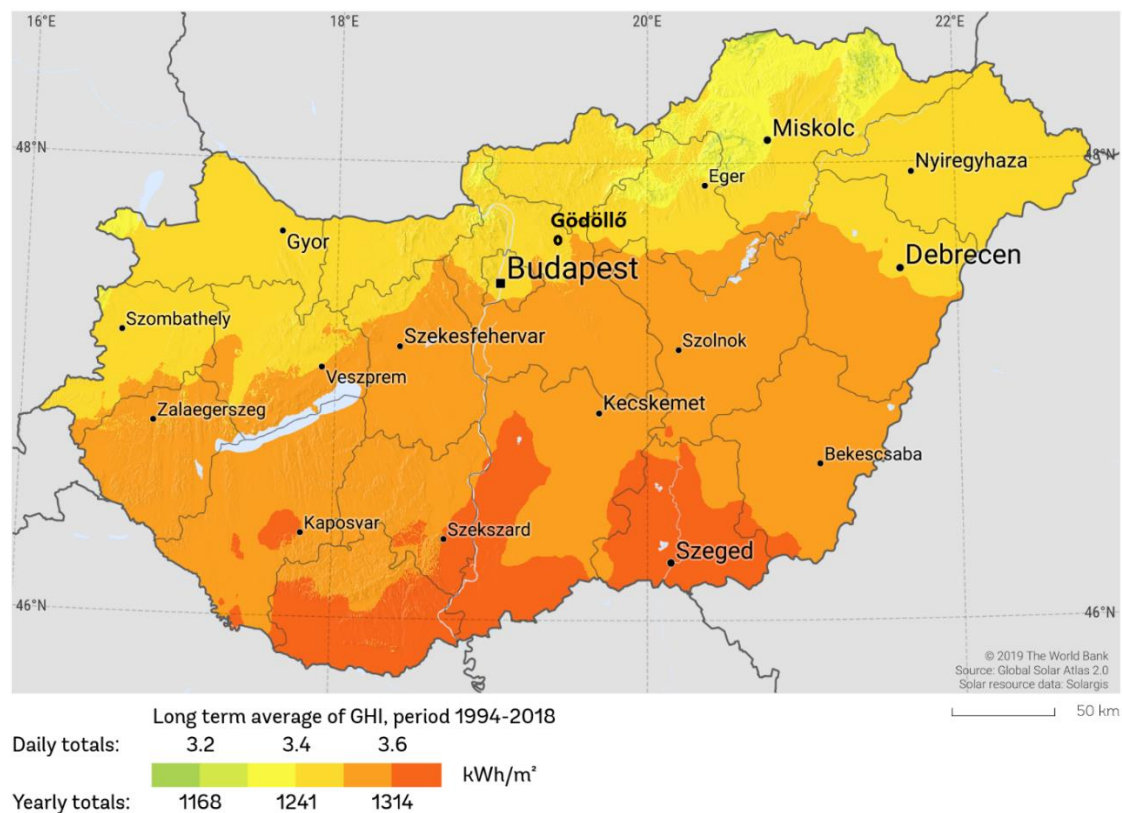

Fig. 3.1. Location of the MATE solar laboratory

Hungary generally has better PV application opportunities than other European locations since sunlight exposure varies from 1900 to 2200 hours per year (Kumar et al., 2021). The average annual global irradiation in Gödöllő is about $3.38 \text{ kWh m}^{-2} \text{ d}^{-1}$, while the average yearly diffuse irradiation is $1.66 \text{ kWh m}^{-2} \text{ d}^{-1}$ (Kafui et al., 2019). Furthermore, the optimization of electrical power generation through photovoltaic cell technology involves a meticulous consideration of solar module orientation. Empirical investigations have revealed a direct correlation between the efficiency of solar modules and the angle of incidence of solar rays. This necessitates a nuanced approach to the tilt angle, a parameter subject to geographical disparities and seasonal variations. An additional layer of sophistication emerges in the determination of the rate of inclination, wherein photovoltaic modules typically align with the degrees of latitude throughout the annual solar cycle.

The temporal dynamics of electricity production are noteworthy, particularly for systems lacking a solar tracker. The designated operational period typically spans from 10:00 a.m. to 2:00 p.m., emphasizing the significance of this time window for optimal energy yield. Moreover, the imperative of maintaining the cleanliness of solar modules cannot be overstated. The sensitivity of these modules to dust underscores the need for regular cleaning to prevent any impediments in solar energy absorption.

In essence, the quest for maximizing electrical power output from photovoltaic technology demands a multifaceted approach, encompassing precise spatial and temporal considerations, coupled with a vigilant maintenance regimen to ensure the sustained efficiency of solar modules.

3.2. Materials and instrumentations

Photovoltaic technology has been characterized by its spread worldwide because it outfits a wide range of applications and can be applied in different atmospheric conditions as it depends on sunlight (Sredenšek et al., 2021). Within sunlight absorption technology, three basic types can be found within most applications that use this technology, which are (monocrystalline, polycrystalline, and thin film). It is worth noting that there are some differences in manufacturing and efficiency between them (Kesler et al., 2014). The manufacturing procedure necessitates two things: first, a material in which light absorption raises an electron's energy state, and second, the passage of that higher energy electron from the solar cell onto an external circuit. After dissipating its energy in the external circuit, the electron returns to the solar cell. The requirements for photovoltaic energy conversion can be met using several materials and technologies. Still, in reality, practically all photovoltaic energy conversion uses semiconductor materials in the form of a p-n junction (Mohammad Bagher, 2015).

Throughout the experimental phase, a variety of measuring instruments and different types of PV modules were utilized to gauge a range of operational parameters and characteristics inherent to PV systems. These parameters include:

3.2.1. Monocrystalline PV module

Monocrystalline solar photovoltaic (PV) modules represent the most advanced and historically established type of PV technology. The nomenclature "monocrystalline" is attributed to the

utilization of single-crystal silicon structures in these panels (Singh and Agrahari, 2019). The most efficient solar modules were contracted and supplied by Shenzhen Xiangxinrui Solar Energy Co., Ltd Company, and two scales with dimensions (180×60 and 130×40) were purchased, as Table 3.1 shows the specifications for solar cells.

Table 3.1. Specifications of the solar module as provided by the manufacturer

Parameter	First type	Second type
Maximum power	1.8 W	1.1 W
Rated power	1.3 W	0.9 W
Maximum voltage (V_{max})	2 V	2 V
Maximum current (I_{max})	0.9 A	0.55 A
Open-circuit voltage (V_{oc})	2.36 V	2.36 V
Short-circuit current (I_{sc})	0.99 A	0.605 A
Dimension (L×W×T)	180 ×60 ×3mm	130×40×3mm
Cell efficiency	22%	22%

3.2.2. Polycrystalline PV module

The most separated type in the world market because of several parameters such as cost, efficiency, and temperature sensitivity. The PV modules from Siemens solar industries used in this research were available in the laboratory and were exploited to compare the efficiency with other types of solar modules. Table 3.2 shows the specifications of these types of solar cells.

Table 3.2. Specifications of the polycrystalline PV module (Almadhhachi et al., 2022b)

Maximum power	3.3 W
Rated power	3 W
Maximum voltage (V_{max})	12 V
Maximum current (I_{max})	0.250 A
Open-circuit voltage (V_{oc})	13.2 V
Short-circuit current (I_{sc})	0.260 A
Dimension (L×W×T)	480 ×370 ×4mm
Cell efficiency	16%

3.2.3. Thin film PV module

Flexible modules have several advantages, the most important of which is the ability to bend and fold, and it has a lower thermal impact factor than other types of solar cells, as literature mentioned in chapter 2. Two types of flexible cells were purchased. The first type is a leaf

shape PV module from Shenzhen Winxu Energy Technology Co., Ltd Company, as shown in Table 3.3, and the second is a rectangular shape PV module with more flexibility from Zhuhai Bro Renewable Energy Technology Co., Ltd Company, as shown in Table 3.4.

Table 3.3. Specifications of the solar leaf module as provided by the manufacturer (Shenzhen Winxu Energy Technology Co., Ltd)

Maximum power	1.56 W
Rated power	1.3 W
Maximum voltage (V_{max})	2 V
Maximum current (I_{max})	0.650 A
Open-circuit voltage (V_{oc})	2.2 V
Short-circuit current (I_{sc})	0.710 A
Dimension (L×W×T)	173 ×38 ×1mm
Cell efficiency	17%

Table 3.4. Specifications of the solar module as provided by the manufacturer (Zhuhai Bro Renewable Energy Technology Co., Ltd)

Maximum power	0.13 W
Rated power	0.1 W
Maximum voltage (V_{max})	1.5 V
Maximum current (I_{max})	0.07 A
Open-circuit voltage (V_{oc})	1.65 V
Short-circuit current (I_{sc})	0.09 A
Dimension (L×W×T)	110 ×30 ×2 mm
Cell efficiency	11%

3.2.4. Pyranometer

A pyranometer used to track the entire solar radiation spectrum during the experimental days is adopted. It is frequently used for environmental monitoring, solar resource evaluation, and solar power performance with uncertainty ($\pm 10 \text{ W/m}^2$) and is directly connected to a scientific data logger. The pyranometer was designed to measure the solar radiation flux density from a 180° field of view angle with a vast wavelength range, as shown in Fig. 3.2 (a).

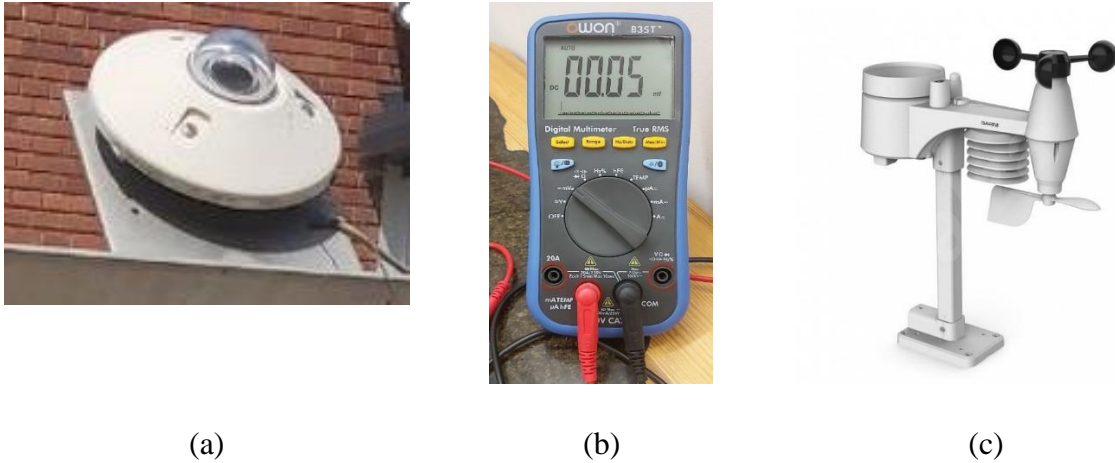

Fig. 3.2. Measuring instruments

3.2.5. Multimeter

A multimeter (model OWON B35T+), as shown in Fig. 3.2 (b), can record the voltage with accuracy ($\pm 0.5\%$) and current with uncertainty ($\pm 0.8\%$) for direct current (DC) electrical cycles for specific periods. The recorded data can be extracted by linking the multimeter and cell phone via Bluetooth. The multimeters have three uses: a thermometer, data logger, and multimeter. Bluetooth connectivity and the True-RMS feature are also features of the B35T. It may also be linked to an Android smartphone. The program allows numerous connections to be active altogether, enabling multiple measurements with different multimeters.

3.2.6. Weather station

The GARNI model weather station can monitor barometric pressure, temperature, humidity, wind speed and direction, as shown in Fig. 3.2 (c). All of these can be displayed on a large LCD. Like most devices in this category, the device includes a clock and displays the current date.

3.2.7. Datalogger

An Arduino Smart DEN data logger with a 32-channel (16 digital, eight analogue and eight thermistor inputs) with uncertainty ($\pm 0.2\%$) DC power supply was employed to gather all the parameter data connected to a laptop to display and record data, as shown in Fig. 3.3. The temperature sensors (NTC thermistors type B57500M (from -55 to $+155\text{ }^{\circ}\text{C}$)) and the solar radiation sensor (RS-RA-*-AL) with uncertainty ($\pm 1\text{ W/m}^2$) can be connected to the datalogger directly. In addition to continuous data recording to an SD card, The Web interface allows users to configure the smart DEN Logger, monitor current measurements, and access logged files for download or graphical visualization. Supported by DRMv3.

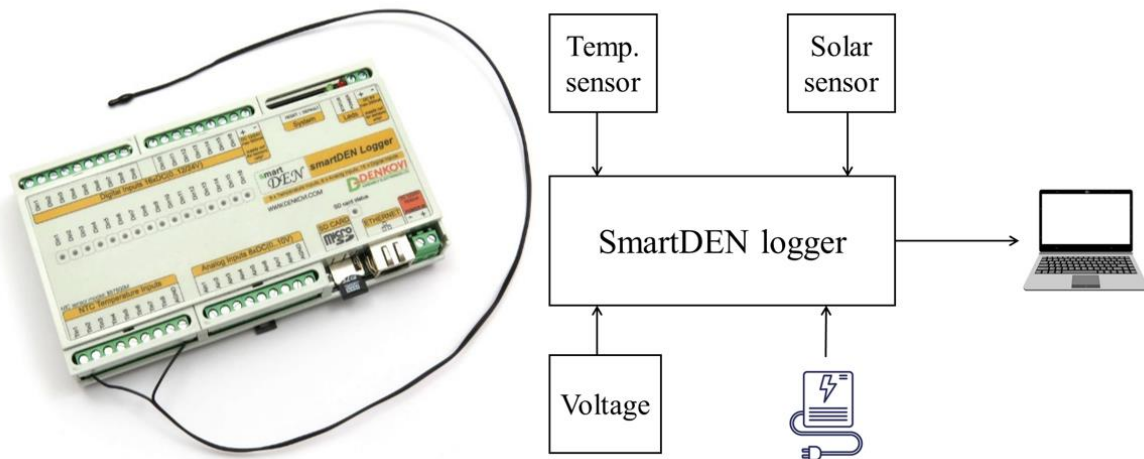

Fig. 3.3. Data logger, temperature sensor and block diagram

3.3. PV configuration types

The direct conversion of solar lights into electrical energy, commonly referred to as photovoltaic (PV) technology, constitutes a paramount technological advancement in the harnessing of solar energy (Jessen et al., 2018). Conventional photovoltaic systems typically exhibit a flat configuration, with most installations characterized by a minimalist black appearance. However, in recent years, the emergence of solar trees has challenged this conventional design, offering an aesthetically pleasing and environmentally friendly alternative to conventional solar panels. These structures not only harness solar energy but also contribute to urban beautification, fostering a greater public acceptance of renewable energy sources.

Beyond the conventional flat design, researchers have explored the potential of unconventional shapes for photovoltaic systems (Vyas et al., 2022). Geometric concepts such as concave and convex forms have been investigated to enhance the efficiency of solar modules (Arissetyadhi et al., 2020). However, most of these studies have been confined to simulated environments and idealized conditions, requiring further real-world validation to assess their practicality and impact on overall energy generation. The external design of the solar PV modules was changed to study the effect of shape on electrical energy production.

3.3.1. Flat PV module

Planar configurations of photovoltaic (PV) systems are ubiquitously adopted across diverse scales, ranging from large-scale industrial installations to smaller, decentralized systems, for the purpose of electrical energy generation. A notable exemplification of this prevalent design paradigm is encapsulated in the creation of a flat PV module, an assembly incorporating eighteen monocrystalline modules. This modular construction aligns with the standard practice within the field, underscoring the widespread utilization of planar geometries in the fabrication of PV systems. The selection of monocrystalline modules further emphasizes a commitment to efficiency and performance, as these crystals are renowned for their superior conversion capabilities. The development of such flat PV modules contributes to the ongoing advancements in solar technology, fostering the continued evolution of reliable and scalable

solutions for the harnessing of solar energy, as shown in Fig. 3.4, (a) another flat PV module composed of twelve thin film leaf PV module, as shown in Fig. 3.4, (b) To study the characteristics of the solar PV module and compare it with other spherical and hemispherical shapes.



Fig. 3.4. Flat PV module
(a) monocrystalline PV module, (b) thin film PV module

3.3.2. Solar tracker hemispherical PV module

The adoption of hemispherical photovoltaic (PV) modules represents a strategic response to the multifaceted challenges inherent in conventional PV systems. Addressing concerns related to tilt angle, azimuth angle, land footprint, and aesthetic considerations in the final configuration, these modules have assumed paramount importance in ongoing research. Beyond mitigating these challenges, the hemispherical shape imparts a unique advantage by providing a daily perpendicular exposure to solar intensity. This inherent property not only enhances energy capture but also negates the necessity for expensive tracking technology systems, offering a cost-effective alternative for maximizing solar energy utilization (Almadhhachi et al., 2023).

In the context of this research, a meticulously crafted hemispherical structure with a diameter of 0.25 meters has been devised, as shown in Fig. 3.5. This structure integrates six leaf-shaped segments within a robust metal framework, facilitating the installation of thin-film solar modules, each strategically inclined at an optimal angle of 45 degrees to further enhance energy absorption efficiency. The amalgamation of these design features underscores a holistic approach toward addressing the technical and economic considerations associated with solar energy harvesting systems.



Fig. 3.5. Solar tracker hemispherical shape

3.3.3. Hemispherical PV module

Producing solar PV modules in spherical or hemispherical configurations presents inherent complexities, even for fabricating a spherically enveloped solar cell assembly. This complexity stems from the prevailing availability of solar cells in the market, which predominantly adopt rectangular geometries, and the moulds that are feasible for production within dedicated manufacturing facilities also conform to rectangular outlines. Consequently, the realization of spherical solar cells emerges as a formidable undertaking. Nonetheless, it is conceivable to encapsulate established spherical dimensions using adaptable solar cells that adhere to rectangular forms, albeit with certain surface areas remaining unshielded. The quantification of these exposed regions is amenable to calculation. 30 flexible PV modules covered 70% of the hemisphere surface area with a diameter of 0.3 m, as shown in Fig. 3.6.



Fig. 3.6. Hemispherical PV module

3.3.4. Spherical PV module

The amalgamation of two hemispherical photovoltaic modules results in the attainment of a cohesive spherical shape, constituting a distinctive configuration in solar module design. Notably, in the pursuit of an efficient and non-overlapping arrangement, the application of 60 flexible PV modules emerges as the optimal threshold, as shown in Fig. 3.7. This maximum limit is defined by the requirement to avert any overlap between modules, ensuring a seamless and unobstructed coverage across the surface area. Significantly, this carefully orchestrated configuration encompasses 70% of the total surface area, thereby highlighting the efficacy of this approach in harnessing solar energy across a substantial portion of the module's geometry. This precise integration of hemispherical PV modules not only underscores the technical considerations in solar array design but also contributes to the overall optimization of surface coverage for enhanced energy capture and utilization.



Fig. 3.7. Spherical PV module

3.3.5. Sunflower PV module

One of the more efficient solar trees is the simple tree, which is inspired by nature and has high power productivity (Almadhhachi et al., 2022a). The proposed solar tree has been made as a sunflower with a total diameter of 660 mm facing the sun with a southern orientation on a wooden structure to reduce costs and weight. It consists of a stem of 1800 mm in height and a flat wooden sheet cut into 15 branches holding the PV modules to create the sunflower shape as shown in Fig. 3.8. Choosing the proposed solar tree makes a comparison with the existing commercial solar trees “The smart solar tree designed by Solvis-New generation of solar energy” (IndiaMART, 2019) and “World’s largest solar tree” (Gupta, 2022).



Fig. 3.8. Sunflower PV tree

3.4. Experimental procedure

The main objective of this work is to find new designs for the PV system to harvest solar power efficiently, with less land footprint and more aesthetic shapes. The efficiency of the PV modules has been measured and compared to each other, and many new designs have been fabricated and tested.

The solar daytime in Hungary in the summertime lasts for about 15 hours. The average sunrise is at 5:25 a.m. and the average sunset is at 8:10 p.m. The highest solar irradiance occurred mid-day, between 12:00 a.m. and 02:00 p.m. The investigation into the attributes of solar modules involves the correlation of specific loads or variable resistances, each falling within a known range, to ascertain the supplied power during intervals characterized by predetermined weather conditions and solar radiation levels. Rheostat was utilized as a load cell to identify the solar PV module's maximum power point to get the maximum possible power output. During the experiment, the rheostat was attached to the modules. The investigation started by varying the rheostat's pointer while monitoring the current and voltage coming from the PV modules. Finally, the pointer's position is kept when the maximum current is seen at the maximum voltage, and the entire solar PV module's dataset is extracted.

The examination of solar modules was conducted in a comprehensive and varied manner, focusing on five distinct shapes. These shapes were meticulously scrutinized and can be categorized based on both the type of solar cells employed and the methodology of their formation, delineated into three distinct cases.

3.4.1. Testing the solar tracker hemispherical PV module

The experimental work to study the solar tracker hemispherical shape was conducted from 2:00 p.m. to 7:10 p.m. In other words, the experimental work considered half of the solar irradiance curve since the curve starts from zero at sunrise to the maximum value of the solar irradiance at mid-day to zero at sunset (the curve is symmetric) (Duffie et al., 1985). Therefore, this work considered the recorded data and measurements for the second half of the curve.

The work has been done by comparing a flat PV module with a solar tracker hemispherical PV module in two different positions to study the effect of inclination angle on the power generating and compare the results with a flat PV module of the same thin-film solar modules. The study involves an examination of a single hemisphere constructed from six flexible PV modules, with a comparative analysis against a flat plate comprising six rigid modules arranged linearly. The objective is to follow the power generation curve throughout the day and gain insights into the performance of the hemispherical configuration. To further comprehend the behaviour of the hemispheres and the corresponding power production curve, two hemispheres were interconnected in a linear arrangement with a separation of 25 cm, equivalent to the diameter of each hemisphere. This setup is compared with a flat panel containing twelve flexible PV modules arranged linearly for comparative evaluation of results.

3.4.1.1. The inclination angle of 45°

The 45° inclination angle holds significant importance in setting local solar energy systems due to its proximity to the latitude line. Additionally, most PV house systems in Hungary are installed with a 45° inclination angle facing south to optimize sunlight harvesting throughout the year (Yunus Khan et al., 2020). Consequently, this study has been conducted with a 45° inclination angle for two configurations: twelve and six-leaf flat solar modules compared to the same number of curved PV modules in tow hemispherical shapes and one hemispherical shape, respectively, as shown in Fig. 3.9. This comparative analysis aims to evaluate the performance of flat and hemispherical PV modules under the same inclination angle and orientation. By examining the power generation capacity and energy harvesting efficiency of these configurations, we can gain insights into the relative merits of each design. This information can inform the selection of appropriate PV modules for specific applications, ensuring optimal energy utilization and maximizing the potential of solar energy as a sustainable power source.

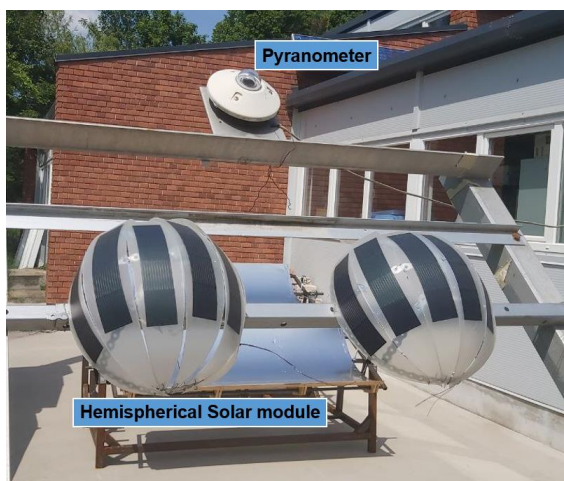

(a)

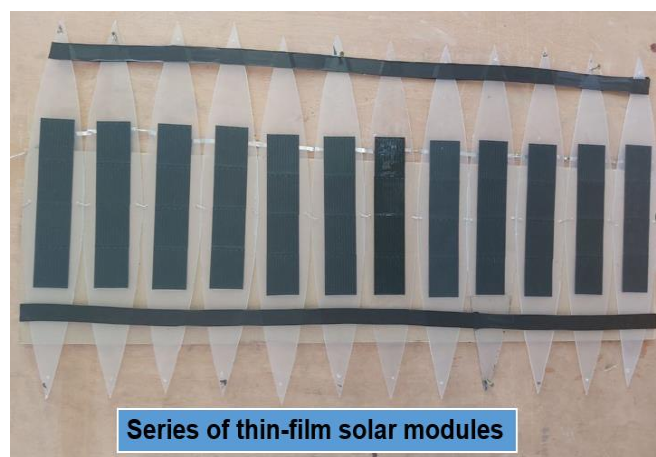

(b)

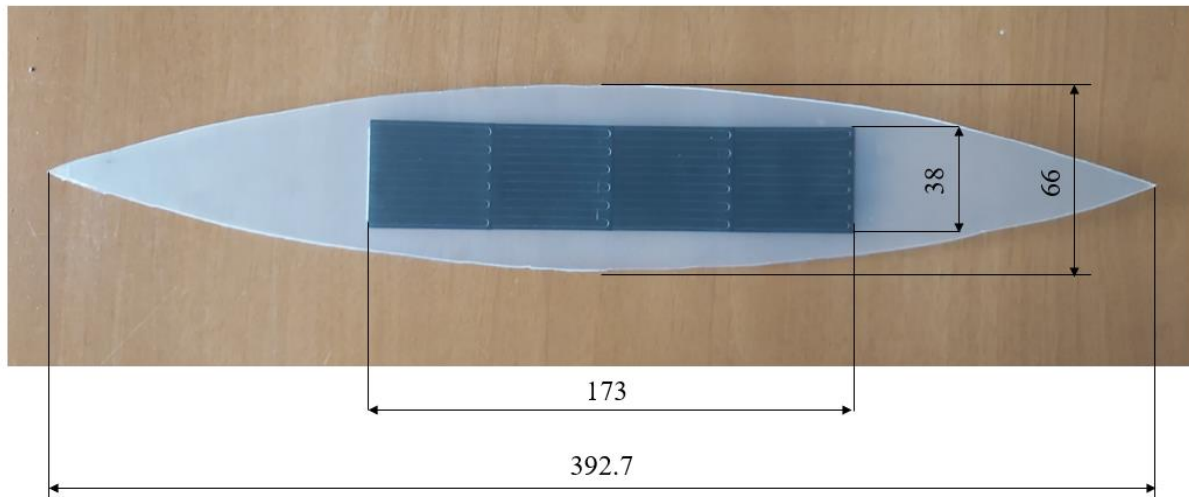

(c)

Fig. 3.9. The PV system with a 45° inclination angle, (a) two solar tracker hemispherical PV modules, (b) twelve flat solar modules, (c) leaf shape solar module (all dimensions in mm)

3.4.1.2. The inclination angle of zero-degree

The horizontal configuration of hemispherical PV modules emerges as a novel and compelling alternative to traditional flat PV arrays, particularly in applications where space is constrained. The hemispherical shape's inherent ability to capture sunlight effectively from a wider range of angles, even in horizontal orientation, stands as a key advantage, leading to a remarkable reduction in land footprint. This translates to significant cost savings in land acquisition and enhanced flexibility in deployment, allowing for installation on uneven terrain or in urban areas with limited space. Furthermore, the hemispherical shape optimizes energy harvesting throughout the day, including the early morning and late afternoon hours when flat PV arrays experience lower efficiency due to changing sun angles. Additionally, the hemispherical shape's inherent stability minimizes the need for complex and costly structural support systems, further reducing overall costs. These compelling attributes position hemispherical PV modules as a promising solution for expanding the reach of solar energy and addressing the challenges of limited space in various applications.

The hemispherical shape's ability to capture sunlight from a wider angular range, even in horizontal orientation, results in increased energy harvesting efficiency compared to flat PV arrays. This is particularly evident during the early morning and late afternoon hours when the sun's angle is lower, as the hemispherical shape can still effectively capture sunlight that would otherwise be missed by flat arrays. This enhanced efficiency translates to a higher rate of power generation, further demonstrating the advantages of hemispherical PV modules. The horizontal arrangement of hemispherical PV modules offers a promising solution for expanding the reach of solar energy in various applications, particularly in areas with limited space. Their ability to reduce land footprint, improve energy harvesting efficiency, and minimize structural support needs makes them a compelling alternative to traditional flat PV arrays. As research and development continue to refine and optimize these novel modules, their potential to revolutionize solar energy utilization is expected to expand significantly.

3.4.2. Testing the spherical and hemispherical PV module

Spherical solar modules represent a unique and innovative approach to harnessing solar energy. Different shapes and configurations were studied to understand their characteristics, including single and multiple spherical shapes and single and multiple hemispherical shapes. The aim was to explore how these configurations affect the solar PV module efficiency and overall performance, considering their arrangement, connections, and distances.

3.4.2.1. Single spherical shape

A single spherical solar module consists of a single spherical structure designed to capture sunlight from all directions. 60 flexible PV modules parallel connected covered a polyester spherical shape to produce a single ball with a diameter of 30 cm, 2 m high from the ground. The spherical shape maximizes exposure to sunlight throughout the day, making it suitable for locations with changing sun angles. Solar energy is continuously collected throughout the day, from the early morning rays to the setting sun, presenting a unique opportunity to examine the performance characteristics of hemispherical solar collectors. These innovative designs, with their encompassing shape, boast the potential to optimize energy harvesting efficiency over the course of the day. By comparing the power generated by spherical collectors with that of conventional flat-plate collectors, researchers can gain a deeper understanding of the shape and behaviour of the electric power generation curve, revealing insights into the relative merits of each design. Such comparative analysis can inform the selection of the most suitable solar collector configuration for specific applications, ensuring optimal energy utilization and maximizing the potential of solar energy as a sustainable power source.

3.4.2.2. Three spherical shapes

The continuous availability of sunlight from early morning to sunset presents a unique opportunity to investigate the performance characteristics of three-sphere solar modules, as shown in Fig 3.10. These innovative designs, characterized by their unique shape, hold the potential to optimize energy harvesting efficiency throughout the day.

By comparing the power generated by three-sphere and flat-plate collectors, the acquisition of significant insights into the structure and behaviour of the electric power generation curve can be achieved. This comparative analysis can inform the selection of the most suitable solar collector configuration for specific applications, ensuring optimal energy utilization and maximizing the potential of solar energy as a sustainable power source.



Fig. 3.10. Three spherical PV module

Additionally, the development of artefactual solar trees, which mimic the natural form of trees, offers the potential to integrate solar energy production into urban landscapes in a visually appealing and aesthetically pleasing manner. These solar trees can be designed to accommodate various energy needs, from powering individual homes to providing electricity for public spaces. As research and development continue, the potential of solar trees is expected to grow, making them a promising solution for enhancing the aesthetic appeal and sustainability of urban environments. Artefactual solar trees are a relatively new concept, but they have the potential to revolutionize the way we generate and utilize solar energy. Combining the aesthetics of trees with the efficiency of solar modules allows these structures to be seamlessly integrated into our urban landscapes, providing a clean and renewable power source.

3.4.2.3. Single hemispherical shape

A single hemispherical shape captures sunlight from a half-sphere, making it particularly suitable for locations with a fixed sun angle, such as along the equator. The shape is also easier to mount on flat surfaces. 30 flexible PV modules parallel connected covered a polyester hemispherical shape to produce a single dome with a diameter of 30 cm, 2 m high from the ground. The spherical shape maximizes exposure to sunlight throughout the day, making it suitable for locations with changing sun angles. Solar energy is continuously collected throughout the day, from the early morning rays to the setting sun, presenting a unique opportunity to examine the performance characteristics of hemispherical solar collectors. These innovative designs, with their encompassing shape, boast the potential to optimize energy harvesting efficiency over the day. By comparing the power generated by hemispherical collectors with that of traditional flat-plate collectors, researchers can gain a deeper understanding of the shape and behaviour of the electric power generation curve, revealing

insights into the relative merits of each design. Such comparative analysis can inform the selection of the most suitable solar collector configuration for specific applications, ensuring optimal energy utilization and maximizing the potential of solar energy as a sustainable power source.

3.4.2.4. *Two hemispherical shapes*

The amalgamation of two hemispherical shapes not only serves to optimize energy capture but also introduces a heightened degree of flexibility in positioning. This investigation entails the strategic placement of two hemispheres configured in a dome atop another dome at variable distances, as shown in Fig. 3.11.



Fig. 3.11. Two hemispherical PV module

The primary objective is to systematically explore the influence of the shadow cast by the first hemisphere on the second, with a specific focus on identifying the minimum separation distance required to obviate shadow formation and mitigate its adverse impact on the production of electrical energy. In tandem, this research endeavours to compare these outcomes with those obtained from a single spherical shape equipped with 60 flexible modules. The comparative analysis aims to discern the nuanced factors contributing to the observed distinctions in results between the two shapes, thus facilitating a comprehensive understanding of their respective performance characteristics. Moreover, the inquiry extends beyond the immediate objectives of the study to contemplate the broader implications for urban applications. The investigation prompts consideration of the prospect of generating innovative shapes that are inherently suitable for urban landscapes. This line of inquiry delves into the feasibility of creating structures capable of seamlessly integrating into urban environments, offering not only efficient energy capture but also harmonizing aesthetically with the urban fabric. As urban areas continue to grapple with sustainable energy solutions, these explorations

hold promise in contributing valuable insights towards the development of environmentally conscious and visually appealing technologies for urban energy production.

3.4.2.5. Three hemispherical shapes

The perpetual exposure to sunlight, spanning from early morning to sunset, provides a distinctive opportunity to investigate performance characteristics inherent in three-hemisphere solar collectors. A configuration comprising 90 flexible photovoltaic (PV) modules, connected in parallel and enveloping three polyester hemispherical shapes, is employed to create three interconnected domes arranged in series, as shown in Fig. 3.12. These domes possess a diameter of 30 cm and stand at a height of 2 m from the ground. Distinguished by their novel geometry, these designs hold the potential to enhance the efficiency of energy harvesting throughout the entire diurnal cycle.



Fig. 3.12. Three hemispherical PV module

A comparative assessment of power generation between three-hemisphere and flat-plate collectors can garner valuable insights into the structural and behavioural aspects of the electric power generation curve. This analytical approach contributes to an informed selection process for the optimal solar collector configuration tailored to specific applications, thereby ensuring efficient energy utilization and maximizing the potential of solar energy as a sustainable power source.

Furthermore, the conceptualization of artificial solar trees, emulating the natural morphology of trees, introduces the prospect of seamlessly integrating solar energy production into urban landscapes in a visually appealing and aesthetically pleasing manner. These innovative configurations possess the adaptability to cater to diverse energy requirements, ranging from individual household power to supplying electricity for public spaces. As research and development efforts progress, the anticipated growth in the potential of solar trees positions them as a promising solution for enhancing the aesthetic appeal and sustainability of urban

environments. In essence, artefactual solar trees represent a recent and potentially transformative concept in the realm of solar energy generation and utilization. The harmonious fusion of tree aesthetics with solar panel efficiency enables these structures to seamlessly blend into urban landscapes, offering a clean and renewable energy source.

The measurement period encompassed the months from March through August. In Hungary, the prevailing weather conditions during this period typically feature a preponderance of cloudy days. Consequently, specific days characterized by clear and unobstructed weather conditions were deliberately selected to elucidate the influence of solar irradiance on energy production from spherical geometries. The critical considerations for these spherical and hemispherical configurations include:

a) Distances between solar PV modules: The distances between individual spherical or hemispherical shapes play a crucial role in shading and energy capture. Different spacing can be analysed to find an optimal arrangement.

b) Series and parallel connections: connecting these solar modules can significantly impact the overall voltage, current, and power output. Series connections increase voltage, while parallel connections increase current. The choice of connection method depends on the specific application and system design.

c) Location and arrangement: The location of the spherical or hemispherical modules in relation to other modules and their orientation concerning the sun should be carefully considered. These parameters affect the overall efficiency and energy production throughout the day.

d) The efficiency and performance of spherical solar modules can be affected by the materials used, the quality of the photovoltaic cells, and the temperature (Alktranee et al., 2022). A comprehensive study would examine these factors, environmental conditions, and geographical location to determine the optimal configuration for a given application. The temperature exerts a pronounced influence on energy generation when it exceeds the permissible threshold within operational parameters. Among the primary categories of photovoltaic technology, flexible solar cells demonstrate a relatively minimal susceptibility to temperature-induced variations, with a temperature effect factor of 0.234% for each degree of temperature alteration (Dash and Gupta, 2015). To investigate the impact of temperature on electricity generation and the influence of solar position relative to spherical geometries, sensors have been strategically positioned at various locations on the outer surface of a spherical object designed for temperature measurement in the surrounding environment.

3.4.3. Testing the sunflower PV module

The characteristics of the solar tree and the power generation should be compared with the results with solar modules with dimensions of (1100 × 200) mm flat of the same type of PV module. The cells were connected in the same way to avoid any additional energy losses. The solar tree and the flat module were connected and formed with the same electric circuit, which has six rings connected in parallel, and each ring contains three modules connected in series; thus, the total number of cells was eighteen solar modules.

The PV modules' orientation and tilt angles should be scrutinized to harvest the maximum power from the proposed solar PV tree. The solar modules face south for the northern hemisphere (NH) places. The total incident energy for each surface tilt angle (α) value is computed by adjusting the tilt angle while maintaining surface azimuth angles (γ). The amount of incident energy per day is determined by adding the irradiance at each hourly instant (G). A solar PV module orientation and tilt angle are crucial factors that affect the system output and are thus used in solar thermal panels. A solar PV module ability to absorb energy is determined by its surface azimuth angle (γ) and tilt angle (α), as shown in Fig. 3.13.

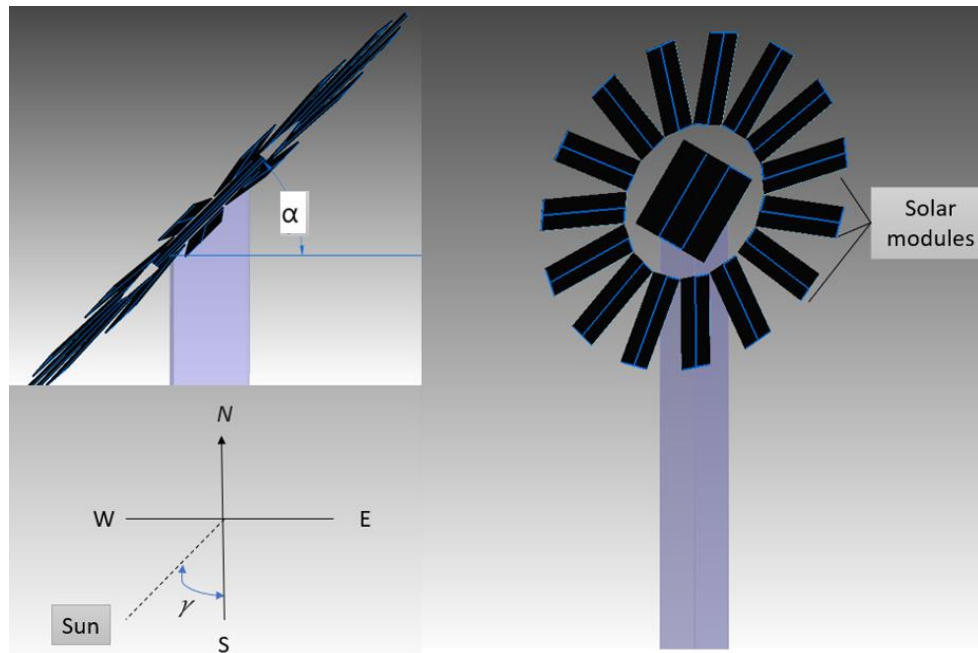

Fig. 3.13. Sunflower PV tree

It is well known that light moves in a straight line and that everything in its path will create a shadow. The solar modules are then positioned with the orientation in mind to reduce shading losses. The solar modules formed the sunflower as one layer to avoid shading each other.

Solar trees are formed in different shapes and forms, and real trees inspire the most (Almadhhachi et al., 2022a). Thus, most trees have weak points due to the formation of shadowy areas on the solar cells when the times of day change or the leaves are tilted at an angle different from the ideal angle for harvesting energy. It should also be noted that the direction of the solar cells may not be the optimum. The shape of the sunflower was chosen as the shape of the solar tree carefully to reduce the losses resulting from shading creation from the branches and other PV modules. It was tested under real conditions to provide accurate, practical data, which allows a clear understanding of the performance of this type of solar tree and the achievement of sustainable development goals. The sun is considered the leading natural energy source that can give actual results for photovoltaics (Hayat et al., 2019), and the part of the solar tree facing the sun with optimum position (best angle and orientation during the day) can harvest more sunlight and conversion into electrical energy. The sun's thermal effect on the solar PV modules will also be calculated to measure the temperature of the solar

module and calculate the temperature of the shaded surface through the solar modules, in addition to measuring the ambient temperature.

A flat PV system (land-based fixed-angle) with the same power capacity is compared to the solar PV tree's output. Three different tilt angles have been tested and measured to find the best tilt angle: Case 1: Tilt angle ($\alpha=45^\circ$); Case 2: Tilt angle ($\alpha=30^\circ$); Case 3: Tilt angle ($\alpha=20^\circ$).

3.5. Calculation methods

The decision-making process regarding the operation of the photovoltaic system depends on several important factors that must be studied in detail to obtain the optimum performance and minor losses. Among these factors is the equipped capacity, which depends primarily on the quality of the solar cells, and the land footprint, which depends on the external appearance of the system.

3.5.1. Power calculation

The following equation can calculate the maximum electrical power generated by the solar PV module (Duffie et al., 1985; Yahyaoui, 2018):

$$\eta_{PV} = \frac{\text{Output Power}}{\text{Input Solar Power}} = \frac{V_{max} I_{max}}{G A} \quad (3.1)$$

Where η_{PV} is the efficiency of the PV module, V_{max} is the maximum working voltage (V), I_{max} is the maximum working current (A), G is the solar irradiance (W/m^2), and A is the PV module surface area (m^2). This equation finds application within conventional planar photovoltaic modules. In assessing the computation methodology for electrical energy yield derived from configurations possessing curvature or sphericity, due consideration must be accorded to solar incidence geometry. This imperative arises due to the Earth's perpetual and uninterrupted rotational motion, engendering alterations in the incident angle of solar radiation upon solar cell surfaces, alongside fluctuations in the effective solar projection area upon the non-planar geometries.

Within the context of spherical geometries, the projection consistently assumes the configuration of a circle, encompassing all azimuthal angles, as dictated by the fundamental attributes intrinsic to spherical forms. This projection adheres to a well-defined, unchanging diameter throughout a complete rotation of 360 degrees. Conversely, in the context of the conventional Cartesian coordinate system delineated by the three orthogonal axes (x, y, and z), applying Eq. 3.1 is comparatively more straightforward for rectilinear structures. This ease arises since, in these cases, the entire surface area is invariably subjected to direct solar irradiance across diurnal cycles. However, disparities in solar incidence angles introduce heightened intricacies when applying Eq. 3.1 to spherical configurations. The complexities emanate from the augmented variability in the angles of solar impingement. This is due to the dynamic curvature of the spherical shape, resulting in diverse portions of the surface encountering both direct and indirect sunlight exposures. Consequently, the quantification of electrical energy production becomes more intricate for spherical shapes, necessitating a refined analysis.

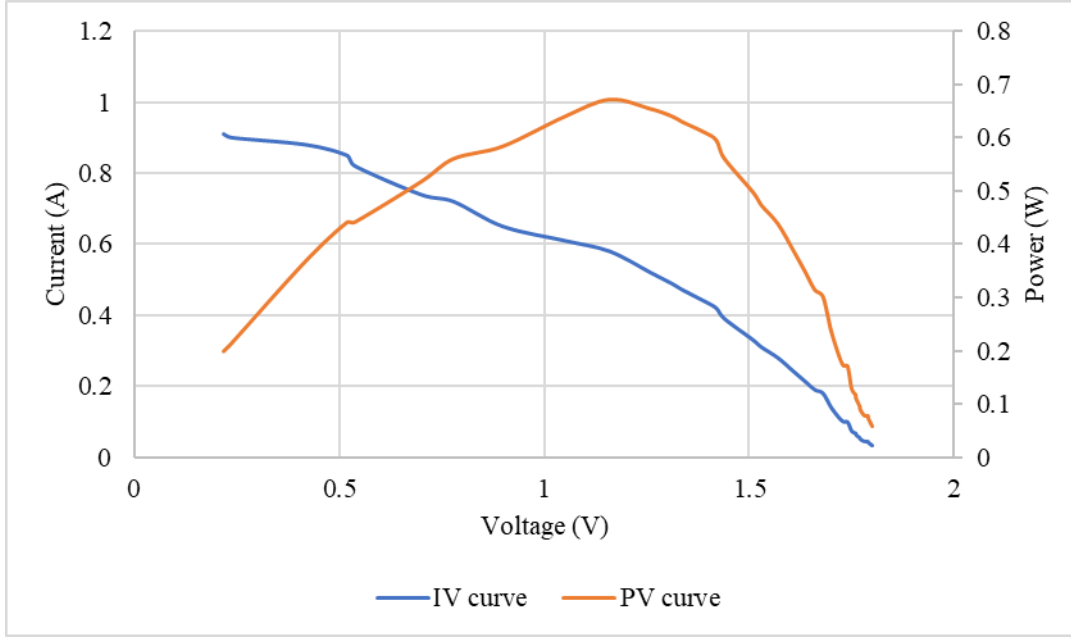

Fig. 3.14. IV characteristic curve of the hemispherical PV module

The incidence angle of solar radiation directly influences the production of electrical energy. As illustrated in Fig. 3.14, we observe a distinct behaviour in the IV characteristic curve for the hemispherical configuration. Consequently, this behaviour diverges appreciably from the IV characteristic curve for an individual flexible module of an identical solar cell type without accounting for losses incurred during the interconnection of solar cells within the hemispherical structure. It is important to note that the IV characteristic curve exhibited a hemispherical configuration when placed horizontally, with a concurrent global solar radiation of 880 W/m^2 . Each PV module receives solar radiation in different amounts since the PV module has a different position on the hemispherical shape. Meanwhile, all PV modules continue to generate electricity at the same time.

The maximum power for the spherical PV module = the power from the direct projection area - the power from the rest of the surface area. The PV modules will consume the power from the others if they generate less power than others. The following equation will calculate the power for the spherical configuration:

$$P_m = \eta_{PV} A_c G - \eta_{PV} 3 A_c, \quad (3.2)$$

where P_m is the maximum power (W), A_c is the projection circle area (m^2), and G_d is the diffused solar irradiance (W/m^2). The outer surface area of any spherical shape = $4 \pi r^2 = 4$ circle area, the sunlight will fall on the circular projection area of the spherical shape, and the rest of the outer surface continues harvesting the diffused solar irradiance. The diffused radiation can be calculated from the following equation (Duffie et al., 1985):

$$\frac{G_d}{G} = 0.271 - 0.294 \tau_b, \quad (3.3)$$

where τ_b is the atmospheric transmittance, which can be calculated as follows (Duffie et al., 1985):

3. Materials and methods

$$\tau_b = a_0 + a_1 \exp\left(\frac{-K}{\cos\alpha_z}\right). \quad (3.4)$$

The constants K , a_0 and a_1 can be found by the correction factors $r_0 = a_0/a_0^*$, $r_1 = a_1/a_1^*$ and $r_k = K/K^*$, according to the climate type (Duffie et al., 1985) $r_0 = 0.97$, $r_1 = 0.99$, $r_k = 1.02$ and K^* , a_0^* and a_1^* can be found by :

$$a_0^* = 0.4237 - 0.00821(6 - A_{alt})^2, \quad (3.5)$$

$$a_1^* = 0.5055 - 0.00595(6.5 - A_{alt})^2, \quad (3.6)$$

$$K^* = 0.2711 - 0.01858(2.5 - A_{alt})^2, \quad (3.7)$$

where A_{alt} is the altitude of the PV module in kilometres. The power generated for the spherical PV configurations can be calculated by Eqs. 3.2 and 3.3, as shown in Table 3.5.

Table 3.5. The calculated and measured power for the spherical PV configuration

PV configuration	Calculated Power (W)	Measured power (W)	Difference (%)
Single sphere	2.41	2.02	16
Three spheres	4.09	3.13	23

To enhance result validity and address the scarcity of research on spherical PV shapes, all experiments in this research were systematically replicated multiple times. The outcomes exhibited high consistency, with a change rate of less than 7% observed under similar weather conditions (a consistent and comparable set of atmospheric parameters and meteorological variables prevailing during the days of measurement. These parameters encompass, but are not limited to, temperature, humidity, wind speed, atmospheric pressure, and precipitation.), as depicted in Fig. 3.15.

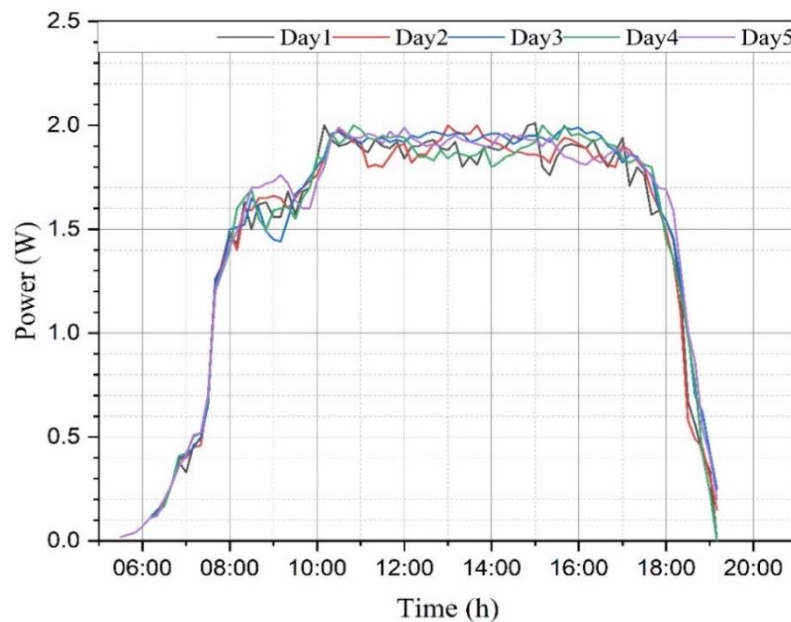

Fig. 3.15. Spherical PV module power during multiple days

A hemispherical PV module presents an interesting case for modelling power output because it combines aspects of both flat and spherical modules. Like the spherical module, the hemispherical shape means that different parts of the module will receive different amounts of sunlight depending on their orientation relative to the sun. To estimate the power output of a hemispherical PV module, an equation similar to the one suggested for the spherical module could be used with more complexity but modified to account for the fact that only half of a sphere is being dealt with (Eicker, 2005):

$$P_m = \eta_{PV} \int G(\alpha, \gamma) \cos(\alpha) dA, \quad (3.8)$$

where: $G(\alpha, \gamma)$ is the solar irradiance (W/m^2) at a given point on the hemisphere as a function of the polar (α) and azimuthal (γ) angles. $\cos(\alpha)$ accounts for the angle of incidence of the sunlight. dA is the differential area element on the hemisphere. Integration over the surface of the hemisphere would be performed to account for the varying irradiance across the module. The $\cos(\alpha)\cos(\gamma)$ term would ensure that areas of the module that are not directly facing the sun contribute less to the total power output, consistent with how photovoltaic cells behave.

3.5.2. Footprint calculation

The land footprint plays a pivotal role in the context of photovoltaic technology deployment, with substantial solar installations conventionally sited in arid terrains or peri-urban regions as a response to the exorbitant costs associated with land acquisition in more densely populated areas. A promising remedy to this quandary is the implementation of solar tree structures, which exhibit a markedly reduced terrestrial footprint for photovoltaic systems, resulting in an impressive 90% reduction in land utilisation when juxtaposed with conventional counterparts (Almadhhachi et al., 2022a).

To determine the land footprint of an individual hemisphere, one may calculate it by ascertaining the aggregate area of a single flexible module and subsequently multiplying this area by the total number of modules comprising the hemispherical structure. This measure can then be compared to conventional systems for reference.

Solar tracker hemispherical PV module has a diameter = 0.25 m and surface area = 0.098 m^2 . According to the PV specification in Table 3.3, the six PV module area = 0.0394 m^2 . the footprint reduction = 40.2%.

As delineated in Table 3.4, the surface area occupied by a single flexible PV module equals 0.0033 m^2 , and the number of these modules required to cover the hemispherical configuration amounts to 30. Consequently, the total surface area of these 30 flexible PV modules is up to 0.099 m^2 . The land footprint of an individual hemispherical structure can be calculated as the area of a circle with a diameter of 0.3 m, resulting in a value of 0.1414 m^2 . Therefore, the ratio of the land footprint of an individual hemispherical structure compared to conventional systems stands at 0.7, signifying a reduction in footprint area by 30% (excluding the need for a stand to carry the hemispherical structure). Consequently, the unoccupied section of the hemispherical shape, not covered by solar cells, measures 0.0424 m^2 . This covered area constitutes 70% of the total surface area of the spherical shape. Therefore, based on this calculation, the surface area of the spherical object is 0.2828 m^2 , with the section covered by the flexible solar modules spanning 0.198 m^2 .

The spherical configuration comprises 60 flexible PV modules. Calculating the land footprint of these flexible PV modules within conventional flat systems necessitates an area of 0.198 m². In this research, the spherical structures are supported by a wooden pole measuring 10 cm by 10 cm. As a result, the ratio of the land footprint of the spherical structures compared to conventional systems stands at 0.05, offering a substantial 95% reduction in land area usage. The solar tree, composed of three spherical structures mounted on a single wooden stand, requires a mere 1.6% of the land space occupied by traditional arrays, resulting in a remarkable 98.4% land footprint savings.

3.6. Temperature measurements

To examine thermal imagery in solar modules, deploying temperature sensors strategically placed at various locations within a single solar module, specifically on the right, left, middle, top, and bottom, is essential. This multidirectional placement aims to construct a comprehensive representation of temperature distribution and elucidate the impact of the sun's movement from dawn to sunset. The temperature sensors were fixed to PV modules without an insulation layer avoiding any unnecessary losses in measurements and any other environmental disturbances. Moreover, the sensors have a reasonably small size (1 mm diameter), therefore they can touch the PV module surface directly. Because of their very small surfaces, low temperature gradient and heat transfer coefficient toward the air, it is assumed that the measurements have not been significantly affected by the environmental air temperature. The control measurements of the PV module temperatures have been justified by infrared meters.

In the case of flat-shaped solar modules, sensors of the NTC type are positioned at distinct points, encompassing the far right, far left, middle, top, and bottom, as shown in Fig. 3.16. The readings from these sensors are systematically recorded and connected to a data logger for subsequent analysis. Notably, during the morning, the temperature recorded on the right surpassed that on the left, with a subsequent reversal observed in the afternoon. The temperature differential between the right and left sides amounted to three degrees. Interestingly, the middle temperature emerged as the highest among all recorded temperatures during the experimental periods. Additionally, the middle temperature registered approximately five degrees higher than the right-side temperature. These observations provide valuable insights into the dynamic thermal behaviour of solar modules throughout the day.

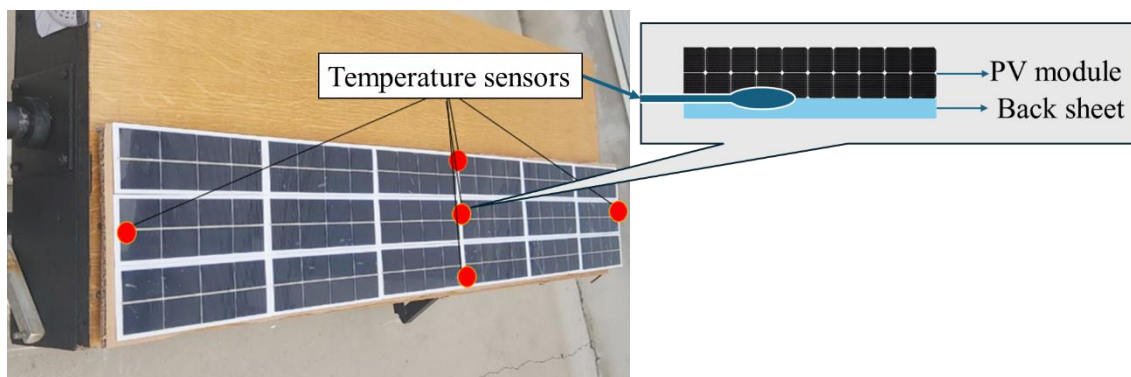

Fig. 3.16. Temperature sensors positions in a flat shape

Within the context of spherical configurations, a meticulous approach to thermal analysis was undertaken by situating five temperature sensors strategically along the edges of the sphere. This methodological placement aimed to provide a nuanced thermal image, capturing the temperature dynamics across various sections of the spherical shape, as shown in Fig. 3.17. The results illuminated a clear and expected pattern: the highest temperatures were distinctly observed in the region directly facing the incoming sunlight. Conversely, the lowest temperatures manifested in the shaded area, precisely on the side opposite to the one exposed to direct sunlight.

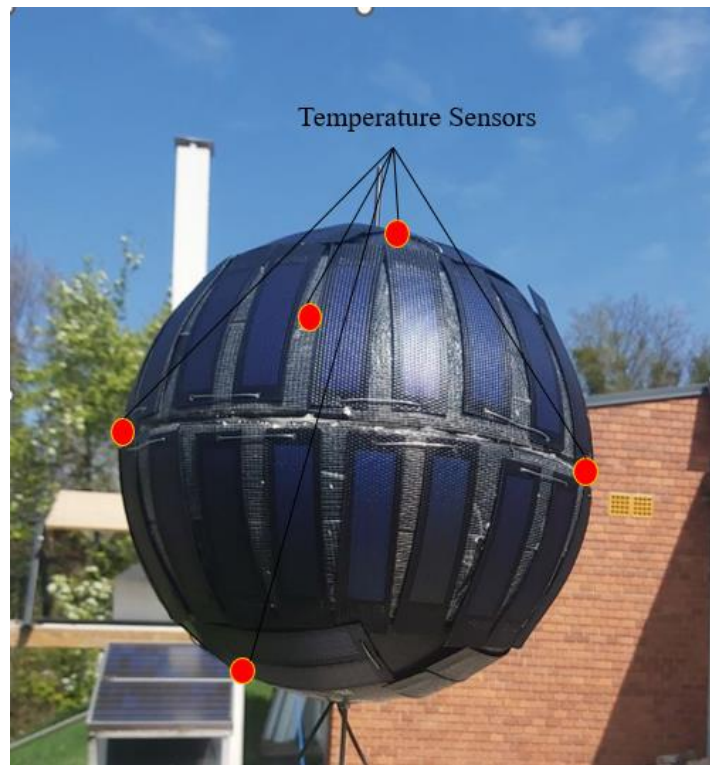

Fig. 3.17. Temperature sensors positions in a spherical shape

This thermal mapping corroborates established principles of solar heat absorption and accentuates the three-dimensional nature of temperature variations within spherical geometries. The juxtaposition of the warmer and cooler zones elucidates the intricate interplay between solar exposure and temperature differentials across the sphere's curved surface.

Multiple temperature sensors were strategically placed across the surface to capture a comprehensive thermal image in investigating hemispherical shapes. The findings revealed a distinctive temperature distribution pattern, wherein the highest temperature corresponded to the region directly exposed to sunlight, and the lowest temperature was recorded on the side opposite to the direction of direct sunlight. Notably, a temperature differential of three degrees was observed between the edges of the solar projection, with an additional five-degree difference extending toward the centre of the solar projection—representing the highest temperature recorded within the hemispherical shape. Furthermore, it was observed that the thermal imagery of both spherical and hemispherical shapes dynamically altered with variations in the angle of incidence of sunlight. The highest temperature was consistently found perpendicular to the sunlight falling on the spherical shape. In contrast, the lowest temperature consistently manifested on the side opposite to this point of maximum solar exposure. These observations underscore the intricate relationship between solar incidence angles and the

resulting thermal patterns, contributing valuable insights into the nuanced behaviour of spherical and hemispherical solar configurations under varying sunlight conditions.

Five temperature sensors were strategically positioned across the sunflowers to generate a comprehensive thermal image of the sunflower-shaped solar configuration, as shown in Fig. 3.18. These sensors were distributed to capture temperature readings at various locations, including one at the centre and the remaining distributed along the edges, including the initiation point of the branching in the solar modules. The temperature discrepancies observed were substantial, exceeding ten degrees, particularly between the central region and the remote edges of the sunflower. These findings underscore the significant impact of sunlight exposure on the electrical power generation capabilities of the sunflower-shaped solar modules. The temperature emerged as a pivotal factor contributing to this discernible difference, emphasizing the intricate relationship between solar incidence, thermal variations, and the resultant electrical power output within the innovative sunflower configuration.

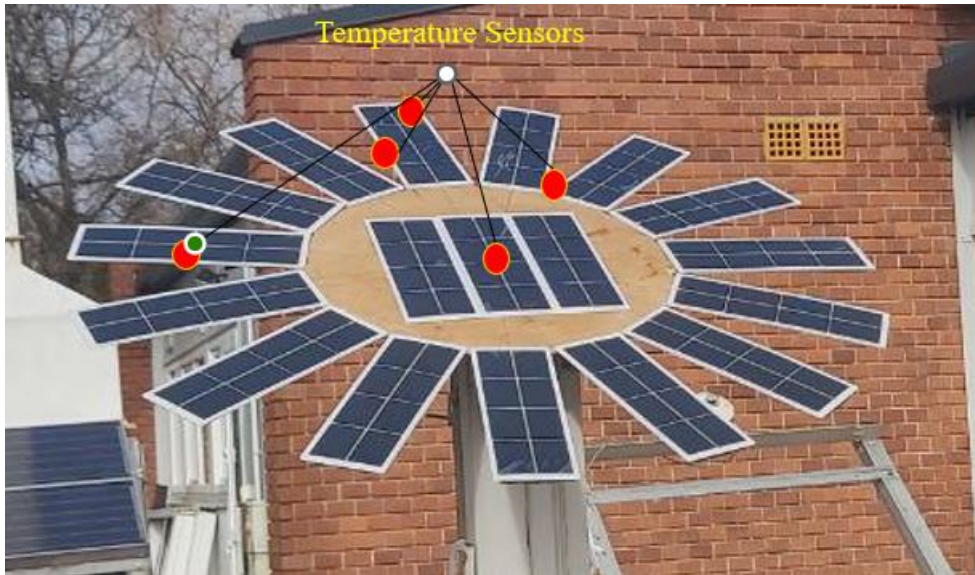

Fig. 3.18. Temperature sensors positions in the sunflower

3.7. Uncertainty analysis

This section discusses the measurement uncertainty, and the target parameter in this research is the electricity power. It may be calculated from the voltage and the current, as suggested by Holman (Holman, 2018), considering a collection of measurements where each measurement's uncertainty can be stated using the same odds. The desired outcome of the tests is then calculated using these measurements. Based on the errors in the primary measurements, we could estimate the uncertainty in the estimated result according to Eq. 3.9 as follows:

$$w_R = \left[\left(\frac{\partial R}{\partial x_1} w_1 \right)^2 + \left(\frac{\partial R}{\partial x_2} w_2 \right)^2 + \dots + \left(\frac{\partial R}{\partial x_n} w_n \right)^2 \right]^{1/2}, \quad (3.9)$$

where R is the parameter required to calculate its uncertainty (a function of a measured variable x_1 , x_2 and x_n). w_R is the result's uncertainty, w_1 , w_2 , and w_n are uncertainties of the independent variables. According to the calculation results, the uncertainty for the electrical power is equal to $\pm 0.943 \%$.

4. RESULTS

The performance of the new configurations of the PV modules has been investigated and compared with the conventional PV system. The daily power and the outcomes can be categorized based on the stages of the conducted tests into three fundamental cases, as delineated below.

4.1. Solar tracker hemispherical PV module

Flexible solar modules in the selected models show practical results that can be used to analyse the design of large electricity generating systems and understand the impact of curved modules and new forms. The flat modules were compared with hemispherical ones with more than one mode to show the effect of the inclination angle on electricity generation and the impact of the number of modules.

4.1.1. Inclination angle of 45° for the flat and hemispherical PV modules

Inclined solar modules can capture solar irradiance more efficiently, capturing more perpendicular light than inclined light. Fig. 4.1 compares the power produced by twelve flat flexible solar modules with two hemispherical modules with the same number of PV modules at the same inclination angle. The results demonstrate a convergence in the electricity production quantities.

Moreover, the shape of the output power line for the hemispherical module was like the behaviour of the solar tracking system. This result is similar to the simulation study of Piotrowski and Farret (2022), who found that the solar tracking topology generating curve maintained its highest values in the early morning and late afternoon of each day along the simulation duration. At midday, the two systems generated almost the same amount of energy. However, the flat PV system harvested more solar radiation and produced more electricity than the curved system by 0.1% - 2.5% before sunset because the flat shape has more direct area towards the sun. As the sunset occurs, the hemisphere shape produces more electricity than the flat shape by about 0.1%- 4% since the curved shape has more area towards the sun.

However, the flat PV system showed a better generation in the afternoon since the shadow started in some parts of the hemispherical shape due to sunset, besides the shading effect of one hemispherical module to another. Finally, the generated power dropped in the flat system, while the hemispherical system still generates electricity. The difference in power production between the flat modules with the hemisphere from midday to sunset was about 0.8 W, representing 1.8% of the experiment time production.

4. Results

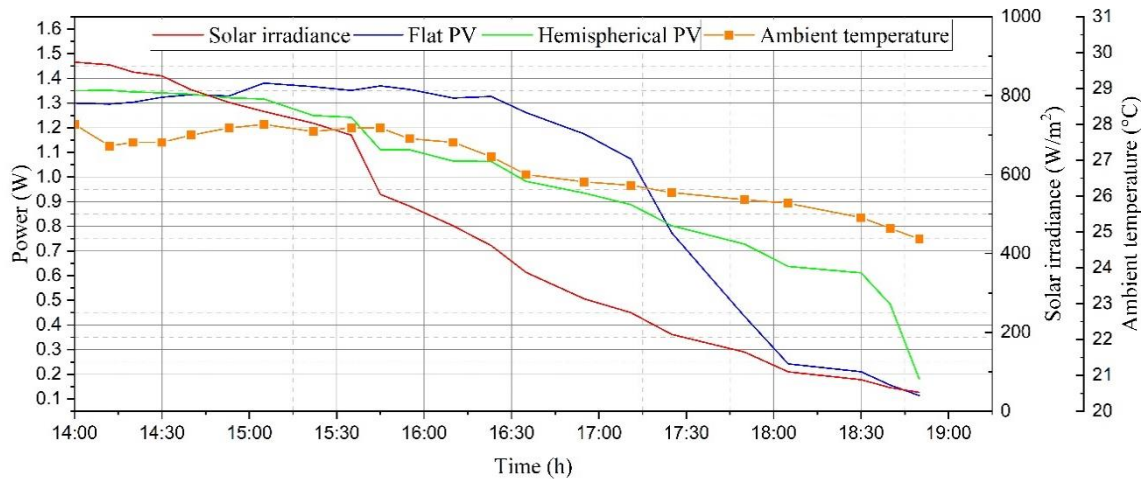

Fig. 4.1. Power generation from twelve PV modules titled 45°

The hemispherical-shaped module continued to produce electricity at the solar irradiance below 250 W/m^2 . At the same time, the flat PV was affected, and the power generation was dropped due to low solar irradiance and hour angle (ω) more significant than 82.5° (the hour angle at sunset was between 120° - 125°). Since ω can be calculated (Duffie et al., 1985): "the angular displacement of the sun east or west of the local meridian due to rotation of the earth on its axis at 15° per hour; morning negative, afternoon positive".

In contrast, the overall production from a series of two hemispherical shape modules was less than that of the flat shape due to the shadow formed in the late afternoon. The shade can be avoided by changing each hemispherical position and increasing the distance between them. Since the ratio between the radius of the hemispherical shape to the distance between the two hemispheres, as chosen in this experiment, is 250 mm and 200 mm, respectively, it is not enough to avoid shadow generation on the second shape since the shaded will start at (ω) = 90° .

The single hemispherical shape with six thin-film solar modules showed greater electrical energy production than the flat PV module because there is enough perpendicular PV area along the solar path. Fig. 4.2 shows the output electrical power during the afternoon in which the hemispherical shape PV system produced more power than the flat PV shape system by 6.7 % during the experiment. The output power behaviour from the single hemispherical module can be compared to the power output from the PV system with solar tracking technology. This finding is similar to that of Fathabadi (2016), where it was also made similar observations in his experimental study, where the solar tracking system was used to harvest the maximum solar power by following the solar bath during the daily time.

Solar PV cells are susceptible to adverse impacts from elevated temperatures, resulting in an unfavourable influence on their electrical energy generation capacity. Each distinct category of solar cell possesses a thermal coefficient, a parameter integrated into the energy generation equations. Minimizing the thermal coefficient has particular interest to consumers, especially those residing in hot regions. Conspicuously, flexible solar cells exhibit a distinctive strength

in this regard, as they manifest the lowest thermal effect coefficient among various solar cell types, including polycrystalline and monocrystalline variants.

In the context of designing solar energy systems, it is imperative to consider the prevailing temperature conditions within a given geographic region. This consideration guides the selection of the most suitable solar cell type for optimal performance. In the context of the present practical research endeavour, the ambient air temperature fluctuated within a range of 23 °C to 26 °C. This temperature range is conducive for conducting rigorous investigations and evaluating solar systems with minimal perturbation to energy production outcomes.

According to Dash and Gupta, the thin-film PV module had a low-temperature coefficient (about 0.234%/°C) (Dash and Gupta, 2015). The maximum flat PV module temperature is raised to 62 °C compared to 58 °C by the proposed hemispherical shape. The solar cells lose the heating by convection heat transfer due to air going between solar modules.

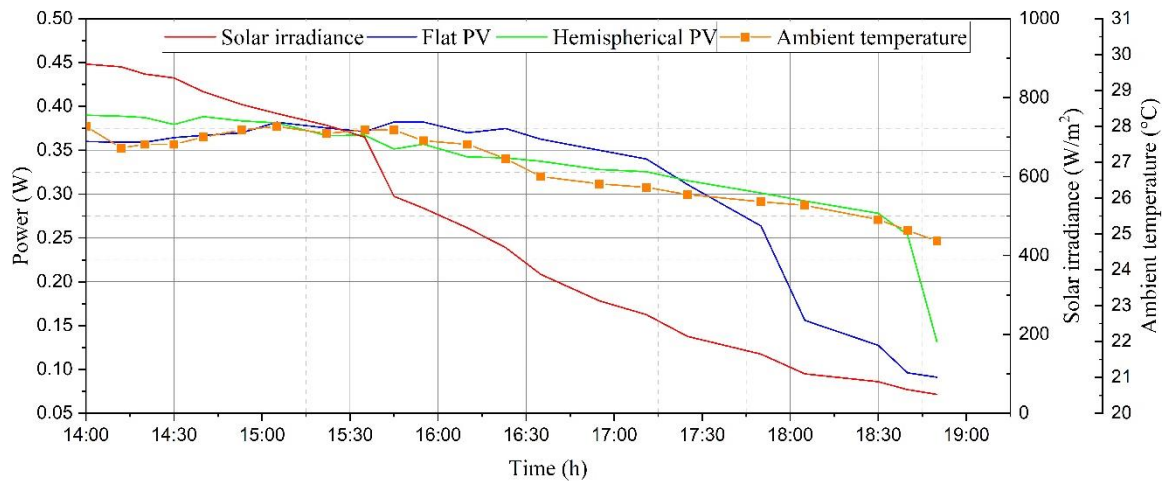

Fig. 4.2. Power generation from six PV modules titled of 45°

The projection area of the sunlight on the hemispherical PV module is circular at all the solar paths during the day because the module is 45° inclined, which leads to capturing the maximum sunlight to produce the electricity. The electricity productivity for each shape converges at a tilt angle of 45° when (ω) less than 82.5°, at the solar irradiance of 250 W/m², the hemispherical shape produces more power than the flat shape by 1% - 6%.

Figs. 4.1 and 4.2, showed that the intersection points between the two power lines of hemispherical and flat-shaped PV modules occurred at the same time at 17:45. At this time, the sun started to change its direction, and the power of the flat PV system dropped. However, the hemispherical system continued generating power till the late afternoon.

4.1.2. Analysis of the hemispherical and flat PV modules with horizontal position

Many applications, such as electric cars, rooftops, agriculture greenhouses, and parking, could utilize the horizontal PV system. Hemispherical shapes can also provide spaces under the solar modules to be exploited in various fields.

The surface area of a single flat PV module equals 0.01 m^2 ; for a six-flat PV module, it becomes 0.06 m^2 . The surface area of a hemispherical PV module can be calculated as the surface area of a spherical shape divided by 2, and it will be 0.049 m^2 .

As indicated in Fig. 4.3, the hemispherical module showed less power generation than the flat PV system. The flat system contained twelve PV modules, producing more than the two hemispherical PV modules by 6.95 W and 23% during the experiment. The PV system is affected by the incidence angle of sunlight. This is the main reason describing the lower power generated from the horizontal PV system. In addition, the shadow caused by the horizontal hemispherical PV system (another side of the hemisphere shape) has decreased the generated electricity more than the flat PV system (no dead zone in this system).

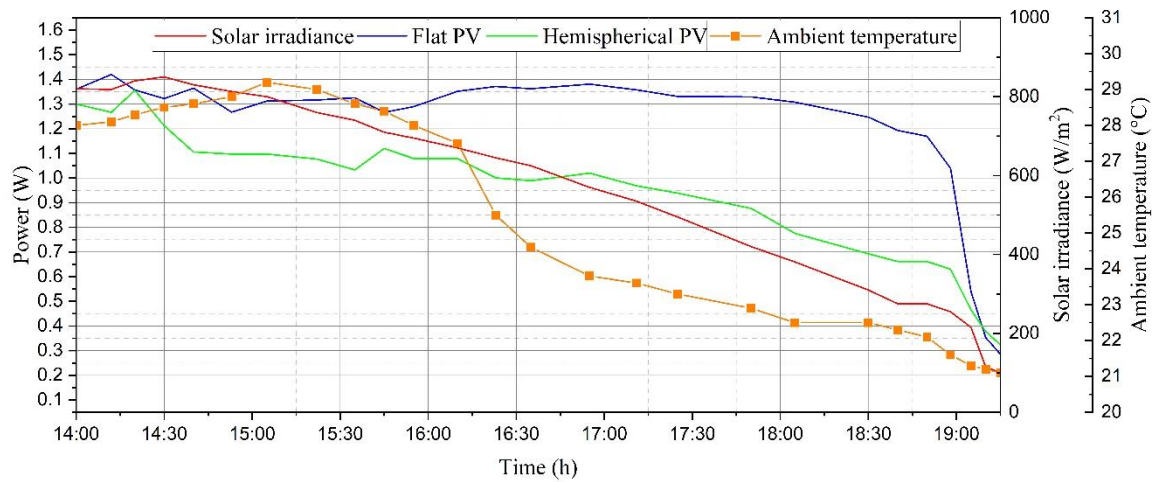

Fig. 4.3. Power generation from horizontally tilted twelve PV modules

In the horizontal PV system, the flat PV power line is smooth, and the system continues to generate electricity in the late afternoon because the sunlight is always inclined toward the PV surface without a dead zone until sunset.

The horizontal level shows different results compared with the inclined PV system. Fig. 4.4, shows that the power produced from the flat system is more than the hemispherical shape by 0.96 W, equivalent to 11.4% of the experiment time production. At the horizontal plane, the flat shape continued producing electricity due to diffusion and scattered solar radiation in the late afternoon without shading generated at any point in the surface area of the flat shape. Figs.4.3 and 4.4, show the power productivity at (ω) less than 105° .

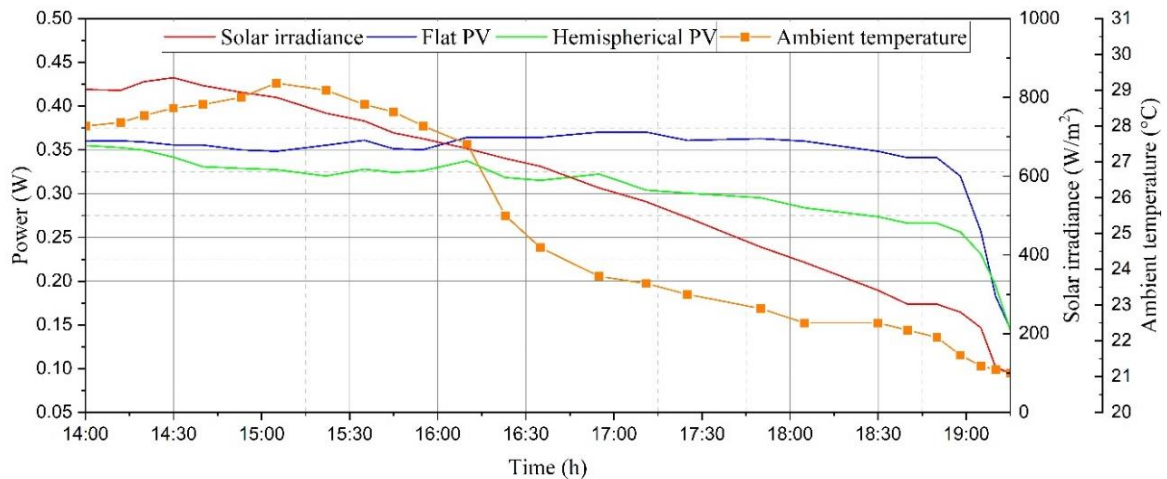

Fig. 4.4. Power generation from horizontally tilted six PV modules

There is no intersection point between the power line for the flat and the hemispherical PV module in the horizontal mode. This is because the flat PV module produced more power than the hemispherical PV module for the same surface area of solar cells. However, at least the footprint is still beneficial and adds aesthetic to the final system shape. The solar PV module was affected by solar radiation immediately. To improve harvesting efficiency, it is essential to cover the surface area of the horizontally tilted hemispherical shape completely with solar cells. This ensures the absorption of sunlight falling on the hemispherical shape and maximizes power production. Covering the entire surface area facing the sun with solar cells is recommended to maximize the potential benefits of the curved shape.

The sun moves across the sky differently in different parts of the world and at different times of the year due to the earth's natural tilt and orbit around the sun. The vertical angle at which the photovoltaic cells should be set for maximum energy production from sunlight hitting the surface depends on the solar installation's geographic latitude. The inclination of solar modules also plays a role in mitigating the effects of various environmental factors, such as dust, sand, and dirt accumulation in arid, polluted, or desert regions. These substances can obstruct sunlight and hinder the efficiency of energy conversion. Moreover, a steeper tilt angle can effectively minimize snow and ice accumulation on the module surfaces by facilitating the sliding-off of such precipitation.

To obtain the most significant capacity in the winter, the angle of inclination should be approximately 15 degrees greater than the optimal angle during the year, while the angle should be less than 15 degrees to obtain the greatest capacity in the summer. Solar modules are often installed according to the optimal inclination angle, which is the angle that secures the generation of the largest capacity of the modules during the year. It is worth noting that this angle is approximately equal to the latitude value of the area where the solar modules will be installed.

All previous figures show that any change in solar radiation led to changes in the power line. As a result, the power production of the hemispherical shape module will be as high as 95% and 105% for the two hemispheres and single hemispherical shape, respectively, compared

with the flat PV module considering a 45° inclination angle. However, the horizontal mode of the PV system has different results. The two and single hemispherical module power production produces less power by 23% and 11.4%, respectively than the flat PV module.

4.2. Spherical and hemispherical PV module

The spherical PV configurations commence the process of solar energy harvesting from the early morning until late afternoon, as they are not reliant on the peak hours typically associated with generating electrical energy between 10:00 a.m. and 4:00 p.m., as indicated by literature (Wang et al., 2020). This is facilitated by adequate spatial resources for energy acquisition afforded by the spherical configurations, constituting a primary point of divergence from established conventional photovoltaic technology systems.

Elevated temperatures notably influence the performance of solar PV modules (Bayrak et al., 2019). However, the flexible photovoltaic cells employed in this research exhibit reduced sensitivity to temperature fluctuations compared to monocrystalline and polycrystalline cells. In Hungary, the summer temperatures typically range between 26-28 °C, which falls within the range of acceptable operating temperatures for photovoltaic systems. Consequently, the impact of temperature on the efficiency of solar modules is minimal in this context.

4.2.1. Single spherical PV module

Spherical configurations persist in collecting solar energy and the subsequent generation of electrical power, commencing in the early morning and extending throughout the day. Fig. 4.5 illustrates the electrical power curve associated with solar radiation incident upon a spherical structure enveloped by photovoltaic modules. This curve exhibits a behaviour akin to that of a solar tracking system. This similarity can be attributed to the consistent cross-sectional surface area, which maintains a circular configuration throughout the day for spherical shapes.

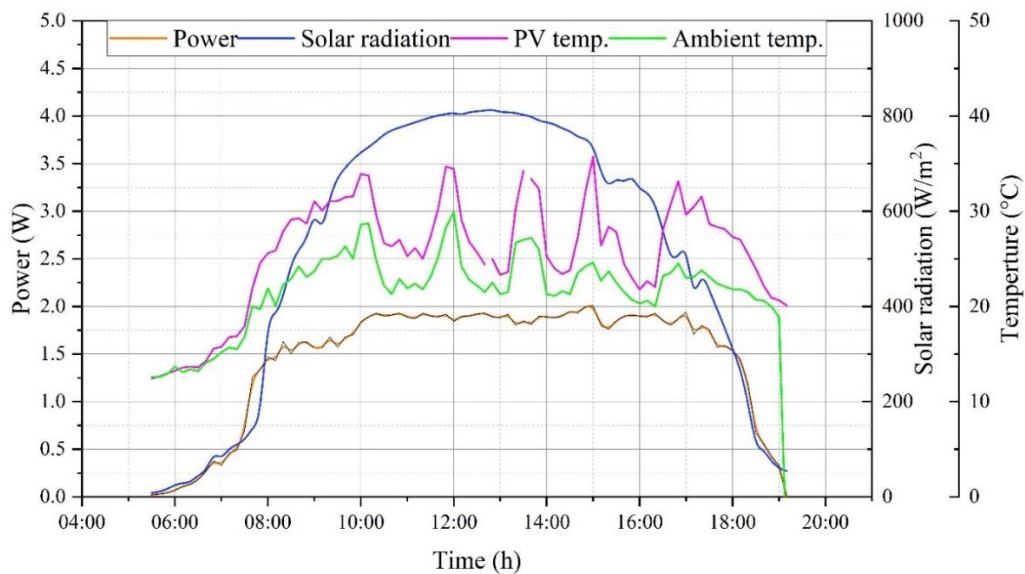

Fig. 4.5. The power generated from a single spherical shape

The difference between the measured maximum power (2.02 W) and the calculated power (2.41 W) is approximately 16%. This difference could be considered acceptable in some contexts, especially given the complexity of measuring and modelling the performance of a spherical PV module.

At 8:00 a.m., the generation amount was 73.6% of the highest generation recorded for that day, and the generation amount at 6:00 p.m. was 74% of the highest recorded generation amount, which records a generation time of up to 10 hours per day in Hungary.

Solar modules on the opposite side of sunlight have a negative effect on the total power generation due to their spherical shape. They depend on reflected and scattered sunlight only, and the temperature of these modules is the lowest temperature among other solar modules.

The surface of the sphere has a large variation in temperature, with the highest temperature recorded at 50.2 °C for a solar module corresponding to direct sunlight, compared to 27 °C for the air temperature. As for the rest of the solar modules, they were variable, and there was no equality between any two solar modules at the same time due to the changing angle of incidence of sunlight on the spherical surface. The average temperature was 34.2 °C, which is the highest average temperature during the day.

The average temperature experienced by the solar modules closely approximates the ambient temperature of the surrounding environment, owing to the thermal equilibration of the spherical shape's surface. Additionally, the consistent presence of wind across the extensive surface area of the spherical configuration provides effective cooling for the solar modules, thereby preventing the occurrence of elevated temperatures, particularly considering the substantial surface area available for heat dissipation.

4.2.2. Three spherical PV modules

The three spherical configurations collectively form a simplified model resembling a solar tree inspired by a grape structure, facilitating the examination of the influence of interconnected spherical shapes on both the environment and energy production. Solar trees represent a valuable addition to urban landscapes as they draw inspiration from nature (Almadhhachi et al., 2023), harmoniously blending the principles of nature with technology to generate electrical energy. They leave a positive visual impact while reducing the terrestrial footprint, which is a crucial factor in calculating the cost-effectiveness of solar systems.

By offering an extensive surface area relative to their land footprint, solar trees effectively contribute to decreasing surface temperatures through enhanced airflow, thereby promoting improved heat dissipation and the sustained efficiency of the solar modules. The output of three spherical configurations yielded a power output of 3.13 W, juxtaposed against a theoretically computed value of 4.09 W, resulting in an appreciable variance of 23%. This noticeable difference can be explained by the existence of shadow resulting from the superimposed spherical shapes. Fig. 4.6 presents data illustrating the energy production, temperatures, and solar radiation for three spherical clusters of solar modules. The power curve takes an almost square shape, which explains the stability of power generation throughout the day if the weather is clear and there is no shadow on the solar tree. It also turns out that the amount of generation

is reduced by 50% compared to the single spherical shape due to the formation of the shadow balls on each other.

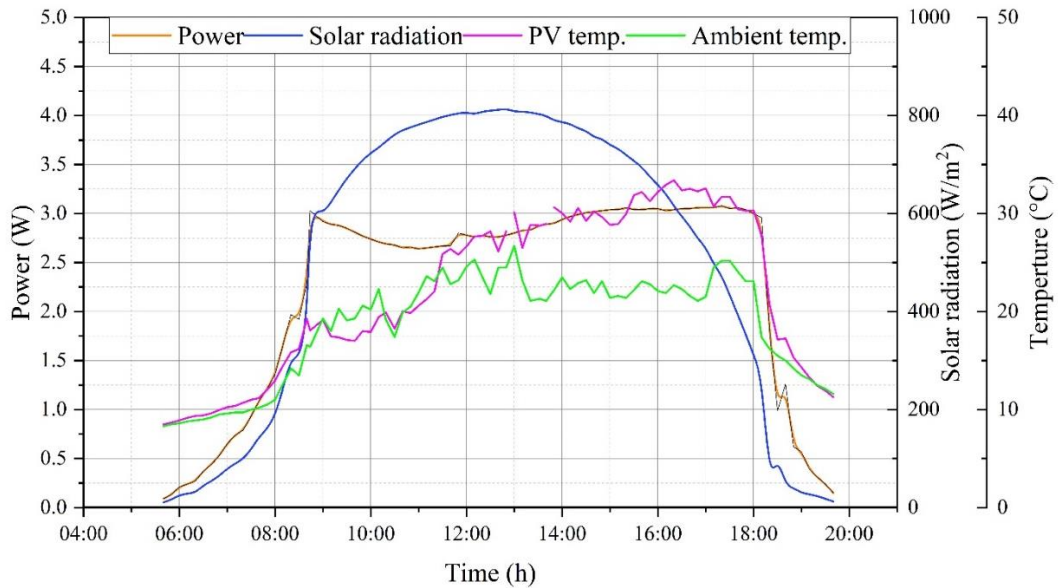

Fig. 4.6. The power generated from three spherical shapes

There is great importance in how to form and assemble the solar balls and calculate the distances between them to avoid forming shadows on each other, as depicted in Fig. 4.7. Two spherical PV configurations are aligned along a shared axis with a separation distance of 40 cm. At the same time, the third sphere is positioned on an axis parallel to the first, and the distance between the two vertical axes is 55 cm. Notably, the centre of the third sphere is strategically situated midway between the two spheres on the first axis, thereby mitigating the formation of shadows to the greatest extent possible, thus optimizing the collection of solar energy. The three spherical configurations collectively form a simplified model resembling a grapevine structure, facilitating the examination of the influence of interconnected spherical shapes on both the environment and energy production.



Fig. 4.7. Solar tree from three spherical shapes

Spherical PV modules initiate electrical energy generation at dawn each day and maintain a nearly constant energy production rate throughout the daylight hours until sunset. The area directly exposed to sunlight experiences more significant temperature increases than the remaining external surface of the spherical structures. This results in the continuous alteration of heat concentration areas in tandem with the sun's movement, aiding in the consistent dispersal of heat and the cooling of solar modules, particularly when complemented by wind-induced air movement.

The extent of distortion, as a percentage, exhibits an upward trajectory as the inter-ball distances decrease, subsequently leading to a reduction in the energy output of the solar tree configurations. Generating energy from solar trees is one of its main goals, in addition to enhancing aesthetics and increasing environmental awareness within urban areas. Therefore, it requires careful study to decide whether the primary intention is to enhance the visual appeal of urban areas or generate energy. On this basis, priorities can be given.

Conversely, if the principal focus is on energy generation, then optimizing the inter-ball distances to maximize solar energy harvest would be paramount, even if it involves some compromise on the aesthetic front. Striking a balance between aesthetics and energy efficiency is essential to effectively align the solar tree's design with its intended purpose.

4.2.3. Single hemispherical PV module

Hemispherical configurations display a notably reduced land footprint and its implications on electrical power generation, as clarified in Fig. 4.8; this figure illustrates power generation, solar radiation, air temperature, and the average temperature of the solar PV modules, showcasing a remarkable degree of stability and consistency in power generation. The hemispherical shape recorded an amount of energy higher than the spherical shape by 32%, compared to a similar number of solar modules used in practical experiments, because of losses in the opposite directions of sunlight.

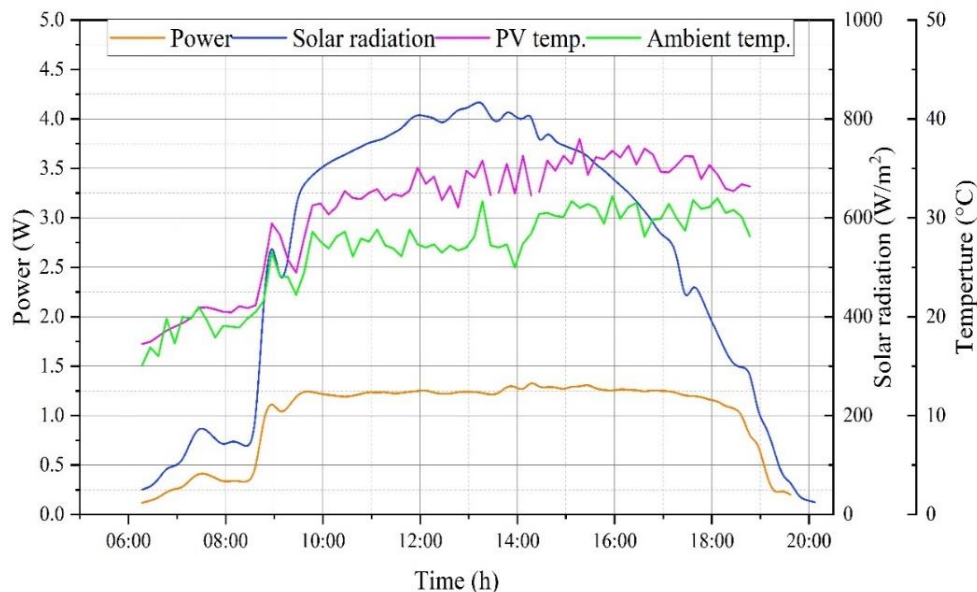

Fig. 4.8, the power generated from a single hemispherical shape

The behaviour of the stability of the generating power curve is particularly evident from morning until sunset, when the solar radiation curve remains constant, and the weather conditions are clear. During these periods, the behaviour of power generation closely parallels that of solar modules employing solar tracking mechanisms. However, one noteworthy challenge lies in effectively addressing solar cells on the side opposite to the incident sunlight, as this arrangement can hinder efficient electrical power generation. To address this challenge, a strategic solution involves the distribution of flexible modules symmetrically across the outer surface of the hemispherical shape around its vertical axis. This arrangement accounts for the observed stability in energy generation throughout the day. Simultaneously, the spaces between the flexible cells serve the dual purpose of reducing and dissipating the temperature within the solar modules. This temperature control, coupled with the moderate air temperature ranging from 25-30 °C during daylight hours, falls within the operational temperature range and constitutes a fundamental factor in maintaining the efficiency of the solar modules utilized in this research.

4.2.4. Two hemispherical PV modules

The two hemispherical configurations of solar modules were interconnected along a single axis in parallel; the ensuing results are presented in Fig. 4.9. These results encapsulate power generation, solar radiation, and temperatures.

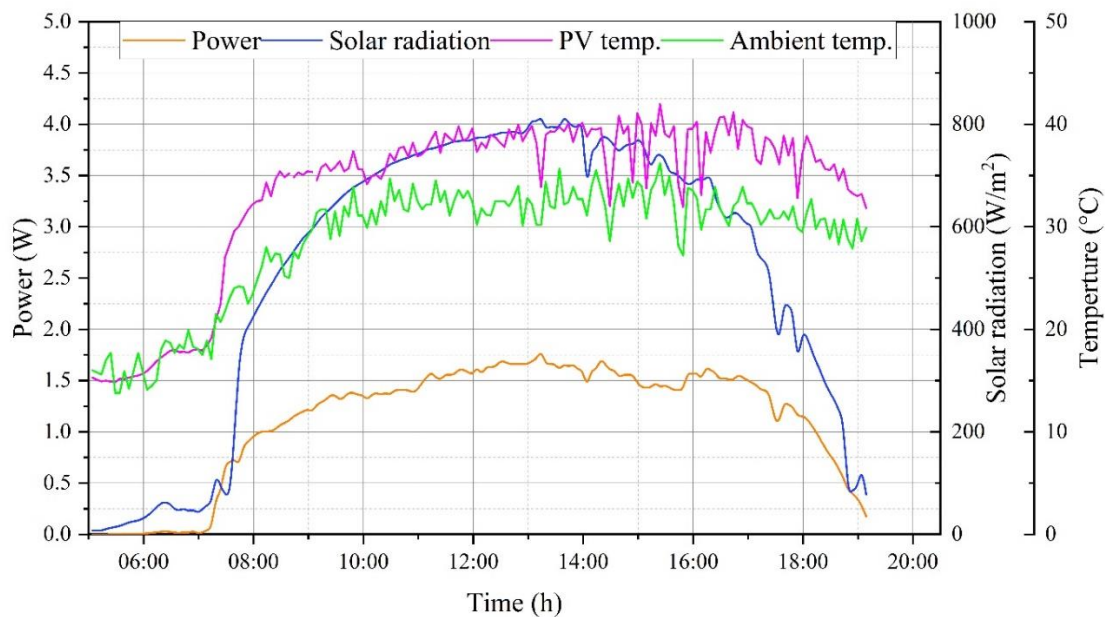

Fig. 4.9. The power generated from two hemispherical shapes

The increment in power generation, when compared to a singular hemisphere, transpires at a rate slightly less than twofold. While substantial, the relative increase in power production is not purely proportional to the addition of a second hemisphere. The observed phenomenon is primarily attributed to the shadow cast by one hemispherical shape onto the other, resulting in an energy loss. This shadowing effect arises because the separation distance between the first and second hemispheres is 40 cm, which proves inadequate to mitigate this form of energy loss

effectively. Furthermore, it is noteworthy that the average temperature of the solar modules exhibits a marginal decrease of 1.8 °C compared to the single hemispherical configuration, possibly due to improved heat dissipation due to the addition of the second hemisphere.

The surface of the hemisphere has a variation in temperature, with the highest temperature recorded at 46.6 °C for a solar module corresponding to direct sunlight, compared to 31 °C for the air temperature. As for the rest of the solar modules, they were variable, and there is no equality between any two solar modules at the same time due to the changing angle of incidence of sunlight on the spherical surface. The average temperature was 38.2 °C, which is the highest average temperature during the day.

Hemispherical configurations can create visually captivating geometric patterns that enhance the aesthetic appeal of urban spaces. These elegant and artistic designs not only contribute to the visual charm of the environment but also serve to heighten public awareness regarding using clean and sustainable energy sources. The single spherical shape generated a higher power than the parallel two hemispheres by 12.5%. This is due to the generation of shadowy areas on the lower hemisphere by the upper hemisphere, which caused these losses.

4.2.5. Three hemispherical PV modules

The three-dimensional PV system shows behaviour similar to the two hemispherical PV modules, as illustrated in Fig. 4.10, the power generation curve, solar radiation levels, and temperature. The power generation remains uniform throughout the day, reflecting exceptional stability and efficiency.

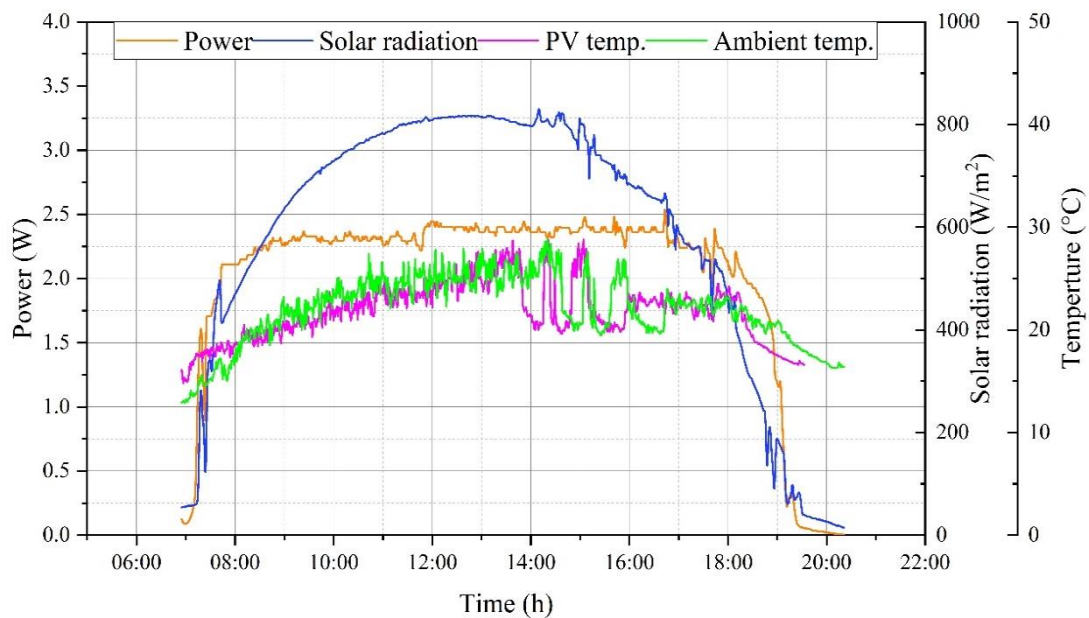

Fig. 4.10. The power generated from three hemispherical shapes

The capability to generate an average power of 2.4 W at an incident solar irradiance of 600 W/m² is noteworthy. This accomplishment distinguishes these hemispherical configurations by their ability to generate significant electrical energy without heavily relying on high-intensity

direct solar radiation. The key lies in a substantial number of solar cells proficiently harnessing energy from direct sunlight and reflected or scattered solar energy. Leveraging scattered solar radiation contributes to the behaviour of the electrical power generation curve, which closely mirrors the performance of solar tracker systems. This capacity to effectively utilize dispersed sunlight further highlights the adaptability and efficiency of these hemispherical shapes in generating electrical power.

The proximity of the average temperature of the solar modules to the surrounding ambient temperature is a notable feature, ensuring that all temperatures remain within the acceptable operational range. This close alignment with working temperatures is instrumental in preserving the efficiency of the solar modules, thereby facilitating the consistent generation of electrical energy. Notably, the region directly exposed to sunlight experiences a temperature differential, typically ranging from 5.3 to 7.5 °C higher than the ambient temperature. However, this variance quickly diminishes as the sun changes position and the direction of direct sunlight shifts.

Conversely, areas in the shade or on the side opposite to the direction of sunlight exhibit temperatures approximately 1 to 2 °C lower than the ambient temperature. These temperature variations correspondingly shift with changes in the solar projection's orientation. This temperature behaviour attests to the dynamic thermal response of the hemispherical configurations, influenced by the sun's movements and the distribution of solar energy.

4.3. Solar tree mode

4.3.1. The temperature of PV modules

The interval from 10:00 to 15:00 constitutes the prime window for effective solar energy harvesting. During this period, solar irradiance levels were meticulously documented to facilitate a comparative analysis of the temperatures across disparate photovoltaic (PV) module configurations, thereby elucidating the thermal disparities between them. It is well-established that PV modules are susceptible to thermal influences, with their efficiency inversely correlating with rising temperatures. Notably, the inclination angle of the PV modules was determined to have a negligible impact on the temperature of the solar modules.

4.3.1.1. The tilt angle of 45°

the flat PV module registered a peak temperature of 49.8 °C at 11:50, while the central area of the sunflower configuration simultaneously recorded a maximum temperature of 38.05 °C. The temperature fluctuations depicted in Fig. 4.11 can be attributed to considerable variations in wind speed, ranging from 12 to 30 km/h. The mean temperature disparities between the flat PV module, the sunflower, and the ambient air are quantified at 25.2 °C and 12.1 °C, respectively. The temperature of the conventional system exhibited a 23.5% increase compared to that of the solar tree. This confers a considerable advantage to the sunflower-inspired design regarding energy generation, as photovoltaic systems typically exhibit diminished efficiency with elevated temperatures.

4. Results

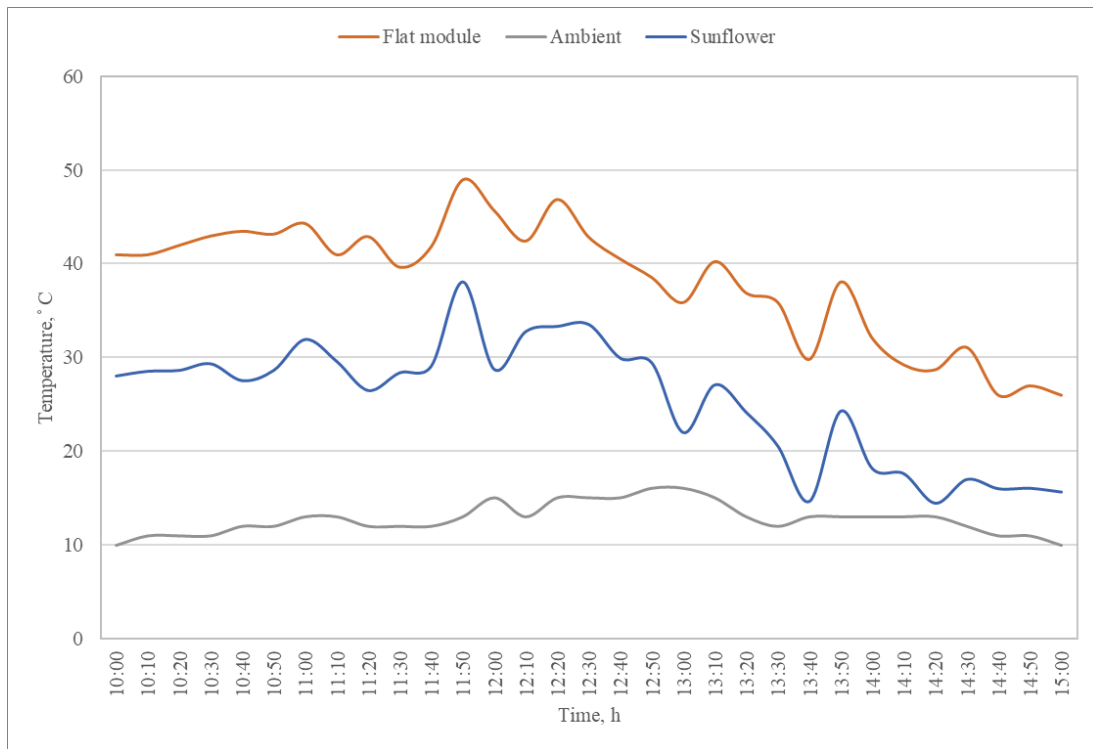

Fig. 4.11. PV systems temperature measurement ($\alpha=45^\circ$)

The photovoltaic (PV) systems have reduced ground temperature by casting shadows upon it. The average temperature difference between the ground and the shadow created by the sunflower configuration is 1.8 °C. In contrast, the average temperature differential between the ground and the shadow of the flat PV module is 6.7 °C. Fig. 4.12, illustrates the comparative analysis of ground temperature relative to the shaded areas produced by the PV systems.

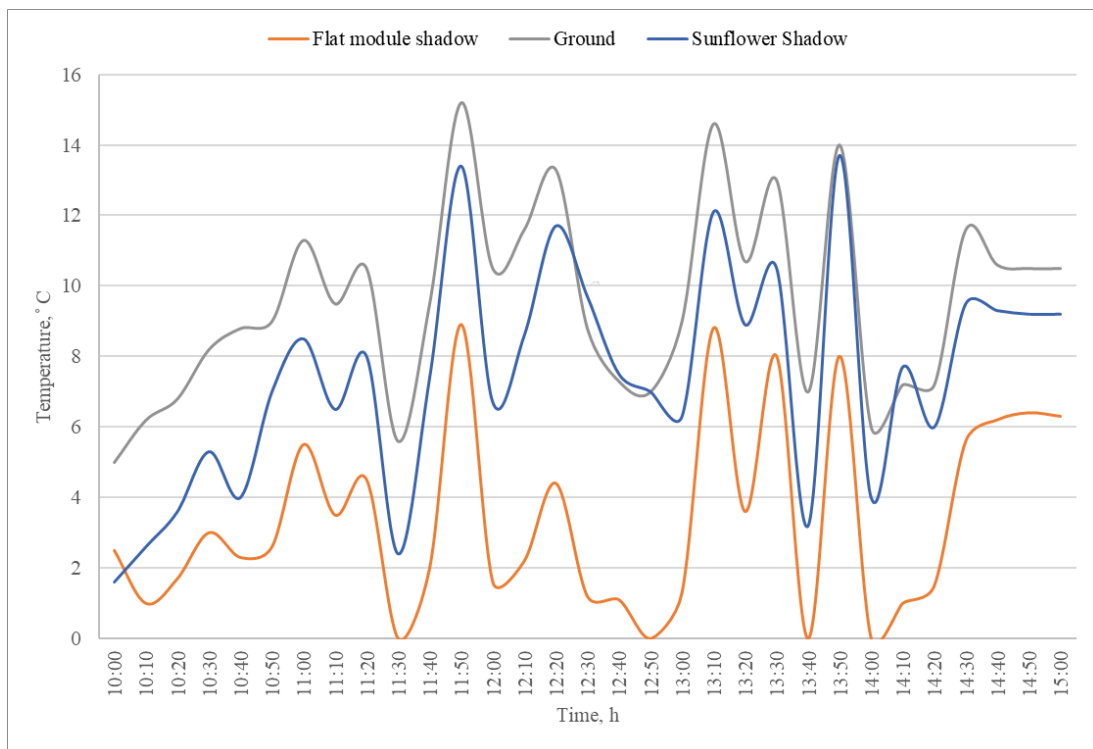

Fig. 4.12. the shaded and unshaded ground temperatures ($\alpha=45^\circ$)

4.3.1.2. The tilt angle of 30°

The maximum temperature documented for the flat photovoltaic (PV) module reached 51.3 °C at 12:00, as illustrated in Fig 4.13. Simultaneously, the apex temperature within the central region of the sunflower structure was recorded at 40.75 °C. The mean temperature divergence between the flat PV module, the sunflower module, and the ambient temperature is noted to be 23 °C and 10.4 °C, respectively.



Fig. 4.13. PV systems temperature measurement ($\alpha=30^\circ$)

The average temperature discrepancy between the ground and the shadow cast by the sunflower configuration stands at 3.0 °C, while the mean temperature variance between the ground and the flat PV module is 7.1 °C. Fig 4.14, delineates the temperature gradient between the ground and the areas shaded by the PV systems.

The reduction in ground temperature within the shadow cast by photovoltaic modules remains relatively stationary in traditional systems, enabling the application of this technology for the cooling of building rooftops. Conversely, in solar tree designs, the shadow delineates an arc, providing dynamic shading that is conducive to agricultural applications and other uses.

4. Results

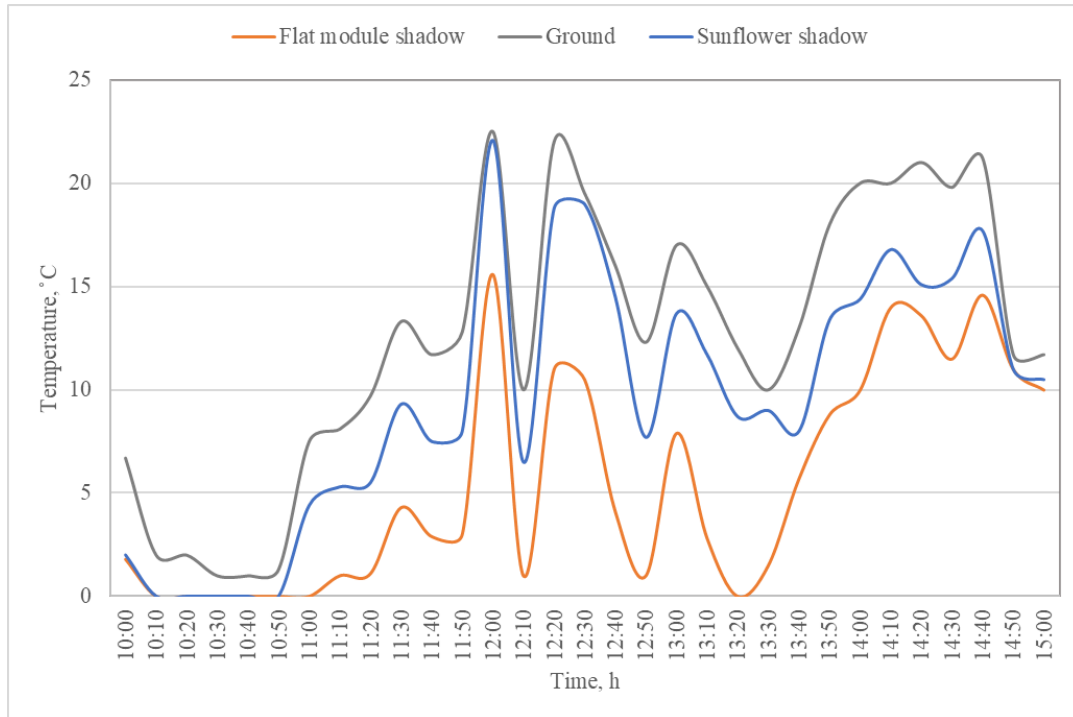

Fig. 4.14. The shaded and unshaded ground temperatures ($\alpha=30^\circ$)

4.3.1.3. The tilt angle of 20°

At a tilt angle ($\alpha = 20^\circ$), the peak temperature registered for the flat PV module was 43.86°C at 12:00, as depicted in Fig. 4.15. Concurrently, the maximum temperature observed at the centre of the sunflower configuration was 33.95°C . The average temperature differentials for the flat PV module and the sunflower module in relation to the ambient temperature are quantified as 12.3°C and 5.2°C , respectively. This thermal regulation is of paramount importance as it directly influences the efficiency of photovoltaic cells in converting solar energy into electricity. The temperature of the photovoltaic cell is inversely proportional to its operational efficiency; thus, the ability of solar trees to maintain a lower temperature profile stands as a significant advantage. This characteristic extends the service life of the photovoltaic cells and bolsters their energy conversion efficiency, making solar trees a promising avenue for urban and agricultural photovoltaic applications where space and aesthetic value are paramount.

4. Results

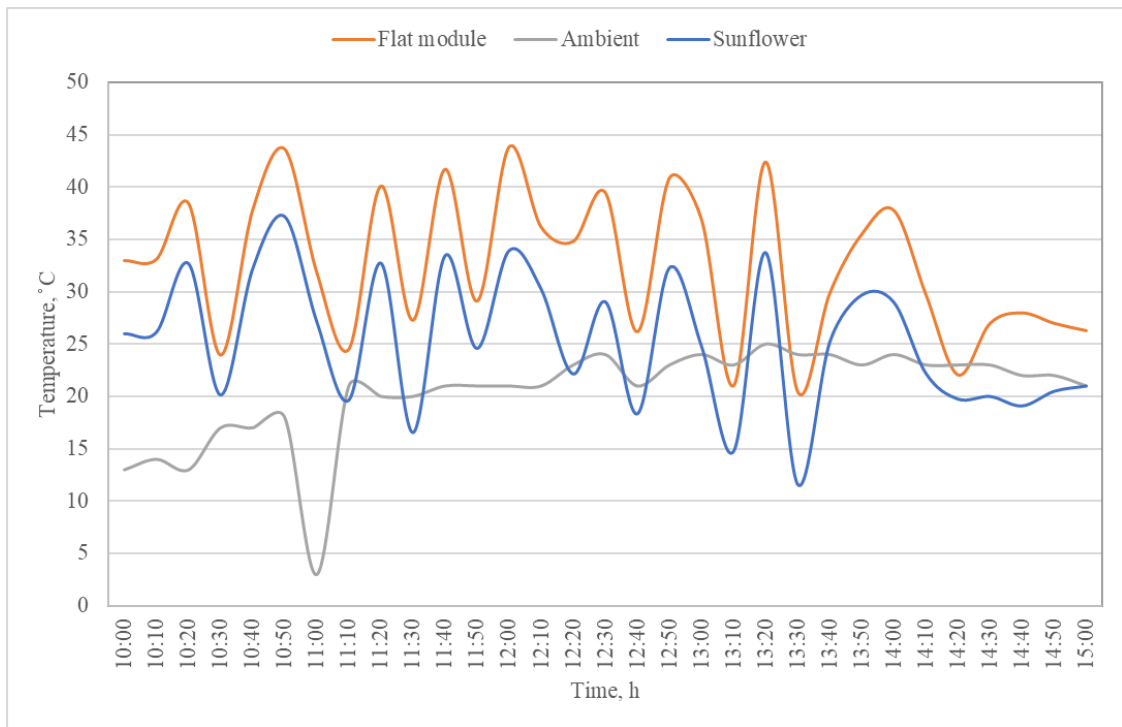

Fig. 4.15. PV systems temperature measurement ($\alpha=20^\circ$)

The mean temperature differential between the ground and the shadow cast by the sunflower configuration is 3.1°C , whereas the average temperature discrepancy between the ground and the shadow of the flat photovoltaic module is 6.6°C . Fig 4.16, illustrates the variance in temperature between the ground and the areas shaded by the PV systems.

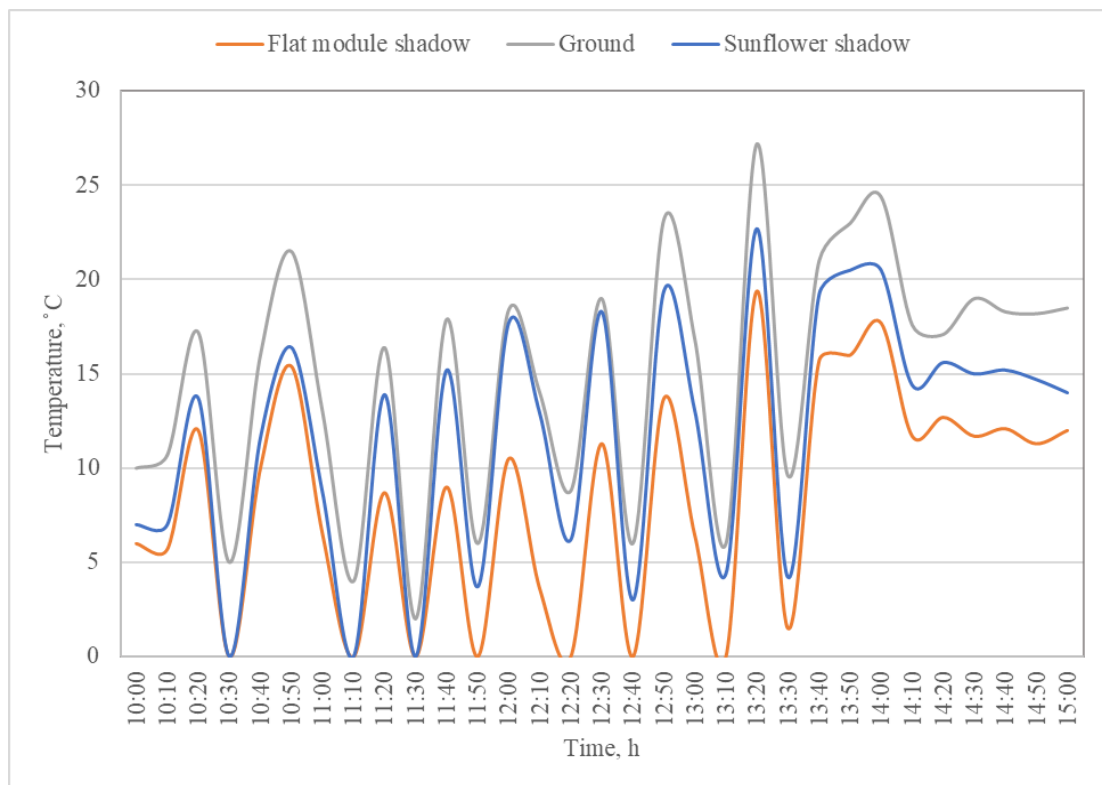

Fig. 4.16. The shaded and unshaded ground temperatures ($\alpha=20^\circ$)

The photovoltaic (PV) modules were subjected to a series of inclination tests at angles of 20, 30, and 45 degrees, with the resultant temperatures of the modules demonstrating minimal variance when juxtaposed with the ambient air temperature. As depicted in Figs 4.11, 4.13, and 4.15, the ambient air temperature was observed to be lower than that of the flat PV module and the sunflower configuration by an average of 7 °C and 15 °C, respectively. Fig 4.15 prominently illustrates the divergence and discordance between the temperatures of the photovoltaic (PV) modules and the ambient air temperature. This phenomenon can be attributed to the incidence of brisk winds, which facilitate the cooling of the PV modules despite the presence of intense solar radiation and an atmosphere devoid of dust and particulate obstructions. A notable temperature gradient is observed across the sunflower-configured modules, with the highest thermal readings centralized within the core of the solar tree, while the peripheries register cooler temperatures, owing to the air currents traversing the interstices among the solar tree's limbs. The shaded ground beneath the flat module experienced a greater reduction in temperature compared to that overshadowed by the solar tree, given an equivalent surface area of photovoltaic (PV) modules. The sunflower configuration casts a shadow upon the terrain, mimicking the silhouette of a solar tree, with its influence tracing an arc-like trajectory from dawn to dusk. Owing to the penetration of solar rays through the interspaces of the solar tree's branches, the thermal differential between the shaded and unshaded areas remains marginal. Figs 4.12, 4.14, and 4.16 depict that the ground temperature exceeds that of the projected area of both the flat and sunflower module configurations by an average of 7 °C and 2 °C, respectively. This disparity substantiates the efficacy of flat photovoltaic (PV) modules in facilitating ground cooling. Such a temperature modulation is consequential for the cooling load of buildings when these modules are installed atop roofs. The resultant decrease in ceiling surface temperatures may confer a positive economic impact by mitigating energy consumption required for interior climate control.

4.3.2. The power generation

The primary role of solar PV modules is converting solar irradiance into electrical energy. Fig. 4.17, elucidates the current-voltage (I-V) characteristic curves for the sunflower-configured and flat PV modules. While both modules exhibit comparable operational characteristics, the sunflower module demonstrates a superior power output. The open-circuit voltage (V_{oc}) is more effective at high temperatures than the short-circuit current (I_{sc}). To find the Maximum Power Point (MPP), the optimum resistance must be loaded to the circuit by changing the variable resistance value, recording and analysing the results, and drawing the (I-V) curve. (MPP) The sunflower and flat PV systems are observed at 4.5 V and 4 V, respectively.

The behaviour depicted by these curves underscores the significance of temperature in influencing PV module performance. Under the assumption of continuous solar irradiation, a singular PV module has the potential to generate greater electrical energy output at lower temperatures. As a result, there is an inverse relationship between the voltage parameter and the module's temperature. The results showed that the effect of temperature was the main parameter in causing the difference between the (MPP) of the sunflower and the flat PV module due to experimenting with both systems at the same time and under the same conditions, and the results were 17.8 W and 14.05 W for sunflower and flat PV module respectively.

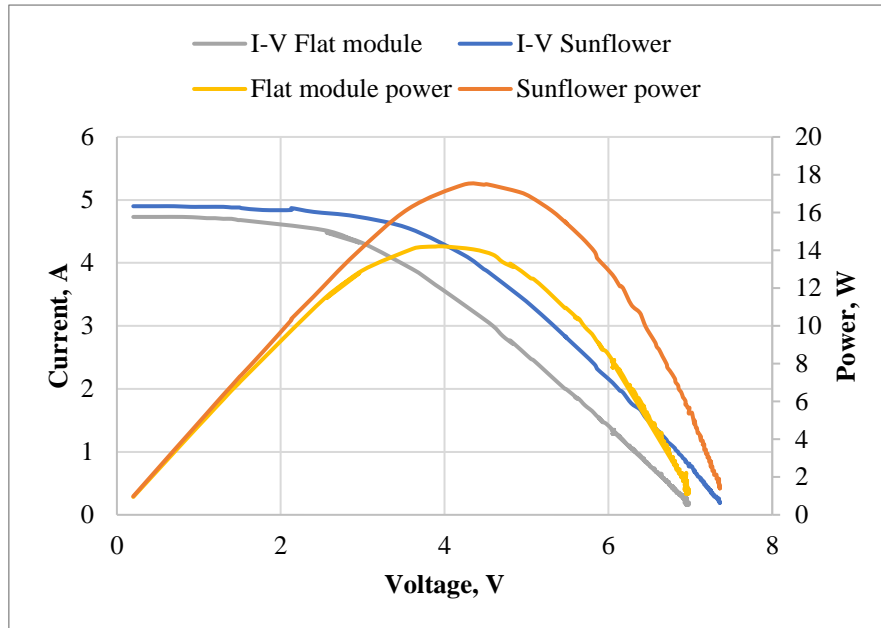

Fig. 4.17. I-V curve for PV module

4.3.2.1. The tilt angle of 45°

At an inclination angle of $\alpha=45$, the sunflower configuration yielded a maximum power output of 14.54 W, while the flat PV module produced 11.8 W. As indicated in the initial segment of Fig. 4.18, the flat PV module's performance was detrimentally impacted by rising temperatures, a factor that only marginally influenced the sunflower module. Nonetheless, the sunflower module remained within its operational temperature range.

The efficiency of solar cells is measured under Standard Test Conditions (STC), which stipulate a temperature of 25 °C for the solar PV module. Thus, it is the reference for measurement and assessment. Each solar PV module has its temperature effect factor, which affects the efficiency of the solar module when the temperature rises or falls below 25 °C. The temperature reduces efficiency due to the temperature effect factor of a flat module, which is 23.5% more than that of sunflowers.

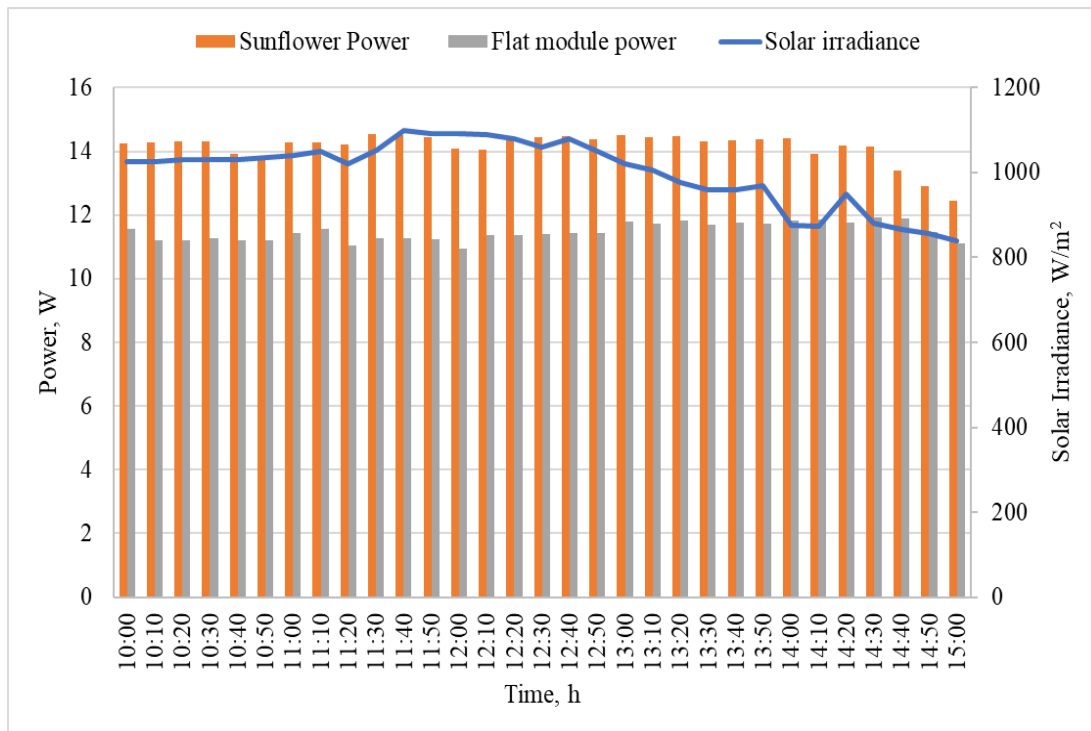

Fig. 4.18. Power generation from the sunflower and the flat PV module ($\alpha=45^\circ$)

4.3.2.2. The tilt angle of 30°

At an inclination angle of $\alpha=30^\circ$, the sunflower configuration manifested a maximum power output of 13.84 W, compared to 11.05 W for the flat PV module. Fig. 4.19, delineates the trajectory of electric power generation throughout the experimental period, alongside the concurrent solar irradiance measurement. Solar tree configurations have demonstrated a superior energy output, surpassing traditional flat systems by a margin of 20.15%. This increase in productivity may be attributed mainly to the thermoregulatory benefits given by the modules' planned spatial layout.

The intentional design allows unrestricted air circulation between the components, effectively dissipating the heat energy accumulated from continuous direct sun irradiation. The thermal profile within solar tree structures presents a marked variation, with the highest temperatures typically recorded at the core and progressively diminishing towards the outer extremities. Given the pronounced thermal differential, which can often surpass a magnitude of 10°C , a systematic approach to temperature assessment was necessitated. This approach entailed the calculation of an average temperature to accurately reflect the diverse thermal experiences of the modules, ensuring a comprehensive understanding of the thermal dynamics at play.

4. Results

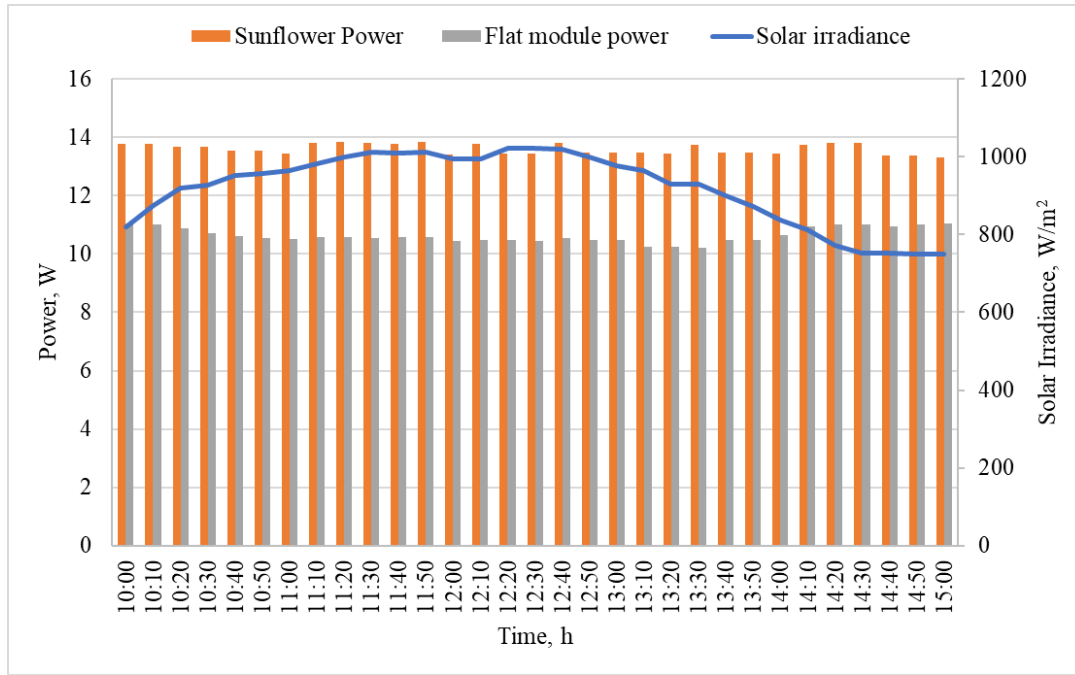

Fig. 4.19. Power generation from the sunflower and the flat PV module ($\alpha=30^\circ$)

4.3.2.3. The tilt angle of 20°

peak power outputs were recorded at 14.05 W for the sunflower configuration and 11.4 W for the flat PV module, as shown in Fig. 4.20. Throughout the experimental procedure, solar irradiance fluctuated between 780 and 1080 W/m². This irradiance range is optimal for maximizing solar PV modules' electric energy yield. Notably, the temperature of the PV module emerges as a crucial determinant in the efficacy of solar modules. It particularly impacts the performance of flat modules due to the reduced airflow. In contrast, the design of the sunflower module, featuring branches that permit air to circulate through the arms of the solar tree, enhances ventilation and consequently mitigates module temperature.

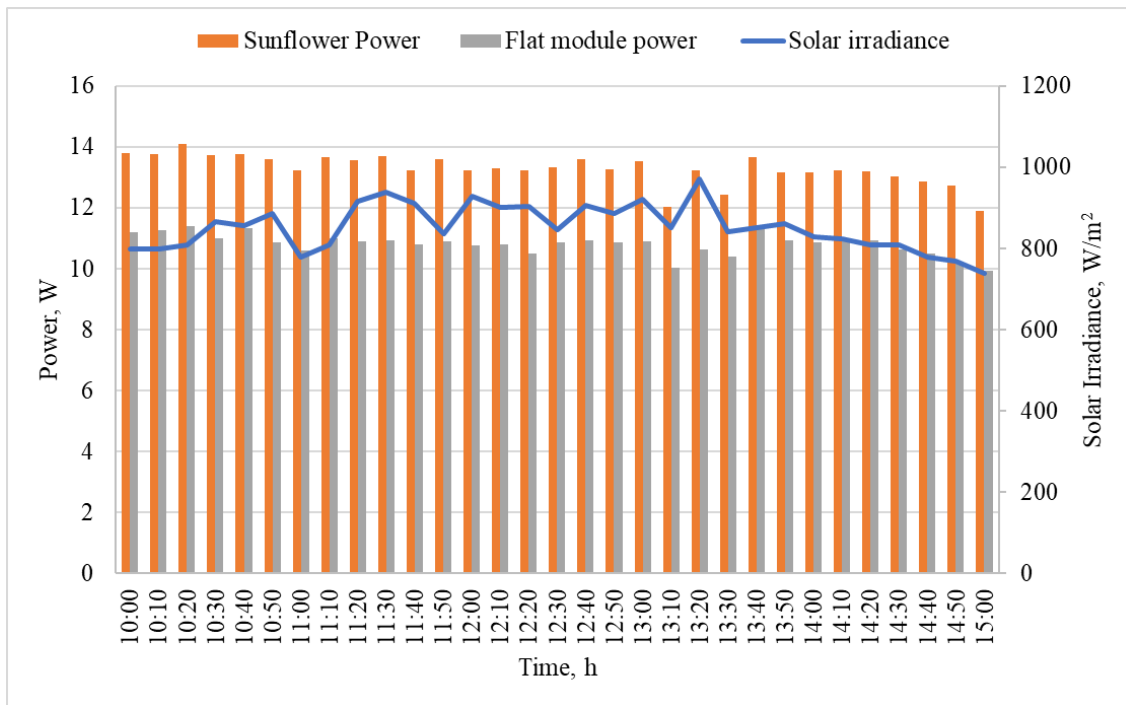

Fig. 4.20. Power generation from the sunflower and the flat PV module ($\alpha=20^\circ$)

Compared to solar trees, the disparity in solar module productivity escalated to as much as 23%. The influence of the PV module's inclination angle on power output proved to be minimal, attributable to the potency of solar irradiance, the lucidity of the atmosphere, and the lower ambient air temperature. Concurrently, the intrinsic high efficiency of the solar cells played a contributory role. In the third scenario, the selected degree of inclination emerged as the best angle for the performance of the photovoltaic system. This performance is attributed to the confluence of a temperate atmospheric environment and an advantageous solar angle, which collectively facilitated the most favourable energy production conditions. This finding aligns with the empirical study conducted by Zsiborács (2018), wherein an inclination of 20 degrees was identified as the optimal angle for achieving the highest yield of generated energy.

4.3.3. Positioning of PV modules for optimal solar tree design

The photovoltaic (PV) modules configured in the sunflower design engender an aesthetically pleasing form and facilitate air passage between the modules, thereby enhancing heat dissipation through convection. Empirical results indicate that the flat PV module's temperature exceeds the solar tree's by over 10 °C, owing to the less efficient convective heat transfer. Additionally, the temperatures of the ground shaded by the solar tree are reduced by 3 to 7 °C compared to the unshaded ground. This temperature reduction is even more pronounced in the context of the flat PV module.

The uniform southern orientation and identical tilt angles of the flat PV module and the solar tree ensure the comparability of the results. This study reveals that the proposed sunflower design yields an average increase in electrical energy production of 16 to 20% over the flat PV module under the same operational capacity and conditions. This enhancement is primarily attributed to the lower operational temperatures and improved ventilation of the PV modules within the solar tree, contributing to elevated energy output. The results converged with Elminshawy et al. (2022), who improved power productivity by 24% when the temperature decreased by 19%. Baci et al. (2020), and Rajaei and Jalai (2021) also obtained an increase in

the productivity of their solar trees by 22% and 12%, respectively, compared to a flat PV system with the same number of PV modules.

4.3.4. The land footprint of solar PV tree vs. flat PV module

Photovoltaic (PV) technology converts sunlight into electrical power, necessitating extensive areas for deploying large-scale systems. In urban contexts, where land costs are substantial, land footprint becomes critical in applying PV cell technology. This research undertakes a comparative analysis of the land area necessary for installing a solar tree equipped with a specified number of solar modules compared to a conventional flat PV system.

A conventional flat system incorporating eighteen solar modules requires a land area of 0.3125 m². This measurement accounts for the land directly under the solar modules, the surrounding clearance space on all four sides, and the inter-group spacing within a large-scale PV array. In comparison, the suggested sunflower structure, which can accommodate an equivalent of 18 solar modules, takes up just 0.01 m², or 3.2% of the land surface required by the flat PV system. As a result, 96% of the land in the footprint for solar technology implementations is saved.

In solar tree configurations, the solar modules are predominantly supported by a stand or stem, constructed from materials such as metal or wood to guarantee structural integrity, capacity to bear the system's components, and resilience against various weather conditions. Due to the comparatively modest cross-sectional area of the stem, solar trees present a noteworthy advantage for deployment in urban areas where land availability is constrained and valuable. Moreover, the space beneath these structures can be efficiently utilized for many applications, enhancing their functionality within space-constrained environments.

The findings of this research align with the record for the world's largest solar tree, as recognized by Guinness World Records. The Central Mechanical Engineering Research Institute, part of the government's Council of Scientific and Industrial Research, constructed this landmark structure. It features a solar panel surface area of 309.83 m² at the Centre of Excellence for Farm Machinery in Ludhiana, Punjab. The design boasts a generation capacity of 53.6 kW, which exceeds the former record-holding solar tree with a 67 m² PV module surface. This impressive solar tree can generate approximately 160-200 kWh of energy daily (Almadhhachi et al., 2022a).

4.4. Land occupancy ration

In the realm of energy infrastructure, an essential determinant is the ratio of energy occupancy to land, commonly referred to as the land coverage ratio. This ratio delineates the proportion of land area rendered unusable for alternative purposes due to the presence of structures relative to the overall land available for a given system site. A critical constraint associated with photovoltaic power plants pertains to the availability of expanses of land suitable for their establishment. This limitation is particularly pronounced in urban locales where the cost of land is prohibitive or where land is altogether scarce. Consequently, a judicious approach involves confining the construction of large-scale stations to desert areas or peripheral to urban centres. This strategic decision serves the dual purpose of mitigating land costs and confronting the challenge of efficiently transmitting or storing energy over extended distances.

The land footprint of conventional photovoltaic systems encompasses both the area occupied by solar modules and the adjacent spaces, rendering them unusable. In residential units, the

land footprint is predominantly synonymous with the area occupied by the solar modules. An avenue for optimizing land use within urban landscapes involves the incorporation of diverse shapes and patterns into the external structure of photovoltaic systems. This presents the opportunity to deploy large-scale systems within urban areas, thereby enhancing their integration and aesthetic appeal.

The adoption of singular hemispherical shapes in the context of the Land Coverage Ratio (LCR) yields a noteworthy reduction in the overall land requirement, constituting 66% of the total area. This reduction holds particular significance when applied to expansive domes situated atop buildings. However, the amalgamation of multiple domes results in a diminishing LCR, as the necessity for interspacing between domes offsets the benefits derived from reducing the land footprint. The mitigation of shading-induced energy losses, a consequence of dome proximity, is imperative. Shading becomes especially problematic as the diameter of the dome increases, with potentially adverse implications for energy yield. Large singular domes, whether ground-mounted or situated atop structures, emerge as an optimal solution for harnessing energy, minimizing land footprint, and introducing aesthetic considerations into the urban landscape.

Solar trees offer a distinct advantage by significantly minimizing the land footprint of photovoltaic systems, thereby effecting substantial reductions in the area occupied by such systems while concurrently introducing aesthetically pleasing elements to the surroundings. This reduction in footprint can be as substantial as 99% of the land typically required for establishing a power generation system.

Various configurations of solar trees exhibit disparities in energy output and design aesthetics, thereby contributing to the diversity of available options. Specifically, the sunflower tree demonstrates a noteworthy land footprint reduction, reaching up to 96 % of the total occupied land area. This translates into substantial savings, up to 85%, in land costs compared to the original expenditure for a conventional photovoltaic system. The black grape tree, comprising three solar balls, outperforms the sunflower tree in land footprint reduction. The reduction factor reaches an impressive 98%, resulting in substantial savings of 98% in actual land costs and an enhancement in aesthetic appeal. This tree design is inspired by nature, mimicking the structure of black grapes, and boasts versatility in applications within urban settings. Moreover, the flexibility to select the shape, size, and quantity of black grapes (solar spherical shapes) within a single tree or formation can amplify power generation while mitigating the terrestrial footprint associated with these installations.

4.5. Power/land occupancy ratio

Evaluating energy production relative to land footprint represents a fundamental consideration in the feasibility assessment of photovoltaic systems within urban environments. This is particularly crucial due to the elevated land cost in urban areas, resulting in an escalated expenditure associated with the establishment of power generation stations.

Different geometric configurations yield varying energy output in photovoltaic systems. Single hemispherical shapes, for instance, generate an energy yield of 0.540 kW/m². Bilateral hemispherical shapes are characterized by parallel hemispheres positioned at a 40 cm interval on a single axis and located in two parallel planes, the energy output increases to 0.780 kW/m². When three hemispherical shapes are arranged in parallel on a single axis with a 40 cm separation, the energy yield further increases to 1 kW/m². Spherical shapes exhibit an energy

generation of 0.808 kW/m^2 . The innovative design of the black grape tree, comprising three spherical shapes, achieves a notably higher energy yield of 1.252 kW/m^2 . Similarly, the sunflower tree surpasses with an energy output of 1.454 kW/m^2 .

This metric can be expressed as the quantity of energy generated in kilowatts within a one-square-meter area, serving as a pivotal parameter in assessing the efficiency and viability of various photovoltaic configurations within urban contexts.

4.6. New scientific results

This section presents the new scientific findings from this research work as follows:

1. *The inclined hemispherical PV module power*

Based on the experimental work, I have demonstrated a 6% increase in energy yield of the hemispherical shape compared to conventional PV systems with the same inclination angle. I have found that the hemispherical shapes, designed for solar energy harvesting, operate seamlessly from sunrise to sunset, emulating the functionality of solar tracking systems without any requirement for moving parts.

I have proven the arrangement of six PV modules on the outer surface of the hemispherical shape with a 45-degree inclination angle generates more power than the inclined conventional PV system.

I have pointed out that the inclination angle of the hemispherical PV module range is proportional to the solar incident angle to the observed pattern in the daily power generation curve, which aligns closely with the characteristic curve of solar tracking systems.

I have found the horizontal hemispherical PV module generates less power than the conventional PV module due to being affected by shadow on the opposite side of the incident solar light.

2. *Comparison of hemispherical and spherical PV modules*

The spherical configuration experiences limitations in direct sunlight exposure across its entire surface area, leading to energy losses. I have proved the hemispherical shapes present a favourable alternative. This unique placement empowers hemispherical modules to harness energy from direct sunlight and reflected and scattered sunlight. I have discovered that a hemispherical shape containing 30 modules can generate 1.4 W, while a spherical shape containing 60 modules can generate 2.04 W.

After changing the outer design of the PV module to get a new shape by adding aesthetic and power generation enhancement, I have found that the hemispherical PV module can generate more power than the spherical PV module by 32%. However, I have found both the spherical and hemispherical can play a role in aesthetic terms and the same behaviour of the power generation curve as a square function.

Comparing the spherical PV module with the horizontal hemispherical PV module has been done in performance for solar radiation range of 200 W.m^{-2} to 950 W.m^{-2} and the same weather conditions.

3. Modification of sunflower PV tree

Sunflowers are a unique combination of solar PV modules organised in a pattern that resembles the structure of a sunflower. This innovative design has a purposeful tilt of the solar modules, which aligns them with the path of sunlight throughout the day.

I have enhanced the thermal conditions of the system by enlarging the spaces between the PV modules. I experienced the result; it was a stunning temperature drop of 10 °C and 16 °C relative to the centre part and the edge of the sunflower, respectively. I have discovered it can generate more power than the conventional PV system by 20% because of the thermal enhancement of the PV system.

Furthermore, this thermoregulatory system is critical to ensure the maximum performance and lifetime of the PV modules since excessive heat can reduce efficiency and durability. The sunflower-inspired solar setup exemplifies a comprehensive approach to optimising thermal and energy performance, indicating a possible route for improving solar harvesting efficiency in various weather circumstances.

4. Reduction of the land footprint by sunflower PV

Based on practical experiences, I found the sunflower PV tree structures function as distinctive architectural additions to the urban landscape and are characterized by a solid vertical column with a 0.01 m² area firmly anchored to the ground. This column is the primary support for the elevated 18 solar PV modules strategically configured to bear artistic and visually appealing shapes with a 0.313 m² equivalent area relative to a conventional system. I have justified a significant 96% reduction in land footprint by implementing a sunflower PV tree.

Furthermore, adopting sunflower PV trees in urban areas embodies a forward-looking approach, offering a harmonious coexistence of renewable energy solutions and architectural ingenuity because the sunflower PV tree is inspired by nature. Integrating solar tree technology is a testament to the potential of merging eco-friendly initiatives with creative urban planning, fostering a more sustainable and aesthetically pleasing future.

5. Effect of solar tree for cooling down the shaded area

The solar tree prevents sunlight from reaching the ground. I have found the shaded ground area by the solar tree was affected by decreasing temperature by 23-28%, and the shaded ground area by the conventional PV module was affected by decreasing temperature by 35-39%. I have found it contributes to a discernible reduction in ground temperature, amounting to a decrease of 6 °C.

I have pointed out that this thermal effect presents an opportunity for leveraging the advantages inherent in this phenomenon across various applications. The potential applications underscore the multifaceted benefits of solar trees' shading effect in diverse urban and communal settings.

The PV system affects the shaded ground area if the ambient temperature is more than 10 °C and the solar radiation is more than 500 W.m⁻².

5. CONCLUSION AND SUGGESTIONS

In this research, novel spherical shapes were introduced to create hybrid solar trees, imparting an urban aesthetic reminiscent of real trees. Subsequently, an examination of flexible solar modules ensued, aiming to ascertain their efficacy, delineate their characteristics, and juxtapose them against mono and polycrystalline solar modules. The outcomes revealed that flexible modules have the potential to achieve an efficiency of up to 17%. The solar modules, enveloping hemispherical shapes, underwent testing and analysis across various solar module types, exploring diverse distributions of the hemispherical shapes to identify optimal form and arrangement. It was determined that hemispherical shapes arranged in an arc-shaped wave towards the sun, akin to a tracking system, surpassed other configurations in solar energy harvesting efficiency. This approach exhibited a 6% efficiency gain compared to traditional flat shapes while occupying a land footprint, amounting to 19% of that in flat systems with similar solar modules.

Given the impracticality of covering spherical shapes with rectangular modules, the study adopted smaller dimensions for the flexible modules. A specialized order was placed with a Chinese company for the production of these flexible solar modules. Notably, the hemispherical shapes, crafted from cork, were covered by flexible solar PV modules, constituting 70% of the total surface area. This configuration aimed to prevent overlap between adjacent flexible modules. The investigation demonstrated that hemispherical shapes generated 32% more power than spherical shapes, attributable to the presence of flexible modules positioned opposite to direct sunlight.

Solar trees exhibited a noteworthy reduction of 96% in the Earth's footprint compared to conventional photovoltaic systems. This characteristic holds the potential for implementing large-scale systems within urban settings to generate electrical energy.

Sunflowers exhibited commendable results in power production, surpassing traditional flat systems by up to 20%. This superiority is attributed to the effective dispersion of solar module heat, facilitated by the presence of empty spaces between modules, ensuring convection-based heat dissipation. Consequently, the ground temperature influenced by solar trees experienced a reduction of 6 °C.

A prospective initiative involves identifying companies interested in enhancing the external design of photovoltaic systems. Subsequently, a comprehensive feasibility study, incorporating detailed cost analysis, will be undertaken to determine the optimal structure for solar trees. This endeavour aims to present a realistic cost assessment for constructing solar trees adorned with sunflowers and black grapes. The overarching goal is to raise awareness among individuals, encouraging them to invest in clean energy sources as a means of mitigating pollution and reducing emissions.

6. SUMMARY

SOLAR PV TREE BASED ON SPHERICAL CONFIGURATION

Photovoltaic technology (PV) has emerged as a prominent environmentally friendly technology, undergoing significant advancements in recent years. However, it faces certain limitations, including high initial construction costs, extensive land requirements, relatively low efficiency, and aesthetically unappealing outcomes. This research aimed to address these limitations through the development of solar tree technology, which offers the potential to enhance urban aesthetics, minimize land footprint and improve PV system efficiency.

Novel spherical shapes were employed to construct hybrid solar trees, deviating from conventional commercial, artistic solar trees and closer to the natural form of trees. The black grape tree, revered for its inverted pyramidal fruit structures, served as inspiration for this design initiative. Flexible solar modules were integrated into the spherical structures to evaluate their efficiency, characteristics, and comparative performance against mono- and polycrystalline solar modules. Flexible modules demonstrated the potential to achieve up to 17% efficiency.

Hemispherical shapes covered by solar modules underwent rigorous testing and analysis, incorporating various solar module types and distribution patterns to identify the optimal configuration. The results indicated that hemispherical shapes with an arc-shaped wave orientation towards the sun, resembling a tracking system, exhibited superior energy harvesting capability. This configuration surpassed traditional flat shapes by 6% in efficiency while maintaining a land footprint that is up to 19% smaller. Because the spherical shapes cannot accommodate rectangular solar modules, customized small-dimension flexible modules were commissioned from a manufacturer. Polyester hemispherical structures were effectively covered by 70% of the flexible solar modules, ensuring minimal overlap. The overall spherical shape, adorned with flexible modules, exhibited a 32% power generation increase compared to hemispherical shapes due to the flexibility of the modules positioned away from direct sunlight.

Solar trees have demonstrated their potential to occupy a mere 2% of the land footprint compared to traditional PV systems. This feature holds immense promise for large-scale implementation within urban environments, generating electricity sustainably. Sunflower-shaped solar trees showcased remarkable power production, surpassing traditional flat systems by up to 20%. This enhanced performance stemmed from the effective dispersion of solar module temperatures, facilitated by the presence of empty spaces between the units, enabling heat dissipation through convection. This resulted in an average temperature difference of over 10 degrees.

In conclusion, the solar tree technology emerges as a promising solution to address the limitations of conventional PV systems, offering aesthetic appeal, reduced land footprint, and improved efficiency. The innovative spherical and sunflower-shaped designs demonstrate the potential for large-scale implementation within urban landscapes, contributing to sustainable energy generation.

7. ÖSSZEFOGLALÁS (SUMMARY IN HUNGARIAN) NAPELEMES FA GÖMBI KONFIGURÁCIÓ ALAPJÁN

A fotovillamos technológiák (PV) kiemelkedő környezetbarát megoldások, amely az elmúlt években jelentős fejlődésen mentek keresztül. Alkalmazásukkor bizonyos korlátokkal kell szembenézni, beleértve a magas építési költségeket, a kiterjedt helyigényt, a viszonylag alacsony hatásfokot és adott esetben az esztétikailag nem vonzó megjelenési formákat. Ennek a munkának az volt a célja, hogy a napelemes technológia fejlesztésén keresztül vizsgálja ezeket a korlátokat, amelyek révén lehetőség van a városi esztétika javítására, a környezeti és talaj lábnyom minimalizálására és a PV-rendszerek hatásfokának javítására. A hibrid napelem fák esetében új, gömb alakú formák kerültek bevezetésre, amelyek eltérnek a hagyományos kereskedelmi illetve művészeti napelem fáktól, és közelebb állnak a természetes fák formájához. A tervezéshez a fordított piramis alakú gyümölcsöt termő fekete szőlőfa szolgált alapul.

A munka során hajlékony napelem modulok kerültek elhelyezésre gömb alakú szerkezetekre, hogy értékelni lehessen azok hatékonyságát, karakterisztikájukat valamint a mono- és polikristályos napelem modulok teljesítményével való összehasonlítását. A hajlékony modulok alkalmazása lehetővé tette 17%-os hatásfok elérését.

Az optimális konfiguráció meghatározásához különféle típusú és elosztási mintázatú napelem modulokkal lefedett félgömb alakú formák kerültek tesztelésre és elemzésre. Az eredmények azt mutatták, hogy a nap felé mutató, íves, a napkövető rendszerre emlékeztető félgömb alakú formák kiváló energiatermelési képességűek. Ez a konfiguráció hatékonyságában 6%-kal felülmúlta a hagyományos sík formákat, miközben akár 19%-kal kisebb lefedési területet igényel. Mivel a gömb alakú szerkezeteken nem lehet jól elhelyezni a téglalap alakú napelem modulokat, ezért egyedileg tervezett, kisméretű hajlékony modulok kerültek alkalmazásra.

A poliészter anyagú, félgömb alakú szerkezetek még minimális átfedés esetén is mintegy 70%-ban, hatékonyan lefedhetők voltak a hajlékony napelem modulokkal. A hajlékony modulokat tartalmazó általános gömbforma 32%-os energiatermelési növekedést mutatott a félgömb alakúakhoz képest, még diffúz napsugárzás esetén is.

A vizsgálatok igazolták, hogy a szoláris fák a hagyományos PV-rendszerekhez képest a földterület mindössze 2%-át foglalják el. Ez a lehetőség nagyon ígéretes a városi környezetben történő nagyobb méretű alkalmazásokban, és így a fenntartható villamosenergia termelésben. A napraforgó alakú napelemfák jelentős energiatermelést mutattak, akár 20%-kal felülmúlva a hagyományos sík rendszereket. Ez a megnövekedett teljesítmény a napelemek hőmérsékletének kedvezőbb eloszlásából ered, amelyet az egységek közötti üres terek megléte tesz lehetővé, a hatékonyabb konvekciós hőelvezetés révén. Ez 10 °C feletti átlagos hőmérséklet csökkenést eredményezett.

Összefoglalva megállapítható, hogy a napelemes fa technológia ígéretes megoldást jelent a hagyományos PV-rendszerek korlátjainak leküzdésére, biztosítva az esztétikus megjelenést, a kisebb lefedési területet és a jobb hatékonyságot. Az innovatív gömb- és napraforgó alakú kialakítások demonstrálják a városi tájképekbe való beilleszkedés lehetőségét, és egyben hozzájárulnak a fenntartható energiatermeléshez.

8. APPENDICES

A1: Bibliography

1. Abdelsalam, A.K., Shahin, H.T., Morsi, I., (2017): Hybrid electro-mechanical photovoltaic maximum power point tracking technique for innovative solar trees. 2017 IEEE 2nd Int. Conf. Direct Curr. Microgrids, ICDCM 2017 406–414. <https://doi.org/10.1109/ICDCM.2017.8001078>
2. Abdollahpour, M., Golzarian, M.R., Rohani, A., Abootorabi Zarchi, H., (2018): Development of a machine vision dual-axis solar tracking system. *Sol. Energy* 169, 136–143. <https://doi.org/10.1016/j.solener.2018.03.059>
3. Aghaei M., Fairbrother A., Gok A., Ahmad S., Kazim S., Lobato K., Oreski G., Reinders A., Schmitz J., Theelen M., Yilmaz P., Kettle J., (2022): Review of degradation and failure phenomena in photovoltaic modules. *Renewable and Sustainable Energy Reviews*. 16, 2. <https://doi.org/10.1016/j.rser.2022.112160>
4. Aiden, 2011. The Secret of the Fibonacci Sequence in Trees (2011): URL <https://www.amnh.org/learn-teach/curriculum-collections/young-naturalist-awards/winning-essays/2011/the-secret-of-the-fibonacci-sequence-in-trees>
5. Al-Rousan, N., Al-Najjar, H., Alomari, O., (2021): Assessment of predicting hourly global solar radiation in Jordan based on Rules, Trees, Meta, Lazy and Function prediction methods. *Sustain. Energy Technol. Assessments* 100923. <https://doi.org/10.1016/j.seta.2020.100923>
6. Al-Yasiri, Q., Géczi, G., (2021): Global Warming Potential: Causes and Consequences. *Acad. Lett.* <https://doi.org/10.20935/al3202>
7. Al-Yasiri, Q., Szabó, M., Arıcı, M., (2022): A review on solar-powered cooling and air-conditioning systems for building applications. *Energy Reports* 8, 2888–2907. <https://doi.org/10.1016/j.egy.2022.01.172>
8. AlAmri, F., AlZohbi, G., AlZahrani, M., Aboulebdah, M., (2021): Analytical modeling and optimization of a heat sink design for passive cooling of solar PV panel. *Sustain.* 13, 3490. <https://doi.org/10.3390/su13063490>
9. Alktranee, M., Shehab, M.A., Németh, Z., Bencs, P., Hernadi, K., Koós, T., (2022): Energy and exergy assessment of photovoltaic-thermal system using tungsten trioxide nanofluid: An experimental study. *Int. J. Thermofluids* 16, 100228. <https://doi.org/10.1016/J.IJFT.2022.100228>
10. Alktranee, M.H.R., Al-Yasiri, Q., Sahib, M.M., (2020): Power output enhancement of grid-connected PV system using dual-axis tracking. *Renew. Energy Environ. Sustain.* 5, 8. <https://doi.org/10.1051/rees/2020002>
11. Almadhhachi, M., MacHi, M.H., Jaber, M.F., (2020): Enhancement of charging system for electrical vehicle using PV panels. *J. Mech. Eng. Res. Dev.* 43, 223–229.
12. Almadhhachi, M., Seres, I., Farkas, I., (2023): Electrical power harvesting enhancement of PV module by a novel hemispherical configuration. *Int. J. Thermofluids* 20, 100460. <https://doi.org/https://doi.org/10.1016/j.ijft.2023.100460>
13. Almadhhachi, M., Seres, I., Farkas, I., (2022): Significance of solar trees: Configuration, operation, types and technology commercialization. *Energy Reports* 8, 6729–6743. <https://doi.org/10.1016/j.egy.2022.05.015>

14. Almadhhachi, M., Seres, I., Farkas, I., (2022): Comparison of the efficiency of polycrystalline and thin-film photovoltaic outdoors. *Eur. J. Energy Res.* 2, 9–12. <https://doi.org/10.24018/ejenergy.2022.2.2.43>
15. Almadhhachi, M., Seres, I., Farkas, I., (2020): Concept of a solar cell operated hybrid tree. *Mech. Eng. Lett.* 20, 96–100.
16. Alshawaf, M., Poudineh, R., Alhajeri, N.S., (2020): Solar PV in Kuwait: The effect of ambient temperature and sandstorms on output variability and uncertainty. *Renew. Sustain. Energy Rev.* 134, 110346. <https://doi.org/10.1016/j.rser.2020.110346>
17. Alshibil, A.M.A., Farkas, I., Víg, P., (2022): Multi-aspect approach of electrical and thermal performance evaluation for hybrid photovoltaic/thermal solar collector using TRNSYS tool. *Int. J. Thermofluids* 16, 100222. <https://doi.org/https://doi.org/10.1016/j.ijft.2022.100222>
18. Amr, A.A., Hassan, A.A.M., Abdel-salam, M., El-sayed, A.M., (2019): Enhancement of photovoltaic system performance via passive cooling: Theory versus experiment. *Renew. Energy* 140, 88–103. <https://doi.org/10.1016/j.renene.2019.03.048>
19. Arisetyadhi, I., Dewi, T., Kusumanto, R., (2020): Experimental Study on The Effect of Arches Setting on Semi-Flexible Monocrystalline Solar Panels. *Kinet. Game Technol. Inf. Syst. Comput. Network, Comput. Electron. Control* 111–118. <https://doi.org/10.22219/kinetik.v5i2.1055>
20. Asaduzzaman, M., Hasan, M., Bahar, A.N., (2016): An investigation into the effects of band gap and doping concentration on Cu(In,Ga)Se₂ solar cell efficiency. *Springerplus* 5. <https://doi.org/10.1186/s40064-016-2256-8>
21. Avdic, V., Zecevic, S., Pervan, N., Tasic, P., Muminovic, (2013): Different Design Solutions of Solar Trees in Urban Environment. *Green Des. Conf.* 3–7.
22. Awan, A.B., Alghassab, M., Zubair, M., Bhatti, A.R., Uzair, M., Abbas, G., (2020): Comparative analysis of ground-mounted vs. rooftop photovoltaic systems optimized for interrow distance between parallel arrays. *Energies* 13. <https://doi.org/10.3390/en13143639>
23. Awasthi, A., Shukla, A.K., Murali Manohar, S.R., Dondariya, C., Shukla, K.N., Porwal, D., Richhariya, G., (2020): Review on sun tracking technology in solar PV system. *Energy Reports* 6, 392–405. <https://doi.org/10.1016/j.egy.2020.02.004>
24. Ayora, E., Munji, M., Kaberere, K., Thomas, B., (2023): Performance analysis of 600 kWp grid-tied rooftop solar photovoltaic systems at strathmore university in Kenya. *Results Eng.* 19, 101302. <https://doi.org/https://doi.org/10.1016/j.rineng.2023.101302>
25. Baci, A.B., Salmi, M., Menni, Y., Ghafourian, S., Sadeghzadeh, M., Ghalandari, M., (2020): A New Configuration of Vertically Connecting Solar Cells: Solar Tree. *Int. J. Photoenergy* 2020. <https://doi.org/10.1155/2020/8817440>
26. Bakhshi, R., Sadeh, J., (2018): Economic evaluation of grid-connected photovoltaic systems viability under a new dynamic feed-in tariff scheme: A case study in Iran. *Renew. Energy* 119, 354–364. <https://doi.org/10.1016/j.renene.2017.11.093>
27. Balaji, J., Rao, P.N., Rao, S.S., (2020): Solar tree with different installation positions of photovoltaic module-part 2. *J. Green Eng.* 10, 4639–4656.

28. Bandyopadhyay, K., (2020): CMERI installed the world's largest solar tree at Durgapur. <https://timesofindia.indiatimes.com/india/cm-eri-installed-the-worlds-largest-solar-tree-at-durgapur/articleshow/77856790.cms?from=mdr>
29. Bantikata, H., Nulu, L.D.S.M.P., Bhogaju, R., Narlanka, P., Siddi, V.R., Royal, K.K., Hymavathi, A., (2019): Design and fabrication of hybrid solar silicon PV system. *Mater. Today Proc.* 19, 761–766. <https://doi.org/10.1016/j.matpr.2019.08.126>
30. Bayrak, F., Oztop, H.F., Selimefendigil, F., (2019): Effects of different fin parameters on temperature and efficiency for cooling of photovoltaic panels under natural convection. *Sol. Energy* 188, 484–494. <https://doi.org/10.1016/j.solener.2019.06.036>
31. Bernardi, M., Ferralis, N., Wan, J.H., Villalon, R., Grossman, J.C., (2012): Solar energy generation in three dimensions. *Energy Environ. Sci.* 5, 6880–6884. <https://doi.org/10.1039/c2ee21170j>
32. Berny, S., Blouin, N., Distler, A., Egelhaaf, H.J., Krompiec, M., Lohr, A., Lozman, O.R., Morse, G.E., Nanson, L., Pron, A., Sauermann, T., Seidler, N., Tierney, S., Tiwana, P., Wagner, M., Wilson, H., (2015): Solar trees: First large-scale demonstration of fully solution coated, semitransparent, flexible organic photovoltaic modules. *Adv. Sci.* 3, 1–7. <https://doi.org/10.1002/advs.201500342>
33. Bingham, A., (2012): Ross Lovegrove, <https://www.designboom.com/design/ross-lovegrove-solar-tree-at-clerkenwell-design-week/>
34. Cao, W., Li, Z., Yang, Y., Zheng, Y., Yu, W., Afzal, R., Xue, J., (2014): “Solar tree”: Exploring new form factors of organic solar cells. *Renew. Energy* 72, 134–139. <https://doi.org/10.1016/j.renene.2014.06.045>
35. Chitra, K., Ahmed, K., Yadav, D., Passi, P., Sreedhar, D., Madhan Gopal, M.E., (2019): Design and implementation of a solar tree structure for efficient LED street lighting. *Int. J. Eng. Adv. Technol.* 8, 2453–2456. <https://doi.org/10.35940/ijeat.F8546.088619>
36. D’Agostino, D., Parker, D., Melià, P., Dotelli, G., (2022): Optimizing photovoltaic electric generation and roof insulation in existing residential buildings. *Energy Build.* 255, 111652. <https://doi.org/10.1016/j.enbuild.2021.111652>
37. Dash, P.K., Gupta, N.C., (2015): Effect of temperature on power output from different commercially available photovoltaic modules. *J. Eng. Res. Appl.* 5, 148–151.
38. de Abreu-Harbach, L.V., Labaki, L.C., Matzarakis, A., (2015): Effect of tree planting design and tree species on human thermal comfort in the tropics. *Landsc. Urban Plan.* 138, 99–109. <https://doi.org/10.1016/j.landurbplan.2015.02.008>
39. Deep, R., Mishra, A., Agarwal, A., (2020): Comparative Analysis of Solar Panel Output Power: Matrix Vs Tree Form. *MATEC Web Conf.* 307, 01002. <https://doi.org/10.1051/mateconf/202030701002>
40. Deepak M. Patil, S.R.M., (2018): Design and development of solar tree for domestic applications. *Int. J. Eng. Sci. Res. Technol.* 7, 75–81.
41. Dey, S., Lakshmanan, M.K., Pesala, B., (2018): Optimal solar tree design for increased flexibility in seasonal energy extraction. *Renew. Energy* 125, 1038–1048. <https://doi.org/10.1016/j.renene.2018.02.017>

42. Dey, S., Pesala, B., (2020): Solar tree design framework for maximized power generation with minimized structural cost. *Renew. Energy* 162, 1747–1762. <https://doi.org/10.1016/j.renene.2020.07.035>
43. Dhaundiyal, A., Atsu, D., (2021): Energy assessment of photovoltaic modules. *Sol. Energy* 218, 337–345. <https://doi.org/10.1016/j.solener.2021.02.055>
44. Dimroth, F., (2014): New world record for solar cell efficiency at 46%. Press Release, Presse information.
45. Duffie, J.A., Beckman, W.A., Blair, N., (1985): *Solar engineering of thermal processes, photovoltaics and wind*, 5th ed. ed, American Journal of Physics. New Jersey.
46. Duffie, J.A., Beckman, W.A., Worek, W.M., (1994): *Solar Engineering of Thermal Processes*, 2nd ed. *J. Sol. Energy Eng.* 116, 67–68. <https://doi.org/10.1115/1.2930068>
47. Duque, E.A., Ortiz, P.M., Isaza, A.F., Lujan, A.F., Chica, S., Casamitjana, M., (2018): Design and Construction consideration of an artificial solar tree made with *Guadua angustifolia* to charge mobile devices in medellin. *Indian J. Sci. Technol.* 11, 1–11. <https://doi.org/10.17485/ijst/2018/v11i15/119013>
48. Eicker, U., (2005): *Solar Technologies for Buildings*, Solar Technologies for Buildings. Wiley, Germany. <https://doi.org/10.1002/0470868341>
49. Ekici, S., Kopru, M.A., (2017): Investigation of PV system cable losses. *Int. J. Renew. Energy Res.* 7, 807–815.
50. El Majid, B., Motahhir, S., El Ghzizal, A., (2019): Parabolic bifacial solar panel with the cooling system: concept and challenges. *SN Appl. Sci.* 1, 1–3. <https://doi.org/10.1007/s42452-019-1223-8>
51. Elibol, E., Özmen, Ö.T., Tutkun, N., Köysal, O., (2017): Outdoor performance analysis of different PV panel types. *Renew. Sustain. Energy Rev.* 67, 651–661. <https://doi.org/10.1016/j.rser.2016.09.051>
52. Elminshawy, N., Elminshawy, A., Osama, A., Bassyouni, M., Arıcı, M., (2022): Experimental performance analysis of enhanced concentrated photovoltaic utilizing various mass flow rates of Al₂O₃-nanofluid: Energy, exergy, and exergoeconomic study. *Sustain. Energy Technol. Assessments* 53, 102723. <https://doi.org/10.1016/J.SETA.2022.102723>
53. Fairs, M., (2007): Ross Lovegrove Unveils Spectacular Solar Tree. <https://www.dezeen.com/2007/09/27/solar-tree-by-ross-lovegrove/>
54. Fathabadi, H., (2016): Novel high accurate sensorless dual-axis solar tracking system controlled by maximum power point tracking unit of photovoltaic systems. *Appl. Energy* 173, 448–459. <https://doi.org/10.1016/j.apenergy.2016.03.109>
55. Gangwar, P., Kumar, N.M., Singh, A.K., Jayakumar, A., Mathew, M., (2019): Solar photovoltaic tree and its end-of-life management using thermal and chemical treatments for material recovery. *Case Stud. Therm. Eng.* 14, 100474. <https://doi.org/10.1016/j.csite.2019.100474>
56. Gangwar, P., Singh, R., Tripathi, R.P., Singh, A.K., (2019): Effective solar power harnessing using a few novel solar tree designs and their performance assessment. *Energy Sources, Part A Recover. Util. Environ. Eff.* 41, 1828–1837. <https://doi.org/10.1080/15567036.2018.1549162>

57. Gangwar, P., Tripathi, R.P., Singh, A.K., (2021): Solar photovoltaic tree: a review of designs, performance, applications, and challenges. *Energy Sources, Part A Recover. Util. Environ. Eff.* 00, 1–28. <https://doi.org/10.1080/15567036.2021.1901802>
58. Gawad, A.A., (2021): Solar-Tree Model Based on Fibonacci-Sequence for Better Awareness of Solar Technology in Urban Environment solar-tree model based on fibonacci-sequence for better awareness of solar technology in urban environment.
59. Gupta, A.D., (2021): Experimental Investigation for photo-voltaic power generation using the concept of solar tree 0–4. <https://doi.org/10.13140/RG.2.2.35014.80960>
60. Gupta, S., (2017): Quantum solar tree- design and production for domestic applications and future trends 3, 439–444.
61. Gupta, U., 2022. Largest solar tree, <https://www.pv-magazine.com/2022/03/17/worlds-largest-solar-tree-record-smashed/>
62. Hammoumi, A. El, Motahhir, S., Ghzizal, A. El, Chalh, A., Derouich, A., (2018): A simple and low-cost active dual-axis solar tracker. *Energy Sci. Eng.* 6, 607–620. <https://doi.org/10.1002/ese3.236>
63. Hartner, M., Ortner, A., Hiesl, A., Haas, R., (2015): East to west - The optimal tilt angle and orientation of photovoltaic panels from an electricity system perspective. *Appl. Energy* 160, 94–107. <https://doi.org/10.1016/j.apenergy.2015.08.097>
64. Hayat, M.B., Ali, D., Monyake, K.C., Alagha, L., Ahmed, N., (2019): Solar energy—A look into power generation, challenges, and a solar-powered future. *Int. J. Energy Res.* 43, 1049–1067. <https://doi.org/10.1002/er.4252>
65. Hirani, H., (2020): world largest solar tree. *CIOReviewIndia*. <https://www.cioreviewindia.com/news/world-s-largest-solar-tree-is-being-developed-by-csircmeri-nid-5810-cid-64.html>
66. Hjälml, (2020): Environment. URL <https://ec.europa.eu/environment/europeangreencapital/news/events/energy-tree-launch-event/index.html>
67. Holman, J.P., (2018): *Experimental methods for engineers*, Eighth edi. ed, Models for Deriving Cultural Information from Stone Tools. New York. <https://doi.org/10.2307/j.ctv16r1d.9>
68. Hyder, F., Baredar, P., Sudhakar, K., (2018): A novel Sun tracking technique through a Solar PV Tree and a smart controller. *Proc. 4th Int. Conf. Electr. Energy Syst. ICEES 2018* 407–411. <https://doi.org/10.1109/ICEES.2018.8443263>
69. Hyder, F., Baredar, P., Sudhakar, K., Mamat, R., (2018): Performance and land footprint analysis of a solar photovoltaic tree. *J. Clean. Prod.* 187, 432–448. <https://doi.org/10.1016/j.jclepro.2018.03.249>
70. Hyder, F., Sudhakar, K., Mamat, R., (2018): Solar PV tree design: A review. *Renew. Sustain. Energy Rev.* 82, 1079–1096. <https://doi.org/10.1016/j.rser.2017.09.025>
71. IndiaMART, (2019): Solar Tree. <https://www.indiamart.com/proddetail/solar-tree-16235981391.html>.
72. Ishaq, M., Ibrahim, U.H., (2013): Design Of An Off Grid Photovoltaic System: A Case Study Of Government Technical College, Wudil, Kano State. *Int. J. Sci. Technol. Res.* 2, 175–181.

73. Jain, S., Verma, N., (2019): State of art technologies in agriculture and recommendation to improve farmer's economy through solar tree concept. AKS University, Satna.
74. JAVAID, A., (2020): CSIR-CMERI developed world's largest solar tree. <https://www.jagranjosh.com/general-knowledge/worlds-largest-solar-tree-developed-by-csir-cmeri-1599722067-1>
75. Jean, J., Brown, P.R., Jaffe, R.L., Buonassisi, T., Bulović, V., (2015): Pathways for solar photovoltaics. *Energy Environ. Sci.* 8, 1200–1219. <https://doi.org/10.1039/c4ee04073b>
76. Jessen, W., Wilbert, S., Gueymard, C.A., Polo, J., Bian, Z., Driesse, A., Habte, A., Marzo, A., Armstrong, P.R., Vignola, F., Ramírez, L., (2018): Proposal and evaluation of subordinate standard solar irradiance spectra for applications in solar energy systems. *Sol. Energy* 168, 30–43. <https://doi.org/https://doi.org/10.1016/j.solener.2018.03.043>
77. Jincy, J., Bhaskar, Padigala Divya, J., Gaurav , Dahal Suchismita, M., T.S., P., Shruti, R., (2015): Report 2015. India.
78. Jordehi, A.R., (2016): Parameter estimation of solar photovoltaic (PV) cells: A review. *Renew. Sustain. Energy Rev.* 61, 354–371. <https://doi.org/10.1016/j.rser.2016.03.049>
79. Kafui, A.D., Seres, I., Farkas, I., (2019): Efficiency comparison of different photovoltaic modules. *Acta Technol. Agric.* 22, 5–11. <https://doi.org/10.2478/ata-2019-0002>
80. Kesler, S., Kivrak, S., Dincer, F., Rustemli, S., Karaaslan, M., Unal, E., Erdiven, U., (2014): The analysis of PV power potential and system installation in Manavgat, Turkey - A case study in winter season. *Renew. Sustain. Energy Rev.* 31, 671–680. <https://doi.org/10.1016/j.rser.2013.12.027>
81. Khare, V., Chaturvedi, P., Mishra, M., (2023): Solar energy system concept change from trending technology: A comprehensive review. *e-Prime - Adv. Electr. Eng. Electron. Energy* 4, 100183. <https://doi.org/https://doi.org/10.1016/j.prime.2023.100183>
82. Kim, K., Kim, Y., (2015): Role of policy in innovation and international trade of renewable energy technology: Empirical study of solar PV and wind power technology. *Renew. Sustain. Energy Rev.* 44, 717–727. <https://doi.org/10.1016/j.rser.2015.01.033>
83. Kim, S., Quy, H. Van, Bark, C.W., (2021): Photovoltaic technologies for flexible solar cells: beyond silicon. *Mater. Today Energy* 19, 100583. <https://doi.org/10.1016/j.mtener.2020.100583>
84. Kumar, B., Szepesi, G., Čonka, Z., Kolcun, M., Péter, Z., Berényi, L., Szamosi, Z., (2021): Trendline assessment of solar energy potential in hungary and current scenario of renewable energy in the visegrád countries for future sustainability. *Sustain.* 13. <https://doi.org/10.3390/su13105462>
85. Kumar, M., Kumar, Akash, Kumar, Abhishek, Ranjan, A., Kumar, Ajit, (2019): Design and Fabrication of Solar tree. *Invertis J. Renew. Energy* 9, 21. <https://doi.org/10.5958/2454-7611.2019.00005.5>

86. Kumar, M., Rana, L., Pattnaik, A., (2021): Solar Tree – A Sustainable Energy Approach for Farmers. *J. Univ. Shanghai Sci. Technol.* 23, 410–419. <https://doi.org/10.51201/jusst/21/07150>
87. Kumar, N.M., Chopra, S.S., Malvoni, M., Elavarasan, R.M., Das, N., (2020): Solar cell technology selection for a PV leaf based on energy and sustainability indicators—A case of a multilayered solar photovoltaic tree. *Energies* 13, 6439. <https://doi.org/10.3390/en13236439>
88. Kumar, N.M., Ghosh, A., Chopra, S.S., (2020): Power Resilience Enhancement of a Residential Electricity User Using Photovoltaics and a Battery. *Energies* 13, 1–27.
89. Kumar, R., Bansal, K., Kumar, A., Yadav, J., Gupta, M.K., Singh, V.K., (2022): Renewable energy adoption: Design, development, and assessment of solar tree for the mountainous region. *Int. J. Energy Res.* 46, 743–759. <https://doi.org/10.1002/er.7197>
90. Kumar, R., Kumar, A., Gupta, M.K., Yadav, J., Jain, A., (2022): Solar tree-based water pumping for assured irrigation in sustainable Indian agriculture environment. *Sustain. Prod. Consum.* 33, 15–27. <https://doi.org/10.1016/j.spc.2022.06.013>
91. Kumari, N., Kumar Singh, S., Kumar, S., (2022): A comparative study of different materials used for solar photovoltaics technology. *Mater. Today Proc.* 66, 3522–3528. <https://doi.org/https://doi.org/10.1016/j.matpr.2022.06.403>
92. Ldata, G., (2019): Global solar photovoltaic capacity expected. <https://www.globaldata.com/global-solar-photovoltaic-capacity-expected-to-exceed-1500gw-by-2030-says-globaldata/>
93. Lingayat, A.B., Chandramohan, V.P., Raju, V.R.K., Meda, V., (2020): A review on indirect type solar dryers for agricultural crops – Dryer setup, its performance, energy storage and important highlights. *Appl. Energy* 258, 114005. <https://doi.org/10.1016/j.apenergy.2019.114005>
94. Liu, H., Chen, C., Chen, G., Kuang, Y., Zhao, X., Song, J., Jia, C., Xu, X., Hitz, E., Xie, H., Wang, S., Jiang, F., Li, T., Li, Y., Gong, A., Yang, R., Das, S., Hu, L., (2018): High-Performance Solar Steam Device with Layered Channels: Artificial Tree with a Reversed Design. *Adv. Energy Mater.* 8, 1–8. <https://doi.org/10.1002/aenm.201701616>
95. Liu, S., Tang, Z.R., Sun, Y., Colmenares, J.C., Xu, Y.J., (2015): One-dimension-based spatially ordered architectures for solar energy conversion. *Chem. Soc. Rev.* 44, 5053–5075. <https://doi.org/10.1039/c4cs00408f>
96. Lu, Y., Khan, Z.A., Alvarez-Alvarado, M.S., Zhang, Y., Huang, Z., Imran, M., (2020): A Critical Review of Sustainable Energy Policies for the Promotion of Renewable Energy Sources. *Sustainability* 12. <https://doi.org/10.3390/su12125078>
97. Ma, Q., Zhang, Y., Wu, G., Yang, Q., Yuan, Y., Cheng, R., Tong, Y., Fang, H., (2022): Photovoltaic/spectrum performance analysis of a multifunctional solid spectral splitting covering for passive solar greenhouse roof. *Energy Convers. Manag.* 251, 114955. <https://doi.org/10.1016/j.enconman.2021.114955>
98. Mathews, I., Kantareddy, S.N., Buonassisi, T., Peters, I.M., (2019): Technology and Market Perspective for Indoor Photovoltaic Cells. *Joule* 3, 1415–1426. <https://doi.org/10.1016/j.joule.2019.03.026>

99. Mekhilef, S., Saidur, R., Safari, A., Mustaffa, W.E.S.B., (2011): Biomass energy in Malaysia: Current state and prospects. *Renew. Sustain. Energy Rev.* 15, 3360–3370. <https://doi.org/10.1016/j.rser.2011.04.016>
100. Mohammad Bagher, A., (2015): Types of Solar Cells and Application. *Am. J. Opt. Photonics* 3, 94. <https://doi.org/10.11648/j.ajop.20150305.17>
101. Muminovic, A., Pervan, N., Tasić, P., Avdic, V., Muminovic, A., Pervan, N., Tasic, P., Zecevic, S., (2013): Implementation of the Project “Solar tree” in Sarajevo. *Conf. Green Des. Conf. Sarajev. Bosnia Herzegovina, VOL.2.*
102. NAIR, R., (2020): India develops largest solar tree. <https://mercomindia.com/india-develops-largest-solar-tree/>
103. Nwaigwe, K.N., Mutabilwa, P., Dintwa, E., (2019): An overview of solar power (PV systems) integration into electricity grids. *Mater. Sci. Energy Technol.* 2, 629–633. <https://doi.org/10.1016/j.mset.2019.07.002>
104. O’Keefe, F., (2015): Suntan around these badass solar palm trees in Dubai. <https://www.greenprophet.com/2015/11/solar-palm-trees-3d-printed-dubai/>
105. Oluwafemi, I., Laseinde, T., Salau, A.O., (2019): Design and Construction of a 0.5 kW Solar Tree for Powering Farm Settlements. *Int. J. Mech. Eng. Technol.* 10, 19–33.
106. Parida, B., Iniyana, S., Goic, R., (2011): A review of solar photovoltaic technologies. *Renew. Sustain. Energy Rev.* 15, 1625–1636. <https://doi.org/10.1016/j.rser.2010.11.032>
107. Patil, R.K., (2018): Solar Tree-Working Principle , Arrangements- A Study. *Int. J. Creat. Res. Thoughts* 6, 291–295.
108. Slooff, L. H., van Roosmalen, J. A. M., Okel, L. A. G., de Vries, T., Minderhoud, T., Gijzen, G., Sepers, T., Versluis, A., Frumau, F., Rietbergen, M., Polinder, L., Heller, E. M. B., & de Vries, F. (2017): An Architectural Approach for Improving Aesthetics of PV. In *Proceedings of 33rd European PV Solar Energy Conference and Exhibition ECN Solar Energy.*
109. Perry, T., (2019): acre eco-tourism project. Tod Perry. <https://www.upworthy.com/magnificent-solar-powered-supertrees-are-the-highlight-of-singapores-new-250-acre-eco-tourism-project>
110. Piotrowski, L.J., Farret, F.A., (2022): Feasibility of solar tracking and fixed topologies considering the estimated degradation and performance of photovoltaic panels. *Sol. Energy Mater. Sol. Cells* 244, 111834. <https://doi.org/10.1016/j.solmat.2022.111834>
111. Prakash, S., Department, E., Priya, Ss., Scholar, P., -bist, B., (2020): Design, Analysis and Real Time Implementation of Solar Tree in Bihar 21, 8–12.
112. Prasad, A.K., Maity, A., Mandal, S.K., Mosan, S., (2018): Estimation of Energy from the Developed Solar Artifact, *Mechanical Engineering*, 125, 52369–52372.
113. Praveenkumar, S., Gulakhmadov, A., Agyekum, E.B., Alwan, N.T., Velkin, V.I., Sharipov, P., Safaraliev, M., Chen, X., (2022): Experimental study on performance enhancement of a photovoltaic module incorporated with CPU heat pipe — A 5E analysis. *Sensors* 22, 6367. <https://doi.org/https://doi.org/10.3390/s22176367>

114. Prize, L., Bellew, P., Freng, R.D.I., Ten, Ingenia, A., 2014. Sustainability.
115. Rajae, M., Jalali, M., (2022): Analysis and implementation of the solar tree by determining the optimal angle in Shiraz-Iran. *J. Comput. Appl. Res. Mech. Eng.* 12, 95–107. <https://doi.org/10.22061/jcarme.2021.8079.2076>
116. Rajae, M., Jalali, M., (2021): Analysis and implementation of the solar tree by determining the optimal angle in Shiraz-Iran. *J. Comput. Appl. Res. Mech. Eng.* x. <https://doi.org/10.22061/jcarme.2019.4665.xxxx>
117. Ramanujam, J., Bishop, D.M., Todorov, T.K., Gunawan, O., Rath, J., Nekovei, R., Artegiani, E., Romeo, A., (2020): Flexible CIGS, CdTe and a-Si:H based thin film solar cells: A review. *Prog. Mater. Sci.* 110, 1–20. <https://doi.org/10.1016/j.pmatsci.2019.100619>
118. Rangarajan, S.S., Collins, E.R., Fox, J.C., (2019): Efficacy of a Smart Photovoltaic inverter as a virtual detuner for mitigating Network Harmonic Resonance in Distribution Systems. *Electr. Power Syst. Res.* 171, 175–184. <https://doi.org/10.1016/j.epsr.2019.02.001>
119. Rawat, N., Vidhyarthi, V., Awasthi, N., (2017): Solar tree: New Proposed Model For Harnessing Solar Energy And Its Scope In India 8, 407–410.
120. Renugadevi, V., (2017): An approach to solar power tree. *Proc. - 2017 IEEE Int. Conf. Electr. Instrum. Commun. Eng. ICEICE 2017, Decem,* 1–3. <https://doi.org/10.1109/ICEICE.2017.8191921>
121. Shanmukhi, K., Rajeev Kumar, J., Siva Prasad, N.V.S.S., Naidu, M.K., Srinivasa Rao, S., (2019): Design and Analysis on Structure of a Solar Tree for 3 kW Capacity. Springer Singapore. https://doi.org/10.1007/978-981-13-7643-6_60
122. Sheppard, C., (2013): Gardens By the Bay, Istructe structural awards 2013 Singapore 1–7.
123. Shukla, A., Kant, K., Sharma, A., Biwole, P.H., (2017): Cooling methodologies of photovoltaic module for enhancing electrical efficiency: A review. *Sol. Energy Mater. Sol. Cells* 160, 275–286. <https://doi.org/10.1016/j.solmat.2016.10.047>
124. Shukla, A.K., Sudhakar, K., Baredar, P., (2017): Renewable energy resources in South Asian countries: Challenges, policy and recommendations. *Resour. Technol.* 3, 342–346. <https://doi.org/10.1016/j.reffit.2016.12.003>
125. Shukla, A.K., Sudhakar, K., Baredar, P., (2016): Design, simulation and economic analysis of standalone roof top solar PV system in India. *Sol. Energy* 136, 437–449. <https://doi.org/10.1016/j.solener.2016.07.009>
126. Singh, J., Agrahari, A., (2019): The progression of silicon technology acting as substratum for the betterment of future photovoltaics. *Int. J. Energy Res.* 43, 3959–3980. <https://doi.org/10.1002/er.4402>
127. Singh, R., Rawat, N., Srivastava, R., (2019): Performance Evaluation of a Solar Tree Design and a Fixed Solar Panel for Effective Solar Power Harnessing. *International Journal of Applied Engineering Research.* 14, 2616–2621.
128. Solar Panels in Palm, (2016): <https://www.energysage.com/local-data/solar-panel-cost/fl/brevard-county/palm-bay/>

129. Solaripedia, (2014): Solar Trees in City Gardens (Singapore). solaripedia. https://www.solaripedia.com/13/416/6633/solar_supertrees_architectural_drawing.html
130. Sredenšek, K., Štumberger, B., Hadžiselimović, M., Mavsar, P., Seme, S., (2021): Physical, Geographical, Technical, and Economic Potential for the Optimal Configuration of Photovoltaic Systems Using a Digital Surface Model and Optimization Method. SSRN Electron. J. 242. <https://doi.org/10.2139/ssrn.3892172>
131. Srisai, S., Harnsoongnoen, S., (2019): Efficiency of solar tree based on golden ratio. J. Phys. Conf. Ser. 1380. <https://doi.org/10.1088/1742-6596/1380/1/012025>
132. Tooby, J., Cosmides, L., (2001): Does Beauty Build Adapted Minds? Toward an Evolutionary Theory of Aesthetics, Fiction, and the Arts. *SubStance* 30, 6–27. <https://doi.org/10.1353/sub.2001.0017>
133. Torgal, S., (2016): Concept of Solar Power Tree. *Int. Adv. Res. J. Sci. Eng. Technol.* 3, 2393–2395. <https://doi.org/10.17148/IARJSET.2016.3440>
134. U. Hassan, M., Saha, S., Haque, M.E., (2021): A framework for the performance evaluation of household rooftop solar battery systems. *Int. J. Electr. Power Energy Syst.* 125, 106446. <https://doi.org/10.1016/j.ijepes.2020.106446>
135. Vardhan, H., (2016): Solar power tree, Science and technology. <https://dst.gov.in/pressrelease/dr-harsh-varadhan-launches-‘solar-power-tree’---innovation-aimed-utilizing-minimum-land>
136. Verma, N.N., Mazumder, S., (2014): An investigation of solar trees for effective sunlight capture using Monte Carlo simulations of solar radiation transport. *ASME Int. Mech. Eng. Congr. Expo. Proc.* 8A, 1–10. <https://doi.org/10.1115/IMECE2014-36085>
137. Vyas, M., Chowdhury, S., Verma, A., Jain, V.K., (2022): Solar Photovoltaic Tree: Urban PV power plants to increase power to land occupancy ratio. *Renew. Energy* 190, 283–293. <https://doi.org/https://doi.org/10.1016/j.renene.2022.03.129>
138. Wang, F., Xuan, Z., Zhen, Z., Li, K., Wang, T., Shi, M., (2020): A day-ahead PV power forecasting method based on LSTM-RNN model and time correlation modification under partial daily pattern prediction framework. *Energy Convers. Manag.* 212, 112766. <https://doi.org/https://doi.org/10.1016/j.enconman.2020.112766>
139. Wen, Q., Liu, G., Rao, Z., Liao, S., (2020): Applications, evaluations and supportive strategies of distributed energy systems: A review. *Energy Build.* 225, 110314. <https://doi.org/10.1016/j.enbuild.2020.110314>
140. Yahyaoui, I., (2018): *Advances in Renewable Energies and Power Technologies*, 1st ed. Elsevier, Madrid, Spain.
141. Yunus Khan, T.M., Soudagar, M.E.M., Kanchan, M., Afzal, A., Banapurmath, N.R., Akram, N., Mane, S.D., Shahapurkar, K., (2020): Optimum location and influence of tilt angle on performance of solar PV panels. *J. Therm. Anal. Calorim.* 141, 511–532. <https://doi.org/10.1007/s10973-019-09089-5>
142. Zomer, C., Custódio, I., Goulart, S., Mantelli, S., Martins, G., Campos, R., Pinto, G., Rüther, R., (2020): Energy balance and performance assessment of PV systems

- installed at a positive-energy building (PEB) solar energy research centre. *Sol. Energy* 212, 258–274. <https://doi.org/10.1016/j.solener.2020.10.080>
143. Zsiborács, H., Bai, A., Popp, J., Gabnai, Z., Pályi, B., Farkas, I., Baranyai, N.H., Veszelka, M., Zentkó, L., Pintér, G., (2018): Change of Real and Simulated Energy Production of Certain Photovoltaic Technologies in Relation to Orientation, Tilt Angle and Dual-Axis Sun-Tracking. A Case Study in Hungary. *Sustainability* 10. <https://doi.org/10.3390/su10051394>
144. Zubi, G., Adhikari, R.S., Sánchez, N.E., Acuña-Bravo, W., (2020): Lithium-ion battery-packs for solar home systems: Layout, cost and implementation perspectives. *J. Energy Storage* 32. <https://doi.org/10.1016/j.est.2020.101985>

A2: Publications related to the dissertation*Refereed papers in foreign languages:*

1. **Almadhhachi M.**, Seres I., Farkas I. (2020): Concept of a solar cell operated hybrid tree, *Mechanical Engineering Letters*, 20, 96–100.
https://www.gek.szie.hu/english/sites/default/files/MEL_2020_20.pdf
2. **Almadhhachi M.**, Seres I., Farkas I. (2022): Comparison of the efficiency of polycrystalline and thin-film photovoltaic outdoors, *European Journal of Energy Research*. 2, 9–12. <https://doi.org/10.24018/ejenergy.2022.2.2.43>
3. **Almadhhachi M.**, Seres I., Farkas I. (2022): Significance of solar trees: Configuration, operation, types and technology commercialization, *Energy Reports*. 8, 6729–6743. <https://doi.org/10.1016/j.egy.2022.05.015> (Scopus: Q1, IF = 5.2)
4. **Almadhhachi M.**, Seres I., Farkas I. (2023): Electrical power harvesting enhancement of PV module by a novel hemispherical configuration, *International Journal of Thermofluids*. 20, 100460 <https://doi.org/10.1016/j.ijft.2023.100460> (Scopus: D1)
5. **Almadhhachi M.**, Seres I., Farkas I. (2024): Sunflower solar trees vs. flat PV modules: A comprehensive analysis of performance, efficiency, and land savings in urban solar integration, *Results in Engineering*, 21. 101742. <https://doi.org/10.1016/j.rineng.2023.101742> (Scopus: Q1, IF = 5)
6. **Almadhhachi M.**, Seres I., Farkas I. (2024): Harnessing solar power with aesthetic innovation: An in-depth study on spherical and hemispherical photovoltaic configurations, *Energy Science and Engineering*, <https://doi.org/10.1002/ese3.1717> (Scopus: Q2, IF = 3.8)

International conference abstracts

7. **Almadhhachi M.**, Seres I., Farkas I. (2020): Designing a hybrid tree by a combination between black body and solar cells, *Book of Abstracts, 26th Workshop on Energy and Environment, Gödöllő, Hungary, December 10-11, 2020*, p. 12, ISBN 978-963-269-928-8.
8. **Almadhhachi M.**, Seres I., Farkas I. (2021): Materials of a solar cell operated hybrid tree, *Book of abstracts, BioPhys Spring 2021: 20th International Workshop for Young Scientists, Lublin, Poland, May 18, 2021*, p. 16, ISBN 978-83-89969-68-6.
9. **Almadhhachi M.**, Seres I., Farkas I. (2021): Efficiency comparison between the polycrystalline and thin-film PV modules, *Book of abstracts, 27th Workshop on Energy and Environment, Gödöllő, Hungary, December 9-10, 2021*, p. 10, ISBN 978-963-269-972-1.
10. **Almadhhachi M.**, Seres I., Farkas I. (2022): The importance of thin-film PV modules in building integrated design, *Book of abstracts, BioPhys Spring 2022: 21th International Workshop for Young Scientists, Nitra, Slovakia, May 30-31, 2022*, p. 14. ISBN 978-83-89969-74-3.
11. **Almadhhachi M.**, Seres I., Farkas I. (2022): Hemispherical shape solar tracking system without any machinery, *Book of Abstracts, 28th Workshop on Energy and Environment, Gödöllő, Hungary, December 8-9, 2022*, p. 10. ISBN 978-963-623-016-6.
12. **Almadhhachi M.**, Seres I., Farkas I. (2023): Productivity enhancement PV module based on solar tree, *Book of abstracts, BioPhys Spring 2023, Gödöllő, Hungary, Jun 15-16, 2023*, p. 15. ISBN 978-963-623-054-8.

13. **Almadhhachi M.**, Seres I., Farkas I. (2023): Shaping the future of solar: Evaluating the potential of spherical and hemispherical photovoltaic modules, Book of Abstracts, 29th Workshop on Energy and Environment, Gödöllő, Hungary, December 7-8, 2023, p. 19. ISBN 978-963-623-079-1.

9. ACKNOWLEDGEMENT

This thesis work was supported financially by the Stipendium Hungaricum Scholarship Program and the Mechanical Engineering Doctoral School at the Hungarian University of Agriculture and Life Sciences (MATE), Gödöllő, Hungary.

First of all, I would like to praise the Almighty God, who has granted me countless blessings and guidance during my studies.

I would like to express my deepest gratitude to my supervisors, Prof. Istvan Farkas and Dr Istvan Seres, for their inestimable guidance, consistent encouragement and support. Their thoughtful suggestions and ideas were vital for the framework and outcome of this research. It has been a rewarding experience for me to work with them all these years, and without them, this thesis would not have materialized. I was indeed privileged to have been under your supervision.

I am very grateful to my beloved wife and all other family members for their immeasurable love and sacrifices that made this feat possible.

I wish to acknowledge the Ministry of Higher Education of Iraq and my home university, the University of Kufa, for nominating and supporting me during my studies.

Finally, I would like to thank the Doctoral School of Mechanical Engineering staff and the University administration staff for their kindness and cooperation with me during my stay at the University.

Thank you for supporting and guiding me to where I am now. May the Almighty God continue to bless each and every one of you!

Gödöllő, January 2024

Mensour Almadhhachi