



HUNGARIAN UNIVERSITY OF
AGRICULTURE AND LIFE SCIENCES

HUNGARIAN UNIVERSITY OF AGRICULTURE AND LIFE SCIENCES

**PERFORMANCE MANAGEMENT SYSTEM (PMS) AND EMPLOYEE
ENGAGEMENT AND PRODUCTIVITY IN HOTELS: EVIDENCE FROM AN
EMERGING ECONOMY**

Doctoral (PhD) Dissertation Thesis

Dolores Mensah Hervie (MRS.)

Gödöllő, Hungary

2024

Hungarian University of Agriculture and Life Sciences

Name of doctoral school: DOCTORAL SCHOOL OF ECONOMIC AND REGIONAL SCIENCES

Discipline: Management and Business Administration

Head: Prof. Dr. Zoltán BUJDOSÓ
Head of Doctoral School of Economic and Regional Sciences
Hungarian University of Agriculture and Life Sciences

Supervisor: Prof. Dr. Csaba Bálint ILLÉS, CSc
John von Neumann University

Approval by Head of Doctoral School

Approval by Supervisor

Contents

1. INTRODUCTION.....	4
1.1 Problem Statement	9
1.2 Objectives of the Study	12
1.3 Research Hypotheses.....	13
1.4 Model Framework Showing How PMS Influenced by both National and Organisational Cultures can lead to its successful implementation in the Hotel Industry in Ghana.....	14
2. MATERIALS AND METHODS.....	19
2.1 Overview of Study Area.....	19
2.2 Research Design.....	19
2.3 Data Collection Tools and Source, Population, Sample Size and Sampling Technique.....	20
2.4 Analysis of Data.....	21
3. RESULTS AND DISCUSSION	23
3.1 Quantitative Analysis.....	23
3.1.1 Demographic and Background Characteristics of Respondents.....	23
3.1.2 Categories of Hotels Studied.....	25
3.2 Measurement Models – Confirmatory Factor Analysis.....	25
3.3 Reliability and Validity of CFA.....	28
3.4 Structural Equation Models.....	29
3.5 Qualitative Findings.....	39
3.5.1 Demographic Representation of Research Respondent.....	39
3.5.2 Respondents' Perception and Practice of PMS in their Hotels.....	39
3.5.3 Challenges with the Implementation of PMS and Suggested Solutions.....	40
3.5.4 Integration of Specific National and Organisational Culture into PMS.....	42
3.5.5 Recommendation of PMS to Other Hotels and Why?.....	43
3.5.6 Underlying Factors that Influence the Relationship Between PMS, Employee Engagement and Productivity.....	44
4. CONCLUSION AND RECOMMENDATION	46
4.1 Conclusion	46
4.1.1 Proposal for Further Studies.....	47
4.2 Recommendations.....	48
5. NEW SCIENTIFIC RESULTS.....	50
6. REFERENCES.....	52
7. DISSERTATION-RELATED PUBLICATIONS BY AUTHOR.....	61

1. INTRODUCTION

This chapter gives the background to the study. It comprises the introduction of the topic, the study area's description, a statement of the problem, objectives, research questions, the hypotheses tested, the significance of the study and limitations.

Performance management system (PMS) has received a lot of attention in recent times when focusing on employee performance and development (Varma et al., 2023; Abane & Phinaitrup, 2020; Sisa, E. 2014). PMS helps in trailing and constantly measuring employee performance and enables organisations to monitor individual employees, teams and departments to ensure that they are working efficiently and effectively toward the strategic objective of the company. More so now that human resource management (HRM) is considered a strategic partner, it becomes necessary in the development of employee skills for enhanced productivity (Idrus et al., 2023; Abdussamad et al., 2022; Saeidi et al., 2022; Valecha, 2022). PMS structure is designed to improve employees and organisational performance by finding performance needs, providing continuous feedback, motivating and helping employees develop their careers. It also aims to build a strong organisational culture that would help shape the attitude of employees.

Aguinis (2019) defines performance management (PM) as a “continuous process of identifying, measuring and developing the performance of individuals and teams and aligning their performance with the strategic goals of the organisation.” This indicates that PM is an important instrument that could be used by organisations to upgrade the potential of employees and encourage them to work towards the achievement of the organisation’s strategic goals. As suggested by Mangipudi et al. (2019), the performance and success of every organisation are dependent on its ability to gauge and optimise the performance of its employees as a vital resource. Performance Management System (PMS) establishes an immediate link between organisational objectives and employee performance, making the employees’ impact on the organisation evident.

The primary objective of a PMS is to measure and improve individual performance which would influence the quality of delivery in an organisational as well as the overall effectiveness. It is designed to help in decision-making and development. In practice, information accrued through PMS is expected to guide policy-making processes and procedures, decision-making as well as management control systems (Ohemeng et al., 2018).

Mangipudi et al. (2019) again posited that employees are the key stakeholders in any organisation therefore, policies relating to performance management systems should focus on their development and benefits. Varma et al. (2008) indicate that many studies have shown that both PMS with its subset which is performance appraisal (PA) are fundamental duties of the human resource management function.

Otoo and Mishra (2018) state that human resources are regarded as organisation's most valuable asset that can influence its success and competitiveness, particularly, in a labour-intensive service industry like hotels where employees interact with guests directly. O'riordan, (2017), argued that programmes and policies relating to managing the workforce should be compatible with the comprehensive strategy of the organisation. Previous studies have shown that strategic human resource management practices impact positively employees' performance which advertently influences the organisation's performance (Boon et al., 2018; Collings et al., 2021; Sepahvand and Bagherzadeh, 2021). Saluy et al. (2021) indicate that productivity relates directly to performance and proposes that the level of productivity equates to the level of performance.

Studies have again revealed that most hotels in advanced countries and emerging economies practice performance management system. Some hotels in countries like Ireland, China, Indonesia, India, Ethiopia and Kenya practice (Bhatnagar et al., 2004; Chen et al., 2011; Makori, 2014; O'Donovan & Linehan, 2014; Meilani & Anugrah, 2015; Girma, 2016). However, the use of PMS in the hotel industry is very different from traditional industries. For instance, Hilton Hotel China started its performance management by allowing managers to establish a code of conduct that monitors the behaviour of employees to identify excellent and poor performance. It spells out the values of the hotel, strengthens and trains employees to appreciate the values and culture of the hotel. Through the same code, employees are also able to evaluate the effectiveness of management and managerial staff (Chen et al., 2011).

PMS originated in the US and has recorded several success stories in both advanced and developing countries. For instance, in a study by Development Dimensions International (DDI), 79% of the Chief Executive Officers (CEO) surveyed indicated that PMS deployed in their firms runs the 'cultural strategies that maximise human assets' (Aguinis, 2019). Although PMS is perceived as a tool for unearthing employee potential and achieving

organisational strategic objectives, studies have shown that its implementation and practice have been based on definite characteristics relating to countrywide perspectives and culture. The cultural variations make it difficult to apply certain aspects of the concept uniformly across countries (Kichigina, 2017). Some of the contextual elements that influence the execution of PMS in a country are culture and belief system, the role of human resource, increasing customer demands, leadership behaviour, level of technological advancement, increasing competition, change in consumer behaviour etc. (Jelínková, 2017; Rusu et al. 2016).

Based on the preceding argument, it is necessary to adopt a performance management system that would factor in the Ghanaian as well as organisational cultural systems that would suit the hospitality industry to ensure success in its implementation and practice. As recommended by Boella and Goss-Turner (2020) human resource management (HRM) in hotels must adopt and implement policies and practices that would unleash the abilities and commitments of persons and teams toward their respective jobs and enhance their performance. The hotel industry was chosen because it is an industry in the service sector where employees are always in direct contact with guests. More so, hotels in Ghana suffer high employee turnover like other countries due to the influx of multinational hotels particularly in Accra, low salaries and low-skilled jobs (Deri et al., 2021). HR practices that would sustain and motivate employees remain vital to this sub-sector. A study by (Boadu et al. (2014) suggest that most hotels in the Ashanti Region of Ghana practice performance appraisal. Even those who evaluated their employees did not give them feedback and the employees did not understand the whole process. In another study to evaluate performance appraisal in small and medium hotels in the Central Ayawaso Metropolitan Area of the Greater Accra Region of Ghana, with a response from sixty managers, it was revealed that most (58.7%) of the hotels appraised their employees daily through individual employee discussion. The outcome of the appraisal was used in determining training needs. It also became known that while 70% of the managers preferred to support non-performing employees, 30% would rather terminate their employment (Oduro-Nyarko, 2013). Brown (2019) referred to Performance Appraisal as “a formal process in which the performance of an individual is evaluated by the supervisor over a period of time, traditionally one year.” Another study conducted by Jain and Gautam (2014) also specifies that most organisations are less inclined to adopt PMS. They, however, practiced basic HR functions like recruitment and selection, training and development, compensation and reward. Additionally, Chowdhury

(2011), who conducted a study of several local and private organisations in Bangladesh found out that most of the organisations practiced different types of PMS, and some of them were not effective to bring any positive change in the organisational growth. All of these point to the importance of implementing a PMS that has to consider a countrywide perspective.

Hotels are likewise increasing precipitously in reaction to the growing tourist trade and the openings presented by pragmatic macroeconomic strategies. The majority of its patronage are international tourists and investors who come to Ghana for possible investments, conferences and training. In addition, the burgeoning middle-income group in Ghana is also patronising the services of these hotels (Hervie et al., 2020).

The hospitality industry comprises hotels, tourism, food and beverages (Hospitality Industry in Ghana, 2020). The Bank of Ghana (Central Bank) records this industry as the 4th highest overseas exchange earner apart from remittances, gold and cocoa in 2017. That same year, the industry added USD 2.7 billion (6.2%) to the national GDP (Oxford Business Group Economic Report, 2019). A sum of 1.3 million international travellers visited Ghana during the same year, indicating a 6% rise compared to 2016. With regards to employment, the World Travel and Tourism Council reported that tourism supported 682,000 employments, which was 5.3% of total national employment, in 2017. According to the International Finance Corporation Report (2016), hotels contribute significantly to the gross domestic product (GDP) of the country. For example, in 2014, Mövenpick Hotel, one of the biggest hotels in the country's capital, Accra, contributed a little below \$24 million to Ghana's GDP and \$2.4 million in taxes. The hotel also acts as a training hub for its numerous employees who acquire important employable skills in addition to soft skills. Hotels and restaurants in Ghana contributed USD 985.8 million to its GDP in 2019. However, this was reduced to USD 640.9 million in 2020, which may be due to the impact of the COVID-19 pandemic on the sector (Sasu, 2021). The report again revealed that hotels promoted domestic economic activities through guests' spending especially, visitors who consume goods and services beyond the hotel and contribute to other local companies and transport. Furthermore, hotels create and sustain a large number of employment, particularly auxiliary and induced jobs through the procuring of goods and services. For instance, even in 2021 when the hotels were recovering from the COVID-19 pandemic shock, the subsector, contributed 525.3 thousand towards employment in Ghana (Sasu, 2022).

Due to the impact that hotels have on economies, it is expedient that hotels in Ghana adopt a performance management system to leverage employee performance with organisational culture and strategy. More so, PMS does not only assist top management to achieve strategic business objectives but also helps employees develop and grow (Aguinis, 2019).

Despite the immense contribution of the hospitality industry, it remains susceptible to the frequent rate of natural disasters and pandemics (Dube et al., 2020). The declaration of the novel coronavirus as a pandemic on March 11, 2020, by the World Health Organisation (WHO), led to the closure of airports, travel restrictions, the shutdown of restaurants, amusement parks, cinemas, casinos, hotels and its major events brought an abrupt fall in revenue and occupancy in the industry globally and the end is still unforeseeable. For instance, revenue per available room in the industry fell by over 66.2% in March and cascaded downwards to 95% in April 2020, in the European hotel industry when COVID-19 started spreading (Statista, 2020). The occupancy rates in the Middle East dropped from 73.3% (with a daily rate of US149) in January 2019 to 47.3% (with a daily rate of US121) in June 2019, which declined further year-on-year to 28% and 17% separately in 2020 (Deloitte, 2020). The impact of COVID-19 is no different in Africa. For example, in South Africa, the most hit country in Africa, 69% of businesses in the industry had to close down temporarily, 58% downsized, 50% of hotels had to reduce the wages of about half of their employees and 36% had to reduce the wages of all their employees (Rogerson & Rogerson, 2020). In Ghana, three days after the president, H.E. Nana Akufo Addo announced measures to control the spread of the coronavirus, patronage in the tourism and hospitality industry dropped to about 60%. It declined further to about 80% causing some players in the industry to fold up or shut down portions of their operations (Thams et al., 2020). Over 50% of employees were laid off in this industry and the occupancy rate was reduced to less than 30%.

According to Hospitality and Tourism International (HTI) Consulting (2017), Accra has been a major engine of growth in the African hospitality market. The hospitality market in Accra started accelerating after the discovery of oil and gas, as well as a stable political climate, an increase in foreign direct investment and economic growth experienced in the entire country. For instance, between 2010 and 2015, the sector saw an increase of nearly 1400 quality rooms in hotels compared to 545 between 2000 and 2009. With this background, it is very

pertinent that hotels consider the continuous improvement of the employees' performance for competitive advantage.

The purpose of this research is to examine the types of performance appraisal tools used in the hotels, if some are practicing PMS, how it is done as well as the Ghanaian (national) and organisational cultures that would help in the effective implementation of a performance management system to improve employee engagement and productivity.

1.1 Problem Statement

The hospitality industry is one of the fastest-growing industries in the world. International chains of hotels are establishing their presence in many countries across the globe particularly, in emerging and developing countries (Boella and Goss-Turner, 2020). For instance, Mövenpick, Holiday Inn, Golden Tulip, Best Western Premier, Kempinski Gold Coast, Accra City and Ibis Hotels have found their way into Ghana. This influences the demand for human resources and practices because these international hotels require employees whose potential and competencies can be harnessed to meet today's requirements in the tourism and hospitality industry as well as contribute to the success of the hotels. Hence, the call for effective and efficient management of human resources (Boella and Goss-Turner, 2020). Performance management system is one such HR practice that aligns employees' goals to the organisations to achieve a competitive edge.

Studies have shown that most hotels in developed, and some emerging economies have adopted PMS. Examples are Ireland, China, Indonesia, India, Ethiopia and Kenya practice PMS (Meilani & Anugrah, 2015; O'Donovan & Linehan, 2014; Chen et al., 2011; Raj & Verma, 2020; Makori, 2014; Girma, 2016). Although some developed countries such as the US and Europe have chalked successes in the implementation of PMS, their practices have been met with some challenges and failures (Kaupa & Atiku, 2020; Sisa, 2014).

PMS is a tool for unearthing employee potential and achieving organisational strategic objectives. Research shows that its implementation and practice are characterised by countrywide perspectives and culture (Plaček et al., 2020; Cho & Payne, 2016). The cultural variations make it difficult to apply certain aspects of the concept uniformly across countries (Kichigina, 2017). In a study to examine the relationship between public sector reforms and culture in Bhuta, Ugyel (2021) saw culture as a crucial element that impacts the

implementation of performance management reforms in the public sector. The study revealed two key cultural issues that affect the implementation of PMS. These are (1) agreement or opposition to change during a reformation process, and (2) the foundational challenges that go with implementing new public management-associated PMS in socialist countries because of their collective culture. The study further showed that senior officials in the civil service resisted previous reforms due to cultural changes that were not addressed in the design and implementation of the performance management reforms. Anh Vu et al. (2022) stated that employee performance management is often affected by both national and organisational cultural dimensions such as collectivity/individuality, uncertainty avoidance, job or employee-oriented cultures and process or results-oriented cultures. They asserted that designing an appraisal system that would be effective across diverse cultures would be problematic. This is consistent with the statement made by Kichigina (2017) that it would be challenging to apply the same aspects of PMS across countries due to cultural differences. Anh Vu et al. (2022) further posited that organisational culture like interpersonal relationships impedes performance management innovation. For instance, in both China and Vietnam, organisations where interpersonal relationship was valued, managers offered varying bonuses and promotion openings to subordinates based on the quality of relationships. It is argued that national culture has a great influence on the management of organisational cultures (Khan & Law, 2018). Malik et al. (2021) also support the fact that national culture influences organisational culture and vice versa, and both have an impact on employee performance. Their study examines the effect of human resource practices in the Indian cultural context and argues that the work culture and values of Indi-Pharmaco (a company under study) were corroborated by an important national culture known as “A guest is equivalent to God.” The study findings suggest that this concept influenced their organisational culture and values.

In Ghana, most hotels assess their employee performance through the traditional performance appraisal system. Some of the hotels do not have proper goal setting, organisational goals are not linked to individual goals, staff are not regularly trained, and decisions are taken from the top and implemented at the bottom. Low-performing employees were either encouraged to improve upon their performance or had their appointment terminated (Boadu et al., 2014). Unlike other organisations, hotels appraise their workers regularly because of the nature of their work although the assessment is not linked to the

overall objectives of the organisation. Boadu et al. (2014) again stated that most hotels did not have strategic plans that flow down to guide their activities. Their study revealed the extent to which performance appraisal was practiced in the hospitality industry in Ghana. Although a majority of the hotels practised performance appraisal, most managers and their subordinates did not understand the system, hence, necessary feedback was missing. Moreover, rewards were not measured based on performance. Hotel employees are not well-paid, leading to regular attrition, and the situation has worsened since the inception of the COVID-19 pandemic. The challenges linked to performance appraisal were also supported by Girma (2016) in Ethiopia. “Traditional” performance appraisal includes employees’ assessments once or twice a year with no continuing effort to provide important feedback and instructions or guidance for performance improvement. Appraisal only gives a systematic description of employees’ weaknesses and strengths. Also, performance appraisal practice generally does not involve all-encompassing and constant feedback that an employee could use to enhance their performance in the near future. Moreover, employees expect professional development activities in organisations, and where there is none, some may decide to quit. Hence, modern organisations are shifting more from the narrow focus of performance appraisal to a broader, comprehensive, and total performance management system of which performance appraisal forms an integral part (Pandita & Rays, 2018).

Further, during data collection, it came to light that some of the star-rated hotels (both local and international) practiced performance management system. However, there is no literature to support this claim. More than 80% of the literature on PMS in Ghana focused on the local governance environment (Abane & Brenya, 2021; Ahenkan et al., 2018; Bawole & Ibrahim, 2017).

It is against this background that this research seeks to examine the types of performance appraisal tools used in the hotels in Ghana and how the Ghanaian culture and organisational culture would influence the implementation of an effective performance management system in hotels in Ghana. A system that would motivate and enhance management as well as increase employee engagement and productivity which would in the long run lead to a competitive edge in employee delivery and strategic objective achievement.

Further, although literature has considered the six dimensions of national culture (Hofstede, 2011) Power Distance, Uncertainty Avoidance, Individualism/Collectivism, Masculinity/Femininity, Long/Short Term Orientation and Indulgence/Restraint, given the

cultural differences in Ghana, the national culture of Politeness and Hospitality has not been considered in the hotel subsector. Using foreign cultural contexts from Europe, America, Bhutan, India, or even African countries such as Kenya or Ethiopia to implement PMS in Ghana may not be successful due to cultural differences. This study would contribute to the literature by considering the implementation of PMS in the Ghanaian cultural context of Hospitality and Politeness.

Again, many corporate culture dimensions have been considered in literature (Hardiyanti et al., 2022; Akinlabi et al., 2021; Wang et al., 2021 & Sawalha et al., 2012). They include Interpersonal Relationships, Empowerment, Competence Development, Fair Rewards, Information Sharing, Trust, Competent, Harmonious, Loyal, Adaptive, Collaborative, Creation, Adhocracy, Clan, Market, and Hierarchy cultures. However, the last four dimensions (Adhocracy, Clan, Market, Hierarchy) are well-known across the globe. Although the culture of **Hierarchy** has been extensively studied, it has not been measured under human resource management in the hotel industry in Ghana. In addition to the **national culture of Politeness and Hospitality**, this study seeks to contribute to performance management literature by looking at how the Ghanaian **corporate culture of Hierarchy and Respect for the individual, supportive and experience** would assist in its effective implementation in the hotel industry.

1.2 Objectives of the Study

The primary objective of this study is to investigate appraisal systems being practised by hotels in Ghana, if some are practicing PMS, how it is done and consider the cultural factors that would help in the effective implementation of a performance management system to improve employee engagement and productivity.

To further contribute to the knowledge and understanding of the performance management system, the following secondary objectives have been set:

1. Investigate whether national and organisational cultures directly influence the relationship between effective PMS and employee engagement and productivity in hotels in the Greater Accra Region.
2. Investigate whether national and organisational cultures directly influence the relationship between Performance appraisal and employee engagement and productivity in hotels in the Greater Accra Region.

3. Investigate whether national and organisational cultures directly influence the relationship between selected HR practices and employee engagement and productivity in hotels in the Greater Accra Region.
4. Investigate whether national and organisational cultures would mediate the relationship between effective PMS and employee engagement and productivity in hotels in the Greater Accra Region.
5. Investigate whether national and organisational cultures would mediate the relationship between performance appraisal and employee engagement and productivity in hotels in the Greater Accra Region.
6. Investigate whether national and organisational cultures would mediate the relationship between selected HR practices and employee engagement and productivity in hotels in the Greater Accra Region.
7. To investigate if there are underlying factors that influence the relationships between performance management system, employee engagement and productivity.

1.3 Research Hypotheses

The research hypotheses were divided under two main items – national culture and organisational culture. Twelve hypotheses were tested for (i) Total and Direct Effects Model, and (ii) Mediation Model:

Total Effects Model for Organisational Culture

H1: Effective Performance Management System has a positive and significant relationship with Employee Engagement and Productivity.

H2: Performance Appraisal system has a positive and significant relationship with Employee Engagement and Productivity.

H3: Selected HR has a positive and significant relationship with Employee Engagement and Productivity.

Total Effects Model for National Culture

H4: Effective Performance Management System has a positive and significant relationship with Employee Engagement and Productivity.

H5: Performance Appraisal system has a positive and significant relationship with Employee Engagement and Productivity.

H6: Selected HR has a positive and significant relationship with Employee Engagement and Productivity.

Mediation Model for Organisational Culture

H7: Organisational Culture mediates the relationship between Effective Performance Management and Employee Engagement and Productivity.

H8: Organisational Culture mediates the relationship between Performance Appraisal and Employee Engagement and Productivity.

H9: Organisational Culture mediated the relationship between Selected HR practices and Employee Engagement and Productivity

Mediation Model for National Culture

H10: National Culture mediates the relationship between Effective Performance Management and Employee Engagement and Productivity.

H11: National Culture mediates the relationship between Performance Appraisal and Employee Engagement and Productivity.

H12: National Culture mediates the relationship between Selected HR practices and Employee Engagement and Productivity.

1.4 Model Conceptual Framework showing how performance management system influenced by both national and organisational culture can lead to its successful implementation in the hotel industry in Ghana.

This model conceptual framework (**Figure 1**) was developed based on literature. It is meant to elaborate on how performance management system, performance appraisal and selected HR practices in the hotel industry could be influenced by both national and organisational cultures, to result in employee engagement and productivity. Through this model conceptual framework, the study determines the correlation between the variables to ascertain whether they are positive and significantly related.

The mission and vision of the hotels indicate the reason for their existence and what they sought to achieve. Out of these two variables, the hotels would deduce and communicate their organisational culture, values and objectives, which must be adapted by the employees.

Strategic planning is an activity by the hotel management to set out priorities in terms of resource availability, establishing the overall organisational goals and the means to achieve them, and giving a sense of direction to ensure competitive advantage and success. The strategic plan which is generated during the planning stage is influenced by the core values, culture and other contextual factors like motivation, measurement and reward, and the role of HR in the organisation. It contains the important components developed during the planning stage and determines the behaviour of employees. Subsequently, the departments, units/teams and individual employees set their strategies, objectives and timelines.

Setting clear objectives would guide employees to steer their efforts toward a particular target (Aguinis, 2019). Setting targets is very crucial in performance management. A target is a goal, standard or result to be achieved within a particular period (Asare-Bediako, 2013). The targets that are set for employees should be aligned with the hotels' objectives and should be specific, measurable, achievable, realistic and timely (SMART), and challenging enough to help guide improvement in employee performance on the job. During the execution of targets, managers meet with their subordinates regularly to communicate work-related issues and give appropriate and relevant feedback.

The key performance measures involve the decision of measurements to be selected and should align with operations, targets, and whatever needs to be measured. According to Ferreira and Otley (2009), elements that determine performance measures include the management structure of the hotel, its competitors and policies. The performance measurement to be chosen should be concise to maintain its effectiveness. Examples of performance measurements are employee productivity in terms of satisfying customers (since hotels belong to the service sector), rate of absenteeism, readiness of hotel rooms on time during lodging and departure, rapid request response to guests, promptness of picking guests who may not be able to find their way to the hotel and lost in town.

According to Ferreira and Otley (2009), performance review forms an integral part of management control and should be conducted at every level of the hotel, from departments, units, and teams right down to individual employees. Performance review is done annually or bi-annually between managers and their subordinates. Ideally, the review should be objective to either help in decision-making or employee development.

Rewards systems are meant to serve as incentives for employee performance and motivation. The reward could be intrinsic (internal) or extrinsic (external). It could be in the form of financial or non-financial rewards. Examples are recognition, promotion, bonuses, salary increment, team-based incentives like profit sharing and goal-based rewards. A conducive work environment could also improve employee productivity.

Hans-Peter (2014) recommended that before an organisation decides to establish a performance management system, there should be HRM practices to support the entire process. PMS must be aligned with the HR system for it to succeed. This is because, for instance, the values of the organisation underpinning PMS should be identical to those used for HR functions such as recruitment, staffing, training and development. Patel et al. (2020) reiterated that to integrate the fundamental components of PMS into HR subsystems, HR Specialists play a critical role in ensuring their effectiveness and success. They further mentioned some of the HR functions connected to PMS as performance appraisal, reward and compensation, training and development, succession planning and employee retention.

Aguinis (2019) suggested that local context is necessary when designing PMS. In designing a performance management system, the national and organisational cultures of the country should be considered. Particularly in the service industry like hotels. Singh (2019) indicates that the achievements of employees and an organisation as a whole rely heavily on organisational culture. Studies have also confirmed that national culture has an enormous impact on corporate culture in many aspects. Some areas of influence include human resource management practices, decision-making, management techniques, communication, organisational strategy, motivation etc. (Szydło & Grześ-Bukłaho, 2020; Owusu Ansah and Louw, 2019; Khan & Law, 2018). Abane and Phinaitrup (2020) reiterated that the success of PMS would depend on how effectively contextual factors such as top management support, organisational capability, and national and organisational culture would be planned and implemented in the PMS process.

Although literature has considered the six dimensions of national culture (Hofstede, 2011) - Power Distance, Uncertainty Avoidance, Individualism/Collectivism, Masculinity/Femininity, Long/Short Term Orientation and Indulgence/Restraint, given the cultural differences in

Ghana, the national culture of Politeness and Hospitality has not been considered in the hotel subsector. This study would contribute to the literature by considering the implementation of PMS in the Ghanaian cultural context of Hospitality and Politeness.

Further, many corporate culture dimensions have been considered in the literature (Hardiyanti et al., 2022; Akinlabi et al.,2021; Wang et al., 2021 & Sawalha et al., 2012). They include Interpersonal Relationships, Empowerment, Competence Development, Fair Rewards, Information Sharing, Trust, Competent, Harmonious, Loyal, Adaptive, Collaborative, Creation, Adhocracy, Clan, Market, and Hierarchy cultures. However, the last four dimensions are well-known across the globe. Although the culture of **Hierarchy** has been extensively studied, it has not been measured under human resource management in the hotel industry in Ghana. In addition to the **national culture of Politeness and Hospitality**, this study seeks to contribute to performance management literature by looking at how the Ghanaian **corporate culture of Hierarchy and Respect for the individual, supportive and experience** would assist in its effective implementation in the hotel industry.

Productivity and employee engagement directly influence the performance of an organisation. They both go together – when the latter is addressed, the former is superintended. Employees who are well engaged impact their attitude, behaviour, commitment and ability. They are motivated to get results leading to the optimisation of productivity (PossibleWorks, 2023). Moletsane et al. (2021) in their study to investigate whether the sugar industry in South Africa was ruined by low productivity and employee engagement, found among others that there is a significant relationship between employee productivity and employee engagement. They suggested that to enhance productivity, employee engagement should be improved through job satisfaction and dignity in the organisation. PossibleWorks (2023) again argued that employee recognition process, rewards, building a better corporate culture, setting clear goals for managers and employees as well as creating transparent channels of communication enhance employee engagement and productivity. Teamwork, Managers and subordinates' relationship, Job satisfaction, Motivation and Training and Development are used as specific factors under the dependent variables.

Figure 1. Model Conceptual Framework showing how performance management system influenced by both national and organisational culture can lead to its successful implementation in the hotel industry in Ghana.

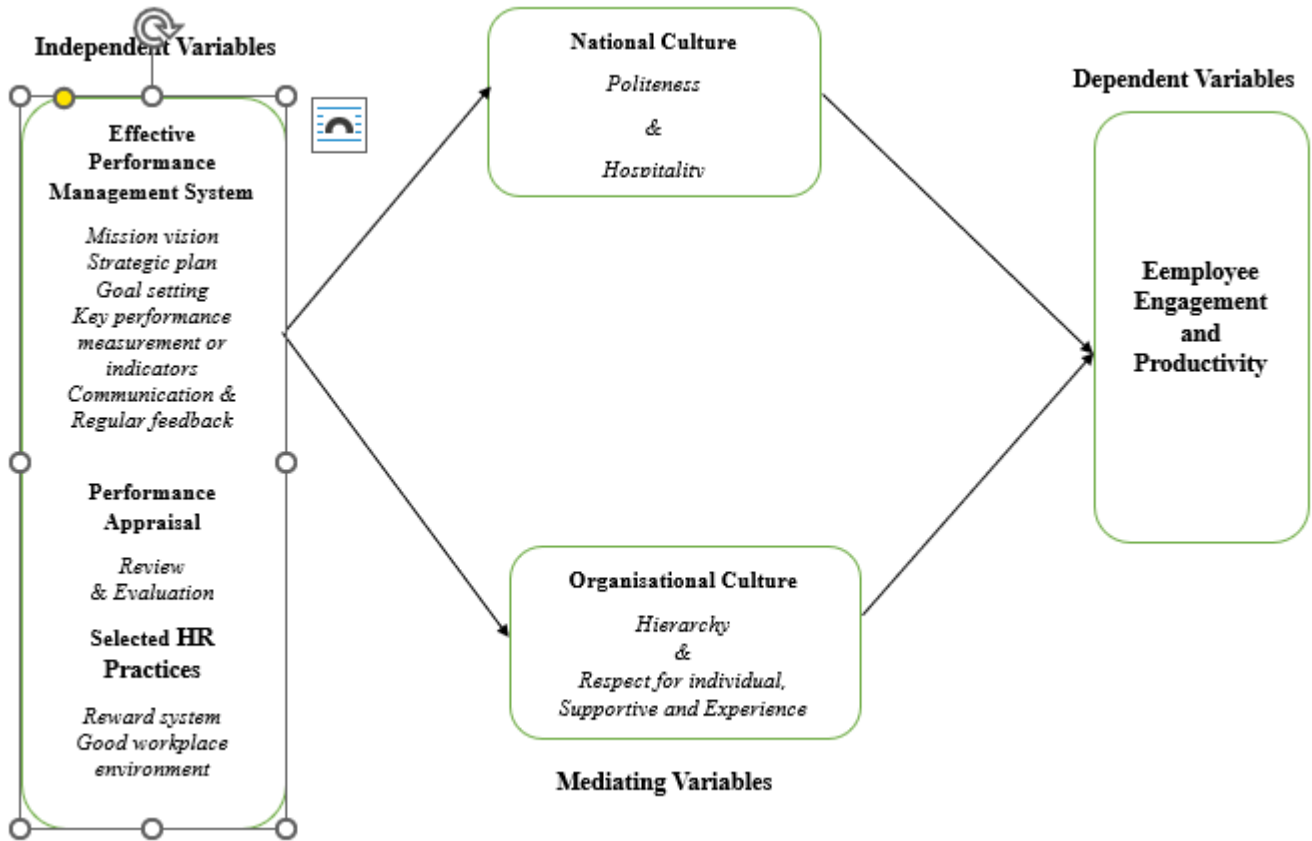

Source: Field Data, (2022)

2. MATERIAL AND METHODS

2.1 Overview of Study Area

Accra is the capital and the largest city in Ghana with an area covering 225.67 square kilometers and a population size of 2,605,40. It is the most urbanised and has experienced fast growth since the 1990s with chains of hotels, (both national and international), restaurants and other huge buildings (World Population Review, 2022). Accra is also the administrative seat of government as well as the economic and educational center of Ghana. The Greater Accra Region has the largest number of licensed hotels (about 813 in 2018 but reduced to about 650 in 2020 due to the impact of COVID-19). According to Sasu (2022), most of the leading hotels could be found in the Greater Accra and Central regions of Ghana as of the year 2022, particularly, hotels with rooms available for use by guests.

2.2 Research Design

The study used mixed-method designs. For the quantitative, a Cross-sectional survey was chosen for this study because of its function. Cross-sectional survey designs comprise gathering data at a point in time that serves the purpose (Sullivan & Calderwood, 2016).

Measurement models confirmatory factor analysis (CFA), as well as structural equation models (SEM) were adopted. The CFA approach was used to test the measurement models that formed the basics of a full structural equation model (SEM).

Appropriate fit indices such as the Goodness-of-fit index (GFI), Adjusted goodness-of-fit index (AGFI), Comparative fit index (CFI), Tucker-Lewis index (TLI), Normed-fit index (NFI), Root mean square error of approximation (RMSEA) were used to check the fitness model. Reliability and Validity Tests were conducted for the Confirmatory Factor Analysis Models (attached at the end).

In addition to the cross-sectional survey, the researcher employed a phenomenological approach (descriptive philosophy) in posing interview questions to the human resource departments of selected hotels that already practice PMS to identify the process of implementation, challenges, solutions deployed, recommendations and if the hotels' opinion about scaling up PMS to other hotels in Ghana.

2.3 Data Collection Tools and Source, Population of the Study, Sample Size and Technique

Sources of information for this research were based on both secondary information and primary data sources. Both were sourced from hotels in the Greater Accra Region using a questionnaire and semi-structured interview questions.

Ghauri and Gronhaug (2002) state that secondary data is information collated for objectives that may be different from the researcher's aim. This study relied on secondary sources to discover scholarly findings, statements, and opinions published in articles, hospitality management and HR reports, journals, books, magazines, and newspapers connected to the subject and available online and in libraries to enhance the validity and reliability of the study.

According to Ghana Tourism Authority Regional Administration, Accra, as of 2018, licensed formal accommodation establishments in Accra, categorised into guest houses, lodges, budget and star-rated hotels totalled 813. However, from the same source, this figure was reduced to about 650 with an approximate total population of 2880 as of 2020, due to the negative effects of the COVID-19 pandemic. Some budget hotels remained closed even after the lockdown. During the data collection, the researcher identified some hotels that were still not functional. Based on these statistics, the study population is 2880 hotel employees in the Greater Accra Region of Ghana.

For the quantitative approach, out of the 650 estimated number of hotels, the study covered 255. Taro Yamane's formula was employed to arrive at the sample size using the target population of 2880. According to Chaokromthong & Sintao (2021), Taro Yamane's method of calculating sample size is suitable for survey research and a definitive population.

The sample size is worked as follows:

Population size: Approximately 2880

Error margin: 0.03 (97% confidence level)

$$\text{Sample Size} = \frac{N}{1+N \cdot e^2}$$

N= Population Size

e = error margin

$$= \frac{2880}{1+(2880 \cdot 0.03^2)} = 801.78 \text{ (approximately 800)}$$

Based on this statistics, the study sample size was approximately eight hundred (800), which is about 28% of the total population of the hotels. Hence, the total number of questionnaires distributed stood at 800. As indicated by Ahmad and Halim (2017) choosing a sample size for a study demands compromises between appropriateness, statistical significance and prudence.

Out of the 800 distributed questionnaires, about 700 (87.5%) of the sample size were retrieved and used for the analysis. The reason is that most of the hotels are recovering from the devastating effects of the COVID-19 pandemic and therefore their focus was more on marketing their hotels. Several visits met some of the respondents absent, hence, the shortage. This sample size was representative enough to give a true reflection of the subject under study.

For the qualitative approach, 26 managers and other senior officers from the human resource management department of some selected star-rated hotels use PMS. They were selected using purposeful non-probability sampling. Purposive sampling was the most effective method for selecting the 26 participants since it allowed the researcher to choose those who were familiar with the PMS practiced in their hotels and had the requisite work experience and motivation to provide enough data to participate in the interview. Moreover, the chosen technique is simple to implement, cost-effective and more convenient.

2.4 Analysis of Data

The data collected were analysed with SPSS version 26, including Amos 25 version. A maximum likelihood-based confirmatory factor analysis (CFA) approach was used to test the measurement models underlying a full structural equation model (SEM) (see e.g., Lohmöller, 1989; Kline, 2015; Hair, Sarstedt, Ringle, & Gudergan, 2018). Appropriate fit indices such as the Goodness-of-fit index (GFI) (see Jöreskog & Sörbom, 1986), Adjusted goodness-of-fit index (AGFI) (see Mulaik et al., 1989), Comparative fit index (CFI), Tucker-Lewis index (TLI) (see Byrne, 2001), Normed-fit index (NFI) (see Byrne, 2001), Root mean square error of approximation (RMSEA) (see Brown, 2006) were used to check the fitness model. Reliability and Validity Tests were conducted for the Confirmatory Factor Analysis Models (Shin, 2005; DeVellis, 2012; Kline, 2015; Hair et al., 2018, among others).

The CFA approach was used to test the selected independent latent variables namely performance management system (PerfMS), performance appraisal system (PerAppraisal), and selected human

resources practices (HRPract). The measurement items were weighed on a 5-point Likert scale from 1 (strongly disagreed) to 5 (strongly agreed). The measurement items under PerfMS include “Wrong design of performance management system,” “Failing to integrate performance management system in HR, strategic plan and culture of the hotel,” “Involving managers, supervisors and officers in the development of the system,” “Lack of training before the start of implementation. A 5-point Likert scale was chosen because it takes less time to fill out and it is easy for respondents to understand. These variables were taken from the questionnaire.

The dimensions used to measure national culture (NC21) include “Management and employees accept each other and work together irrespective of their status to enhance performance”, “Employees greet each other, make friends easily and shake hands when they meet. This promotes teamwork and goal achievement”, and “Employees acquaint themselves with guests and make them feel at home all the time, promoting business to meet hotel goals”.

For organisational culture (OC22), the following were used as measurement “Supervisors find it difficult to give feedback to their subordinates especially, negative feedback because it is regarded as disrespectful”, “Supervisors support their subordinates in the area of duty”, “Employees respect older colleagues irrespective of position”.

Further, the dependent variables Employee Engagement and Productivity (EEPROD) were measured by “Highlight performers (for example, projecting the best performer for the month).” “Performance is linked to bonuses”, “Fair performance appraisal system”, “Delighting employees with the unexpected/surprises.

Hypotheses were tested using confirmatory analysis and structural equation models using AMOS 25 version to determine the positive and significant relationship among the selected variables, as well as if organisational and national cultures mediate the variables. The results of the analysis were presented using tables and diagrams.

The qualitative data obtained from the interview were transcribed into text and analysed through the lenses of the research objectives and questions.

3. RESULTS AND DISCUSSION

3.1 Quantitative Analysis

The sections are presented as follows: First, the demographics of respondents, the measurement model, confirmatory analysis, the full models, the structural equation models and a discussion of the findings. They are presented based on the study objectives.

3.1.1 Demographic and Background Characteristics of Respondents

Table 1 represents the demographic and background characteristics of respondents. Information in the table regarding the gender of respondents shows that males were 371, representing 53.2%, and females 329 representing 46.8%. The inference is that the majority of the voices had a masculine effect. Concerning age, 387, representing 50.9%, were between 21-30 years and 150 representing 29.2% were between 31- 40 years. Respondents that fell with the age of 41-50 were in a minority, 12.9% and the least were respondents aged above 50, 7 (4.7%). The results indicate that most of the respondents who partook in this study were of their youthful age. These representations could emphasise the study, given that the findings displayed the thoughts and beliefs of various groups of respondents, as shown in Table 1. The educational qualifications of respondents in the study were diverse, spanning from high school education to advanced degrees. A comprehensive overview of education attained by the respondents is presented in Table 1. From the table, only one person had a third degree representing 0.13% of the respondents. This is followed by 9 (1.29%) second degree holders. The largest group of respondents had a first degree 267 (38.14%). They were closely followed by respondents with HND, 219 (31.29%) of the entire respondents. A significant portion of the respondents, 188 (26.86%), had obtained a vocational/technical certificate. Just as importantly is a small fraction of the respondents, 16 (2.29%), who had completed the West African Senior School Certificate Examination (WASSCE) level. The levels of education of respondents suggest a large proportion had the requisite practical skills-based education and knowledge in their respective fields and could provide the required information for the study. Concerning the positions of the respondents in their respective hotels, the majority were officers representing 311 (44.4%). This was followed by departmental/unit heads representing 246 (35.1%) and general managers being 135 (19.3%). Owners of hotels formed the minority with 8 (1.2%). Table 1 indicates that most of the respondents of the study have acquired higher education and occupied responsible positions. This suggests that the population under deliberation was well informed to give appropriate and up-to-date information. According to the table, 135 (19.3%) of the respondents have been working with the hotel for less than one year. 275 (39.2%) of respondents

have worked in the hotel business between 1-5 years. 139 (19.9%) of the respondents have worked in the hotel industry for between 6-10 years. 151 (21.6%) of the respondents have worked for more than 11 years. It can be seen that the majority of the respondents have been in the hotel industry for one year and beyond. Presumably, employees who have spent more than a year in a hotel are deemed to have a good understanding of its human resource management issues. Implying that they may have ample knowledge of performance management-related issues.

Table 3. Demographic and Background Characteristics of Respondents

	Variable	Frequency	Percent
Gender	Male	371	53.2
	Female	329	46.8
	Total	700	100
Age Group	Under 20	34	2.3
	21-30 yrs	387	50.9
	31-40 yrs	150	29.2
	41-50 yrs	122	12.9
	+ 50 yrs	7	4.7
	Total	700	100
Educational Qualification	Third degree	1	0.13
	Second degree	9	1.29
	First degree	267	38.14
	HND	219	31.29
	Vocational/Technical Certificate	188	26.86
	WASSCE	16	2.29
	Total	700	100
Years of Service	Less than 1 year	135	19.3
	1-5 yrs	275	39.2
	6-10 yrs	139	19.9
	11 years and above	151	21.6
	Total	700	100
Position Occupied	Hotel Owner	8	1.2
	Departmental /Unit Heads	246	35.1
	Officers	311	44.4
	General Managers	135	19.3
	Total	700	100

Source: Field Data, (2022)

3.1.2 Categories of Hotels Studied

The study covered 255 hotels. Out of which 7.06% were foreign and 92.94% local hotels. More than 50 percent (50.59%) were budget hotels. Followed by 3-star hotels (20.39%), 2-star hotels (14.12%), 4-star hotels (5.88), 1-star hotels (3.92%), 5-star hotels (2.75%), 3.5-star hotels (1.96%) and the least were 2.5-star hotels (0.39%).

3.2 Measurement Models-Confirmatory Factor Analysis

Two measurement models were constructed using confirmatory factor analysis (CFA). Specifically, the parameters were estimated using the covariance-based (CB) approach under the structural equation modeling (SEM) framework. In the first measurement model, a CFA was performed for the independent latent variables namely performance management systems (PerfMS), performance appraisal system (PerAppraisal), and selected human resources practices (HRPract). The CFA model is presented in Figure 1, while the unstandardised and standard parameter estimates are captured in Table 2.

The results from Figure 2 and Table 2 show that all the measures of the latent variables in the measurement models are significant. Further, the fit statistics are presented in Table 4, while reliability and validity tests of the constructs are offered in Table 5.

Figure 2. shows the confirmatory factor analysis of Performance management system, Performance Appraisal and Selected Human Resources Practices. In Figures 3 and Table 3, what is the basis for deciding for the confirmatory analysis? Is there any cutoff point to admit each of the variables as a factor of PMS, HR Pract and Per Appraisal?

Figure 2. Confirmatory factor analysis of Performance management system, Performance Appraisal and Selected Human Resources Practices (Independent Variables)

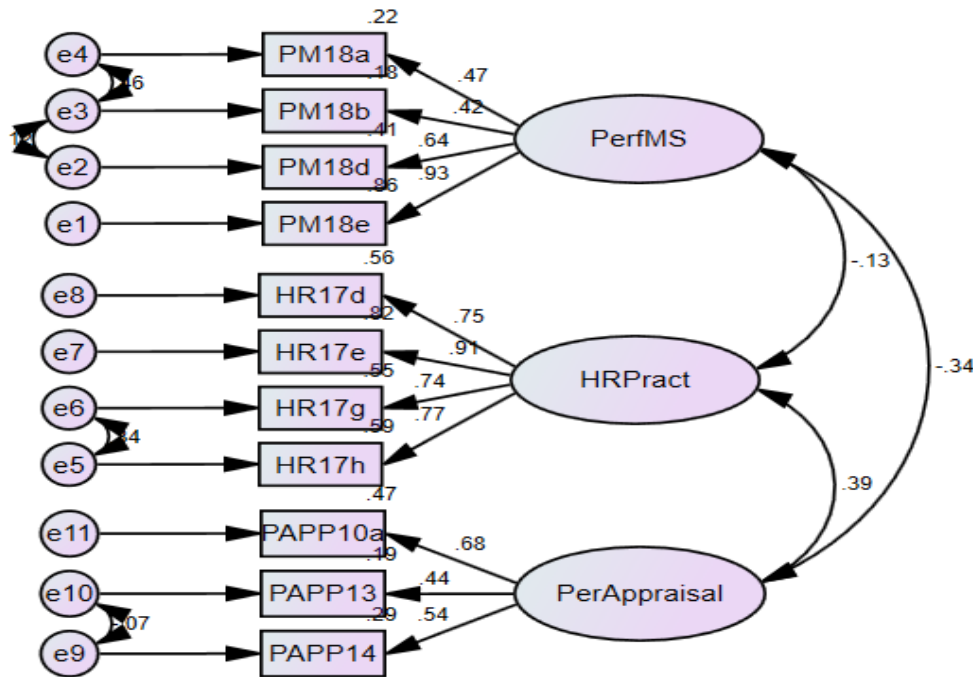

Source: Author’s own construct, 2022

Table 2. Standardised and unstandardised estimates of CFA for PMS, Performance Appraisal, Selected HR Practices and employee engagement and productivity.

Measures	Direction	Construct	Unstandardised Estimate	Standardised Estimate	S.E.	C.R.	P
PM18e	←	PerfMS	1.000	0.928			
PM18d	←	PerfMS	0.679	0.644	0.061	11.193	***
PM18b	←	PerfMS	0.391	0.419	0.045	8.718	***
PM18a	←	PerfMS	0.433	0.474	0.045	9.680	***
HR17h	←	HRPract	1.000	0.770			
HR17g	←	HRPract	0.938	0.742	0.038	24.487	***
HR17e	←	HRPract	1.107	0.907	0.051	21.896	***
HR17d	←	HRPract	0.925	0.745	0.047	19.744	***
PAPP14	←	PerAppraisal	1.000	0.538			
PAPP13	←	PerAppraisal	0.875	0.440	0.120	7.267	***
PAPP10a	←	PerAppraisal	2.106	0.684	0.300	7.029	***

Notes: S.E, C.R., and P are the standard errors, critical ratio (estimate/S. E), and p-value, respectively.

Source: Field Data, 2022

Similarly, the second measurement model using CFA is presented below: The CFA model diagram and the parameter estimates are presented in Figure 2 and Table 3, respectively.

Figure 3: Confirmatory factor analysis of national and organisational cultures, and employee engagement and productivity.

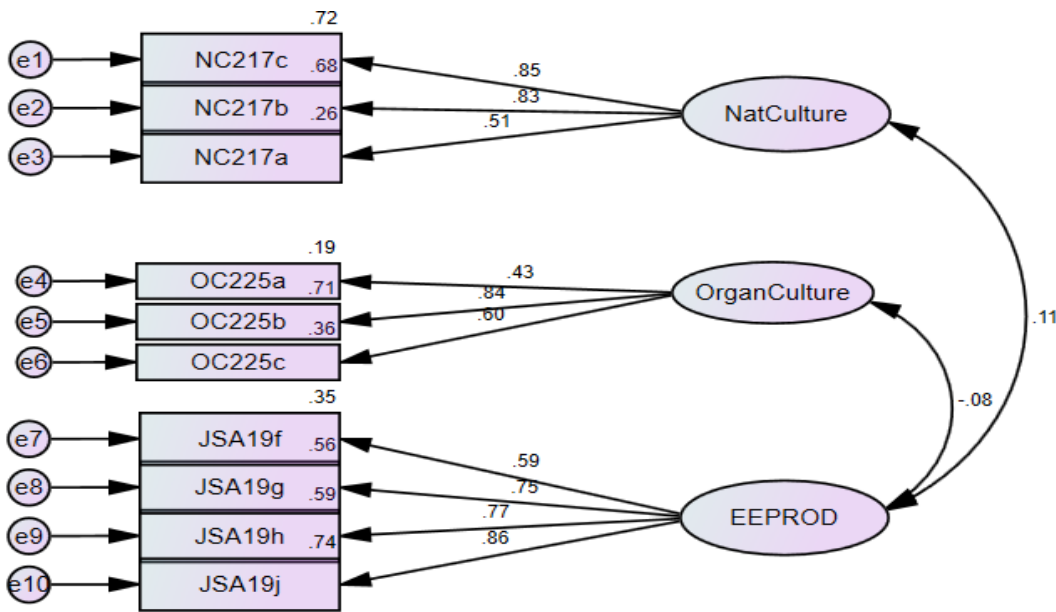

Source: Author’s own construct, 2022

Table 3. Standardised and unstandardised estimates of CFA for organisational, national cultures and Employee engagement and productivity.

<i>Measure</i>	<i>Direction</i>	<i>Constructs</i>	<i>Unstandardised Estimate</i>	<i>Standardised Estimate</i>	<i>S.E.</i>	<i>C.R.</i>	<i>P</i>
NC217a	←	NatCulture	1.000	0.505			
NC217b	←	NatCulture	1.573	0.826	0.129	12.212	***
NC217c	←	NatCulture	1.557	0.848	0.129	12.039	***
OC225c	←	OrganCulture	1.000	0.598			
OC225b	←	OrganCulture	1.388	0.841	0.177	7.827	***
OC225a	←	OrganCulture	0.789	0.435	0.087	9.019	***
JSA19h	←	EEPROD	1.000	0.767			
JSA19g	←	EEPROD	1.061	0.748	0.056	19.082	***
JSA19f	←	EEPROD	0.853	0.591	0.057	14.919	***
JSA19j	←	EEPROD	0.759	0.861	0.036	20.851	***

Source: Field Data, 2022

Fit indices of the hypothesised models and the data

Table 4 shows the results of the degree of relationship/relatedness between the selected variables in the hypothesised models. All the fit statistics are within acceptable levels as shown in the notes of Table 4. Therefore, it can be concluded that the items loaded on the constructs are good measures of the independent constructs.

Table 4: Fit indices of the hypothesised models and the data

Model	χ^2	df	p	χ^2/df	GFI	AGFI	NFI	TLI	CFI	RMSEA
SEM Model1	410.542	119	0.000	3.500	0.909	0.940	0.922	0.908	0.942	0.048
SEM Model2	428.274	123	0.000	3.482	0.919	0.908	0.977	0.969	0.905	0.044

Notes: Goodness-of-fit index (GFI) (> 0.90), Adjusted goodness-of-fit index (AGFI) (> 0.9), Comparative fit index (CFI) (> 0.90), Tucker-Lewis index (TLI) (> 0.90), Normed-fit index (NFI), Root mean square error of approximation (RMSEA) (< 0.05). All the fit statics are within acceptable levels. χ^2/df is also within the acceptable range (≤ 3.50).

Source: Field Data, 2022

3.3 Reliability and Validity Tests for the Confirmatory Factor Analysis Models

Tables 5a and 5b show the reliability and validity tests performed of the CFA and structural equation models on the latent variables as well as culture, employee engagement and productivity. The values in the tables represent the coefficients of reliability and validity among the latent variables showing their relationships.

Table 5a: Reliability and Validity Tests for the Confirmatory Factor Analysis Models

Panel A: Confirmatory Factor Analysis of Independent variables					
	CR	AVE	DV		
Latent Variable			PerfMS	HRPract	PerAppraisal
PerfMS	0.723	0.519	0.720		
HRPract	0.871	0.630	-0.132	0.794	
PerAppraisal	0.774	0.517	-0.342	0.386	0.719
Panel B: Confirmatory Factor Analysis of Culture and Employee Engagement and Productivity					
	CR	AVE			
Latent			OrganCulture	NatCulture	EEPROD

Variable					
OrganCulture	0.768	0.518	0.647		DV
NatCulture	0.779	0.552		0.743	
EEPROD	0.833	0.560	-0.083	0.110	0.748

Notes: CR, AVE, DV are the measures of composite reliability, converge validity and discriminate validity.

Table 5b: Reliability and Validity Tests for the Structural Equation Models

Panel A: Structural Equation Model with Organisation Culture					
	CR	AVE	DV		
Latent variable			PerfMS	HRPract	PerAppraisal
PerfMS	0.856	0.699	0.836		
HRPract	0.761	0.520	-0.104	0.721	
PerAppraisal	0.708	0.535	-0.129	0.256	0.731

Panel B: Structural Equation Model with National Culture					
	CR	AVE	DV		
Latent variable			PerfMS	HRPract	PerAppraisal
PerfMS	0.705	0.526	0.726		
HRPract	0.785	0.545	-0.103	0.738	
PerAppraisal	0.742	0.530	-0.380	0.536	0.728

Composite reliability, converge validity and discriminate validity tests.

Following literature (-----), composite reliability (CR) > 0.7, convergent validity (AVE) > 0.5, and discriminant validity (DV) > the ins are more appropriate. Hence, the measures of the latent constructs are reliable and valid according to the CFA.

3.4 Structural Equation Model

The following hypotheses were tested for (i) Total effects models and (ii) mediation models, and the results are presented below:

Research Hypotheses

Total Effects Models for Organisational Culture

The total and direct effects for the three constructs (H1, H2 and H3) using organisational culture as the mediating variable are presented in Table 6a and Table 6b respectively.

According to Table 6a, in examining the effect of organisational culture on the relationship between the three independent variables on Employee Engagement and Productivity, it was found that the total effect was not statistically significant ($\beta=-0.019$, $p=0.124$) of the relationship between effective Performance Management System and Employee Engagement and Productivity. Hence, the hypothesis is not supported. Furthermore, there was no significant total effect of the relationship between the Performance Appraisal system and Employee Engagement and Productivity ($\beta=-0.011$, $p=0.125$).

The Selected HR has a positive and significant relationship with Employee Engagement and Productivity. In the case of the relationship between Selected HR and Employee Engagement and Productivity, the total effect was not supported ($\beta=-0.042$, $p=0.086$).

The results in Table 6b, Effective Performance Management System had no direct effect on Employee Engagement and Productivity ($\beta=-0.016$, $p=0.678$). The analysis also revealed that the Performance Appraisal system had no direct significant effect on Employee Engagement and Productivity ($\beta=0.009$, $p=0.067$). Moreover, the Selected HR did not show any direct effect on Employee Engagement and Productivity ($\beta=-0.032$, $p=0.245$).

The main outcome for H1, H2 and H3 is that organisational culture positively and insignificantly impacts employee engagement and employee productivity. In total, they were not supported by the data.

This does not agree with Sopiah et al. (2020) who in their study investigated the relationship between work engagement and talent management and its influence on nurses' performance in Indonesia and found a positive effect between talent management, work engagement and employee performance. Awan et al., (2020) also found a significant influence between employee performance, work engagement and performance management system effectiveness in their study to identify the effectualness of PMS in the banking industry in Pakistan using a sample size of 285 employees selected from various branches of private banks located across Pakistan.

The results of organisational culture having a direct impact on employee engagement and productivity, and a weak direct relationship that may exist are not supported by the output of the empirical analysis. Although organisational culture has a positive influence on employee engagement and employee productivity, the impact has not reached significant levels. Organisational culture is a major factor in performance management system. The results could mean that the hotels' organisational cultures were not well communicated to the employees. It could also be that most of the international hotels' 'import' the organisational culture of the headquarters to the country which may not sit well with the Ghanaian employees, or the Ghanaian employees may not understand the foreign cultures unless the necessary training is carried out. Hotels should communicate the culture effectively and properly to the local employees. Foreign organisational culture should be customised to suit the local context. In addition, hotels should ensure that their culture aligns with the goals and objectives of the performance management system and encourage a culture of continuous learning and development. This can impact positively on employee engagement and productivity. A culture that prioritises employee development and growth may lead to a more positive perception of the PMS, as employees would see the value in the feedback and development opportunities provided through the system (Nkomo, 2014). Additionally, a culture that values open communication and collaboration can facilitate the effective implementation of the PMS, as employees are more likely to provide honest and constructive feedback (Cameron & Quinn, 2011).

The results imply that PMS is not popular in the hotel industry in Ghana, and even the star-rated hotels that practice it may have some challenges. Organisations should therefore strive to create a culture that aligns employees' goals and objectives with that of the organisation and promote employee development and growth. This would in turn ensure an increase in employee engagement and productivity. Additionally, organisations should encourage open communication and collaboration to facilitate the effective implementation of the PMS.

The results also suggest that the selected organisational cultures of respect for individual, supportive, experience and hierarchy would contribute to employee engagement and productivity when added to the design and implementation of PMS. That is, if hotels' management take the necessary steps to enforce them.

Table 6a: Total Effects Models for Organisational Culture

DV	Direction	IV	<i>Unstandardised Estimate</i>	<i>Standardised Estimate</i>	SE	P-value	Sig
EEPROD	←	PerAppraisal	-0.015	-0.011	0.010	0.125	No
EEPROD	←	HRPract	-0.021*	-0.042	0.013	0.086	No
EEPROD	←	PerfMS	-0.003	-0.019	0.002	0.124	No
EEPROD	←	OrganCulture	0.052**	0.096	0.021	0.047	Yes

Notes: ***/*** significant at 5%/1%, respectively. The parameters are estimated using bootstrap (1000 resamples) using 95% bias-corrected confidence level. DV and IV denote dependent and independent variables.

Source: Field Data, 2022

Table 6b: Direct effects model for Organisational Culture

DV	Direction	IV	<i>Unstandardised Estimate</i>	<i>Standardised Estimate</i>	S.E	P-value	Significance
EEPROD	←	PerAppraisal	0.012	0.009	0.006	0.067	Yes
EEPROD	←	HRPract	-0.016	-0.032	0.013	0.245	No
EEPROD	←	PerfMS	-0.003	-0.016	0.003	0.678	No

Notes: ***/*** significant at 5%/1%, respectively. The parameters are estimated using bootstrap (1000 resamples) using 95% bias-corrected confidence level. DV and IV denote dependent and independent variables.

Total Effects Model for National Culture

The total and direct effects for the three constructs (H4, H5 and H6) using national culture as the mediating variable are presented in Table 7a and Table 7b correspondingly.

Table 7a shows the total effects model on national culture on the three constructs. The main outcome is that national culture positively and significantly impacts employee engagement and productivity.

The result obtained suggests that the total effect was not statistically significant ($\beta=0.006$, $p=0.067$) of the relationship between effective Performance Management System and Employee Engagement and Productivity. Hence, the hypothesis is not supported. Additionally, there was a significant effect on the total effect of the relationship between Performance Appraisal system and Employee Engagement and Productivity ($\beta=0.110$, $p=0.042$). Hence, the hypothesis is supported.

Selected HR also has a positive and significant relationship with Employee Engagement and Productivity ($\beta=0.062$, $p=0.014$). Hence, the hypothesis is supported.

Table 7b indicates the direct effects that national culture has on the three constructs.

The results specify that there was no direct effect between Effective Performance Management System and Employee Engagement and Productivity ($\beta=0.007$, $p=0.450$). Hence, the hypothesis is not supported. Table 7b however, suggests that there was a direct effect between the Performance Appraisal System and Employee Engagement and Productivity ($\beta=0.142$, $p=0.015$). This hypothesis is therefore supported. The results again showed a positive and significant direct effect between Selected HR and Employee Engagement and Productivity ($\beta=0.032$, $p=0.043$). Hence, the hypothesis is supported.

The main outcome is that national culture positively and significantly impacts employee engagement and productivity.

Table 7a shows the total effects model for the national culture. Performance Appraisal, HR Practices with the influence of national cultures have a positive and significant effect on employee engagement and productivity. Meaning that H5 and H6 support and have a direct effect on the dependent variable. On the other hand, (4) Performance Management System has a positive relationship with employee engagement and productivity. However, it has no significant influence on employee engagement and productivity. This could be a result of the challenges faced in the implementation of PMS such as lack of employee engagement in the design of the system, lack of management support, not setting specific, measurable, achievable, realistic and time-bound goals etc. Like the total Effects on organisational culture, measures that would improve the implementation of PMS such as effective communication, giving regular feedback, and coaching should be considered when designing PMS to ensure its effectiveness.

The outcome of the hypotheses tested shows that majority of the hotels in Ghana do not practice a performance management system. This is a gap this study seeks to close. PMS when effectively designed and implemented would improve employee engagement and productivity. Furthermore, for PMS to influence employee engagement and productivity, the hotels must ensure that employees are involved in the design and implementation of PMS, regular feedback is key and the entire process must be aligned with the organisational goals. Again, although performance management system has a positive relationship with employee engagement and productivity it has no significant influence because majority of the hotels were not practicing PMS and the ones that had already implemented the system in their hotels were faced with certain challenges.

This was proved by Ohemeng (2018) who indicated that the implementation of PMS failed in the public sector in developing countries because of employees' negative perception of the system and management not taking the necessary steps to rectify the misconception surrounding it.

The results are in line with Hassan et al. (2022) when they mentioned that performance appraisals are tools that aid human resource management and are well recognised by employees, and Saks (2022) who said that good HR practices improve employee engagement, impacting positively on their job performance for the good of the organisation. It also affirms Hans-Peter (2014) recommendation that before an organisation decides to establish a performance management system, there should be HRM practices to support the entire process. The selected national culture is consistent with Ghanaians hence, it has a positive and significant relationship with employee engagement and productivity. It, therefore, buttresses the assertion of Aguinis, (2019); Abane and Phinaitrup (2020), who argued that national culture should be incorporated into the design and implementation of PMS.

Table 7a: Total Effects Model for National Culture

DV	Direction	IV	<i>Unstandardised Estimate</i>	<i>Standardised Estimate</i>	S.E	Significance
EEPROD	←	PerAppraisal	0.194***	0.110	0.073	Yes
EEPROD	←	HRPract	0.024**	0.062	0.010	Yes
EEPROD	←	PerfMS	0.002	0.006	0.001	No
EEPROD	←	NatCulture	0.053***	0.133	0.021	Yes

Notes: */**/** significant at 5%/1%, respectively. The parameters are estimated using bootstrap (1000 resamples) using a 95% bias-corrected confidence level. DV and IV denote dependent and independent variables.

Source: Field Data, 2022

Table 7b: Direct effect model for National Culture

DV	Direction	IV	<i>Unstandardized Estimate</i>	<i>Standardized Estimate</i>	S.E	P-Value	Sig
EEPROD	←	PerAppraisal	0.250**	0.142	0.102	0.015	Yes
EEPROD	←	HRPract	0.012**	0.032	0.005	0.043	Yes
EEPROD	←	PerfMS	0.002	0.007	0.010	0.450	No

Notes: */**/** significant at 5%/1%, respectively. The parameters are estimated using bootstrap (1000 resamples) using a 95% bias-corrected confidence level. DV and IV denote dependent and independent variables.

Source: Field Data, 2022

Mediation Model for Organisational Culture

The indirect effects for the three constructs (H7, H8 and H9) using organisational culture as the mediating variable are presented in Table 6c.

From Table 6c, the result revealed that organisational culture does not mediate the relationship between Effective Performance Management and Employee Engagement and Productivity ($\beta = -0.002$, $p = 0.287$). Hence, there is no mediation effect. Again, organisational culture mediates the relationship between Performance Appraisal and Employee Engagement and Productivity

($\beta=0.021$, $p=0.098$). Hence, there is no mediation effect. Lastly, the result suggests that Organisational Culture does not mediate the relationship between Selected HR practices and Employee Engagement and Productivity ($\beta=-0.009$, $p=0.252$). Hence, the hypothesis is not supported.

The results emphasise the weak nature of organisational culture in the hotels in the Greater Accra Region. While it remains important that organisational culture plays a vital role in the implementation of PMS, the data did not support its mediation with both independent and dependent variables. This finding reiterates the need for hotel management to communicate the hotels' beliefs, philosophies, expectations and norms to their employees. HR managers must design appropriate human resource management practices and policies that would promote the respective hotels' culture. As postulated by Lee et al. (2018) more consideration should be given to organisational culture among other things such as employee relationships and expectations which would advance employee engagement. They further advised that organisations should find ways to foster the right cultural values to improve constructive work approaches.

Table 6c: Indirect effects model for Organisational Culture

DV	Direction (OrganCulture)	IV	<i>Unstandardised Estimate</i>	<i>Standardised Estimate</i>	S.E	P- value	Sig
EEPROD	←	PerAppraisal	-0.027	-0.021	0.015	0.098	No
EEPROD	←	HRPract	-0.005	-0.009	0.004	0.252	No
EEPROD	←	PerfMS	-0.002	-0.002	0.002	0.287	No

Notes: */**/** significant at 5%/1%, respectively. The parameters are estimated using bootstrap (1000 resamples) using 95% bias-corrected confidence level. DV and IV denote dependent and independent variables.

Source: Field Data, 2022

Mediation Model for National Culture

The indirect effects for the three constructs (H10, H11 and H12) using national culture as the mediating variable are presented in Table 7c.

The result as shown in Table 7c, suggests that national culture mediates the relationship between Effective Performance Management and Employee Engagement and Productivity ($\beta=0.021$, $p=0.075$). Hence, there is a mediation effect. It is also evident that National Culture partially mediates positively between Performance Appraisal and Employee Engagement and Productivity ($\beta=0.032$, $p=0.023$). Hence, the hypothesis is supported. The results in Table 7c further suggest that National Culture partially mediates the relationship between Selected HR practices and Employee Engagement and Productivity ($\beta=0.030$, $p=0.024$). Hence, the hypothesis is supported.

Table 7c shows the Indirect effect model for National Culture. In this table, the three latent independent variables have an indirect but positive and significant effect on the dependent variable. Meaning that national culture has a role to play in performance management system. Positive national cultures such as **hospitality** and **politeness** when incorporated into the design and implementation of performance management system in the hotel industry in Ghana could ensure its effectiveness and success. This is because the Ghanaian national culture would have an indirect influence on the attitude and behaviour of the hotel employees, which may have a positive impact on their productivity. This is explained by the mediation among the variables and affirms the recommendation of researchers in this field as stated above. These results are consistent with the argument of (Aban & Phinaitrup, 2020; Aguinis, 2019).

Table 7c: Indirect effect model for National Culture

DV	Direction (NatCulture)	IV	<i>Unstandardized Estimate</i>	<i>Standardized Estimate</i>	S.E	P- value	Sig
EEPROD	←	PerAppraisal	0.056**	0.032	0.022	0.023	Yes
EEPROD	←	HRPract	0.011**	0.030	0.004	0.024	Yes
EEPROD	←	PerfMS	0.009*	0.021	0.004	0.075	Yes

Notes: ***/*** significant at 5%/1%, respectively. The parameters are estimated using bootstrap (1000 resamples) using a 95% bias-corrected confidence level. DV and IV denote dependent and independent variables.

Source: Field Data, 2022

In conclusion, the findings of this study underscore the importance of considering national and organisational cultural factors when designing and implementing PMS in the hotel industry in Greater Accra. This can help to ensure that PMS is well received and effectively used by employees, leading to improved employee engagement and productivity outcomes and increased success in the industry.

Structural Equation Model of National Culture (SEM Model 1)

The Structural Equation Model of National Culture (SEM Model 1) is presented in Figure 14.

Figure 14: Structural Equation Model of National Culture (SEM Model 1)

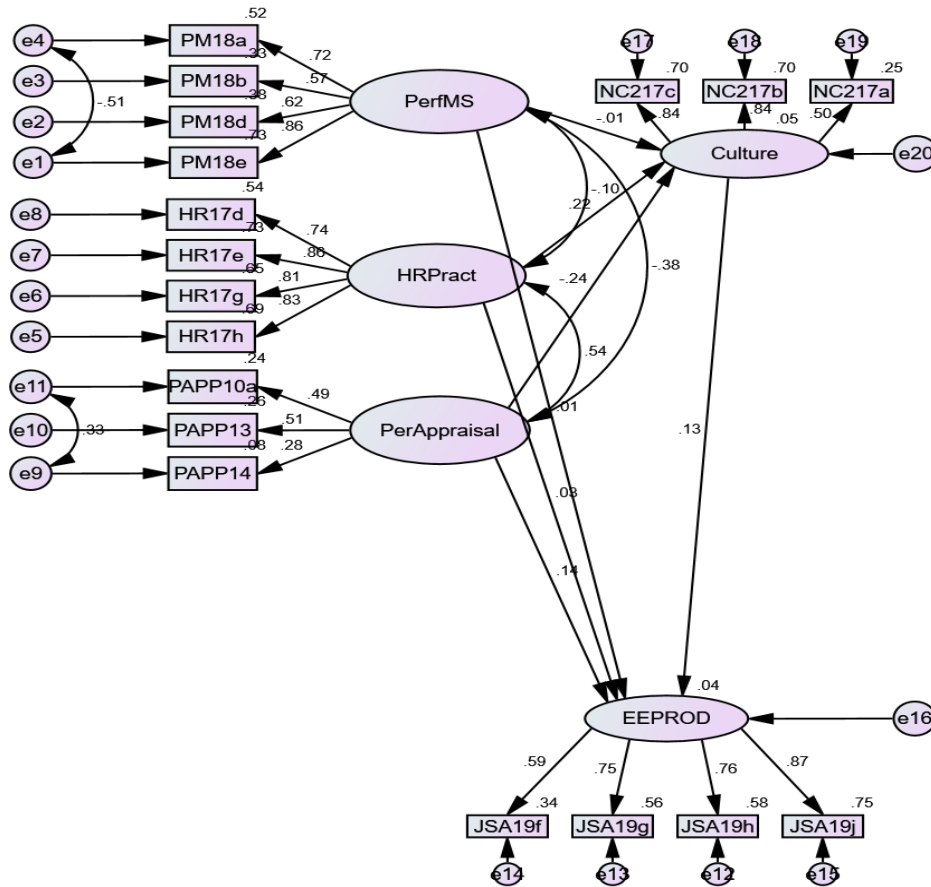

Source: Author's Own Construct, (2023)

Structural Equation Model of Organisational Culture (SEM Model 2)

The Structural Equation Model of Organisational Culture (SEM Model 2) is presented in figure 15.

Figure 3: Structural Equation Model of Organisational Culture (SEM Model 2)

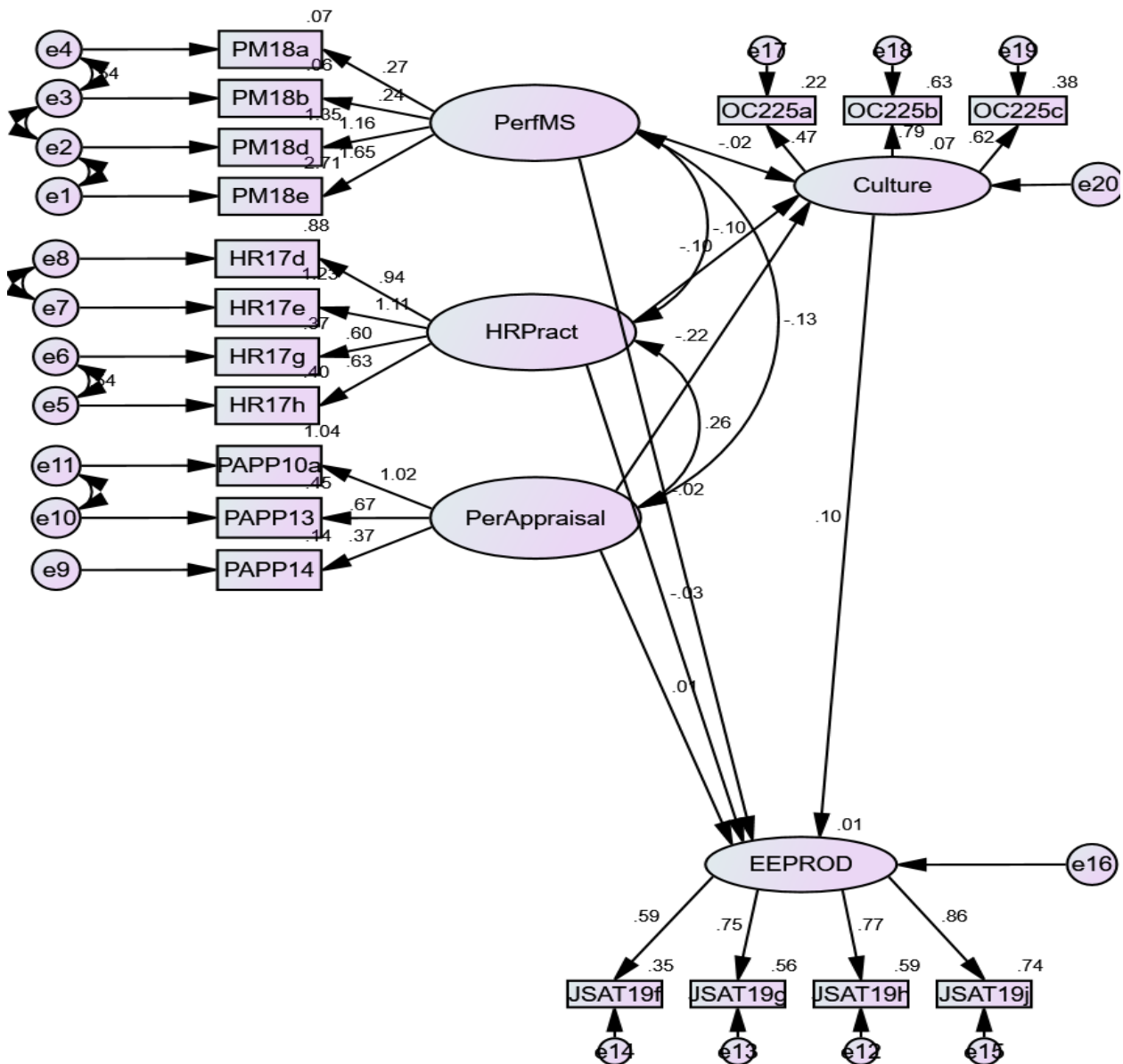

Source: Author's Own Construct, (2023)

3.5 Objective Seven - Qualitative Findings

The qualitative findings present the results of responses from participants that were selected from 26 star-rated hotels to delineate the performance management system (PMS) practised in some of the star-rated hotels in Accra.

There is no literature on PMS practised in hotels in Ghana, however, it came to light during the data collection that some of the hotels (from 2-5 stars, less than 12% of the total number of hotels) practiced PMS. Semi-structured interviews were conducted to elucidate the practice of PMS, the inception, how the process is carried out, whether the system covers all departments, challenges, solutions and recommendations. Hence, the qualitative findings cover the perspectives and realities of PMS practiced in some star-rated hotels in Accra.

These results were analysed using the descriptive philosophy. Descriptive philosophy is a naturalistic approach to collecting data, mostly through interviews and interpreting them based on the respondents' experiences and submissions about a phenomenon (Kivunja & Kuyini, 2017). It is widely used in qualitative research. Sloan & Bowe (2014) confirmed that phenomenology has two parts – descriptive and interpretive approaches. They emphasised that the interpretive approach allows for the examination of the experience or situation that helps with the interpretation and adds value to it. Heads of the human resource departments and HR officers were engaged in the interviews.

3.5.1 Demographic Representation of Research Respondents

The participants selected for the qualitative interview were within the age range of 37 – 45 years and had worked in the hotel industry for 6 years to 15 years.

3.5.2 Respondents' Perception of the Practice of PMS in Their Hotels

A question was asked whether they practiced performance management system in their hotels. All 26 respondents confirmed that they practiced performance management system. The difference is the year of implementation and the duration of practice, which varies from 5 years to 15 years.

As one participant's put it *"Yes, we practice PMS. It was already in place when I joined the hotel in 2018."* Another also said, *"It has been 15 years already since we started practicing PMS."*

In a question to find out how the process is carried out and whether the system covers all departments and units in the hotels. Almost all the respondents indicated that setting goals is done

at the departmental/unit level and the individual employee level. Tasks sheets were given to each employee and this guided performance of daily tasks. One participant puts it,

“First of all, we start by setting departmental objectives and Key Performance Indicators for all staff. Then at the end of each quarter, we evaluate them based on these objectives given. This process is repeated each quarter till the end of the year when we do the yearly one. The HR office uses the scores to review salaries and know the kind of training to plan for the staff.”

A participant from a 5-star hotel indicated that PMS is focused on immediate supervisors and their subordinates. Some mentioned that they have one-on-one meetings and monthly check-ins. Although some of these star-rated hotels had strategic plans, their target setting did not begin from the organisational level. It came to light that the results from the assessment of employees were used for training and salary increments.

Planning and goal setting happened at the department level and each employee knew their expected outcomes. Supervisors met with their subordinates and discussed progress as well as gaps. The responses indicated that performance reviews happened quarterly and climaxed with evaluation at the end of the year. PMS informs training, pay for performance and other rewards. It was also deduced from the interview that some of the hotels that practised PMS, gave their employees feedback, but was not frequent as required.

“one-on-one meetings and monthly check-ins”.

3.5.3 Challenges with the implementation of PMS and suggested solutions.

When asked about the challenges that these hotels faced in the implementation of PMS in their hotels, a participant said *“The system is detached from the hotel’s strategic plan. The system lacks incorporation and is seen as the responsibility of the HR department, with less commitment from top management.”*

Two HR managers had this to say concerning staff evaluation:

“Some staff complain of low rating”. “Others complained about biases, not really engaging staff in constructive performance appraisal meetings, but just filling out forms.”

Meaning that the system lacked maximum support from leadership and some managers were not taking performance appraisal, which is a sub-set of PMS seriously as a result of time constraints and biases.

Other challenges mentioned by the participants include some employees resisted change, time constraints causing supervisors not to give regular feedback, in some instances, feedback did not happen at all, and some supervisors lacked the skills of continuous engagement and giving an objective assessment of employees. Since the hotel industry is recovering from the impact of the COVID-19 pandemic, managers and departmental heads focused more on marketing strategies to win over old clients and attract new ones.

With regard to participants' opinions about how these challenges could be resolved, one HR manager had this to say:

"We usually organise meetings with the supervisor and subordinate concerned to resolve the issue. If after analysing the issue, we realise there is a need for re-rating, we do so."

Another participant also mentioned that:

"Encourage timely and frequent feedback. Also, managers and supervisors should be urged to conduct timely appraisals and give more detailed, constructive conversations about employee performance."

Additionally, some of the participants suggested that the hotels should provide training and support for both managers and their subordinates to understand the process involved in PMS. Implement better prioritisation and scheduling. They indicated that the hotels should also allocate resources more effectively to help with the implementation of PMS. With regards to performance appraisals that take place during the institutional year, some of the participants proposed that the hotels should introduce objective metrics and criteria, and the entire process should be standardised to reduce biases. In spite of the challenges that beset PMS, almost all the participants believed that its implementation was necessary to help departments/units and employees meet their respective targets. Respondents expressed their delight and optimism that the successful implementation and integration of PMS in hotels in Greater Accra would improve employee performance and increase productivity.

Participants were asked a follow-up question about how PMS could promote work engagement and enhance employee performance in Ghana. More than 80% of the participants posited that when individual employee goals are aligned with the organisations', regular feedback and support are provided for staff as well as encouraging employee development and growth opportunities, employees would be motivated and committed to doing their jobs and assigned roles effectively and efficiently.

As postulated by some participants,

“PMS helps the employee to have a better understanding of the departmental goals and contribute to its achievement.”

“PMS helps managers and supervisors to recognise and reward good performance encouraging employees to give their best. It also facilitates the identification of suitable performers for future higher positions.”

3.5.4 Integration of Specific National and Organisational Cultures into PMS

National Culture:

Participants were asked about their opinion of the integration of specific Ghanaian cultures like “respect for individuals” into PMS. It is important to note that the responses reflected a range of perspectives and opinions on the question. Some managers see the potential benefits of incorporating national cultural practices such as respect for individuals in the performance management system, while others were skeptical and thought it may be potentially challenging.

"Yes, I believe incorporating national cultural practices, such as respect for individuals, can greatly improve the implementation and success of our performance management system. By fostering a culture of respect and understanding of the traditional values of our employees, we can create a more positive and productive work environment."

"I think it could be beneficial in some cases, but it could also create biases and make the process more complicated. It's important to strike a balance between incorporating cultural practices and keeping the performance management system as straightforward as possible."

Integrating national cultural values into a performance management system is crucial for a number of reasons. By understanding and embracing the cultural origins and beliefs of employees, managers may create a more positive and inclusive work environment, which could increase employee engagement, motivation, and satisfaction. Understanding the cultural context of employees enables managers to communicate with them more effectively and fosters mutual respect, trust, and understanding. By matching the performance management system with the cultural values and expectations of employees, managers could build a more effective and relevant performance management system, which could improve performance and enhance productivity.

Creating a culture that is inclusive, respectful, and supportive of employees could assist managers in retaining their best employees and reducing turnover.

However, according to the participants, the Ghanaian national culture is yet to embrace the integration of PMS in hotels across board. Most of the respondents in this section were quoted saying... *“it’s not really our thing.”*

Organisational Culture:

Sure, regards to organisational culture, some of the participants affirmed that they had but were not sure, if it had been integrated into the PMS. When asked about their opinion if they should add the organisational culture of hierarchy and politeness to the PMS. About 40% of the participants were cynical because according to them, organisational culture has been a stumbling block to embracing new ideas in their hotels. The section of the participants explained that although PMS made work easier and faster, hierarchical culture, for instance, could mean top management had to approve decisions, such decisions may take a long time to make, and sometimes may not be made. Therefore, a flatter hierarchical structure may be commendable. The remaining 60% were optimistic that it would enhance their operations since they deal directly with clients and guests. A participant with such experience said:

“I would say that most of the staff are used to the traditional ways of doing things, so if organisational culture is deduced from our well-known culture, it would boost performance.”

A typical Ghanaian is always polite. Integrating the culture of politeness into the hotel industry in Ghana, would concretise respect and hospitality which already exist in the hotels.

3.5.5 Recommendation of PMS to other hotels and why

A hundred percent (100%) of the participants gave the affirmative answer when asked if they would recommend PMS to other hotels.

“Yes, because as much as it has its own challenges, it is worth the effort.”

Some argued that the implementation of PMS has improved the ability of their employees to achieve their set targets. It has also brought cohesion among departments, teams, Individuals and processes to meet goals in an efficient and effective way. One respondent is quoted saying...

“The implementation of PMS in our hotel identified, promoted, gauged, assessed, enhanced, and rewarded employee performance. The PMS has helped in controlling the workplace and the individual so that an individual or team can accomplish predetermined corporate goals.”

Organisational performance could be improved with the adoption of performance management systems. This would help the hotels gain a competitive position in the international market. Furthermore, an effective performance management system can improve employee engagement and employee productivity when hotels ‘educate’ their employees about their organisational cultural practices and inculcate relevant national culture into their human resource management practices, policies and procedures.

3.5.6 Underlying factors that influence the Relationships between PMS, Employee Engagement and Productivity

The underlying factors that could influence the relationship between PMS, employee engagement and productivity deduced from the responses include detaching PMS from the hotels’ strategic plan, lack of top management commitment, lack of regular feedback from supervisors due to time constraints, some supervisors lacked the skills of continuous engagement and giving an objective assessment of employees, biases in employee appraisals and employees resisting change.

Some of the suggestions given by more than 80% of the respondents when asked about how PMS could promote work engagement and enhance employee performance in Ghana include ‘*when individual employee goals are aligned with the organisations*’, ‘*when regular feedback and support are provided*’, ‘*encouraging employee development and growth opportunities*’, ‘*employees would be motivated and committed to doing their jobs and assigned roles effectively and efficiently*’. These would enhance the relationship between PMS, employee engagement and productivity.

Effective PMS contains a constructive employee appraisal system, good HR practices and a reward system that would motivate and induce employee commitment and engagement that would lead to high employee and organisational productivity.

These suggestions are in line with the study of Levy et al. (2017) who in their quest to find solutions to some of the challenges that beset the practice of performance management indicated that practitioners had recommended the development of a culture of feedback wherein feedback

would be given considerable importance due to its contribution to employee engagement and success of an organisation. They also proposed that some elements of accountability should be added to PMS practices. Further, PMS should be aligned with the strategic objectives of the organisation. Suherli et al. (2018) also found that the use of a balanced scorecard (a performance management strategy instrument) could improve the relationship between PMS and employee performance. Furthermore, Awan et al (2020) revealed that there is a significant influence on performance management system effectiveness and work engagement on employee performance. They proposed the introduction of an all-embracing PMS model that would increase employee engagement and performance.

The qualitative findings buttress the results in the empirical data that managers should communicate and enforce their hotel culture particularly, those in line with their strategic objectives and PMS. Further, some of the responses confirmed the need for the integration of national culture into the design and implementation of PMS to improve employee engagement and productivity as found in the quantitative analysis.

4. CONCLUSION AND RECOMMENDATION

4.1. Conclusion

From the aforementioned, it could be concluded that most hotels in Ghana have the necessary foundation and the requisite knowledge to develop and implement performance management system. This is because the data revealed that 91.5% of the hotels set objectives and strategies to achieve them. 92.9% of them had culture and core value statements. Although the percentage of hotels that had mission statements, strategic plans and performance agreements was negligible, PMS is not new in Ghana. Some of the star-rated hotels practice it. In addition, the public sector, financial institutions, the private sector, not-for-profit organisations and other organisations are also practicing PMS. Hence, with some exposure, training and conscientisation, PMS could be implemented in the hotel industry. The effective implementation of PMS would improve employee engagement and productivity.

Although the practice of PMS is beset with some implementation challenges such as ineffective communication, biases, irregular feedback, etcetera that hamper its effectiveness and efficiency, and foreseen challenges that may be peculiar to hotels in Ghana including lack of strategic plans, performance agreements, verbal job descriptions instead of written, poor commitment from management, PMS is still important to the hotels when the necessary measures are established.

Although the results revealed that PMS, performance appraisal system and HR practices have a positive but weak significant relationship with employee engagement and productivity, hotel managers and HRM departments should introduce effective human resource management practices that would promote and enhance the relationship between the selected independent and employee engagement and productivity.

From the data the hotels studied practices the following types of performance appraisal system: Behavioural Checklist, Management by Objectives (mostly by managers), Straight Ranking Method and Rating Scale.

From the findings, it was clear that national culture plays a pivotal role in performance management system. Specifically, using national culture as a direct and mediating variable, the empirical analysis supported the variables. National culture mediates the relationship between (i) performance appraisal and employee engagement and productivity, and (ii) selected HR practices and employee engagement and productivity. National culture impacts positively and significantly on all the three selected constructs. As well as employee engagement and productivity.

In line with these results, it could be concluded that employees may raise outstanding performance when they are conversant with and feel part of the entire PMS process in their hotels. They may own the process and the sense of belonging could lead to unearthing their potential and enhance their productivity.

On the part of organisational culture, although it forms an integral part of PMS, the data did not support the three constructs. However, organisational culture has a direct impact on employee engagement and productivity, and the weak direct relationship that may exist is not supported by the output of the empirical analysis. Most of the hotels had culture and value statements and therefore it behooves the management of these hotels to emphasise their communication on organisational culture and values to the employees.

The study was relevant because it did not only expand academic knowledge in the field of human resource management, but also made a significant contribution to literature on performance management system in hotels. Suggesting some Ghanaian cultural elements that could enhance the successful implementation of PMS in hotels in Ghana. Additionally, this thesis answers earlier calls in literature to contextualise PMS by inculcating national culture in addition to organisational culture to its design and implementation (Aguinis, 2019; Guo et al., 2018; Abane & Phinaitrup, 2020; Ohemeng & Kamga, 2020).

With regards to the impact of the COVID-19 pandemic, if there is anything that the hotel industry has learnt, is to develop domestic tourism. If the Ghanaian economy had a thriving domestic tourism, it would have helped mitigate some of the negative impact of the pandemic on the industry especially, after the ban on gathering was lifted.

This research provides an opportunity for future empirical study into diverse aspects of PMS in hotels, employee performance, engagement and productivity. It also increases academic knowledge in performance management and human resource management in general.

4.1.1 Proposal for Further Studies

This research used mediation to determine how both national and organisational cultures could influence effective performance management system, performance appraisals and selected HR practices to result in employee engagement and productivity in the hotel industry. It is suggested that a future study could adopt a moderation model to explain the same. The present study used a cross-sectional survey design. Alternatively, a future study could adopt an extensive longitudinal study using a mixed-method approach to establish if an effective performance management system

influenced by both national and organisational cultures, practiced over time could result in employee engagement and productivity in the hospitality industry. Moreover, the number of HR officers and star-rated hotels selected for the qualitative study could be increased to gain more understanding of how PMS is practiced in hotels in Ghana. This thesis focused on the Greater Accra Region of Ghana. A further study could cover the hospitality and tourism industry of the entire country. Finally, studying PMS in the hotel industry in Ghana using the latent variables nexus was nonexistent in literature. It is therefore recommended that researchers in hospitality, tourism and human resource management could conduct several studies in this area to bridge the gap.

4.2. Recommendations

The first recommendation is to incorporate national and organisational culture in PMS in the hotel industry in Ghana. National culture can be incorporated into the performance management systems in the hotel industry in Ghana in several ways:

- **Employee engagement surveys:** Managers could conduct surveys to understand the cultural backgrounds and values of their employees and use that information to tailor their PMS to better align with their employees' needs and expectations. This may improve employee engagement and productivity.
- **Cultural training:** Management could provide cultural training to employees and managers to increase their understanding and appreciation of the hotels' key cultures, which would drive employee engagement and productivity. Special attention should be given to organisational culture since the findings revealed a weak relationship between organisational culture and the selected constructs.
- **Incorporating traditional values:** Managers could incorporate traditional values such as respect for the individual, the importance of community, and a strong work ethics into the performance management system.
- **Using language and communication appropriate to the culture:** Managers could use language and communication that is appropriate to the culture of their employees, which could help improve communication and foster mutual respect.
- **Assessing performance in the context of cultural norms:** managers could assess employee performance in the context of cultural norms, which can help create a more fair and effective performance management system.

Since organisational culture lays the foundation of employee behaviour and good teamwork. It could reduce limitations among teams, help in decision making and improve overall workflow. Both cultures are also a key factor in the success of the implementation of PMS.

While incorporating national and organisational culture into PMS could be beneficial, it's vital to consider the specific cultural practices and how they could be effectively integrated into the system without disrupting organisational goals and objectives. It is also key to involve employees in the process, to ensure that the cultural considerations are relevant and useful for them.

4.2.1 Rewarding and Sanctioning Personnel Based on How Well Guests Are Treated.

A hotel should implement financial incentives to foster an organisational focus on increasing the visitor experience. These benefits could take the form of bonuses determined, for instance, by the percentage rise in Net Promoter Score (NPS). A portion of each manager's annual incentive might be directly related to this metric for each manager who influences guest survey outcomes.

Employee incentives should be coordinated with business objectives and visitor requirements to ensure that a hotel's staff is increasingly focused on the demands of its visitors. Additionally, consider boosting employee morale by giving them greater tools and incentives to execute their duties. Equally, appropriate sanctions could be meted out to employees who constantly fault the system.

4.2.2 PMS cannot be effectively practised without a good appraisal system and other best human resource management practices such as training and development, rewards system, comprehensive company culture etc. Hotel managers and the HRM departments must work hand-in-hand to ensure a sound overall system.

4.2.3 Concerning the impact of the COVID-19 pandemic on the hotel industry, the ministry in charge of tourism and other government agencies should enact policies that would encourage, develop and enhance domestic tourism. This would increase patronage of the hotel industry locally and reduce the external shocks that affect it during incidents like the COVID-19 pandemic.

5. NEW SCIENTIFIC RESULTS

Performance management system has been a phenomenon adopted by many organisations and industries across the globe. It is a tool that covers several processes in an organisation, that include goal setting, regular feedback, consistent communication, employees' development plan and tracking employee performance. These characteristics allow managers and employees to have continuous feedback and effective communication with the propensity to enhance organisational outcomes. PMS gives organisations the capability of aligning employees' individual with organisational strategies so that everybody can work towards achieving a set of organisational goals. This study specifically focuses on performance management system and employee engagement and productivity in hotels with evidence from an emerging economy.

1. The novelty of this study starts from its inception in the sense that it is the first of its kind in Ghana, studying PMS in the hotel industry and using both national and organisational culture as mediators between the performance management - employee engagement and productivity nexus. This is nonexistent in literature. This study presented evidence that some of the star-rated hotels both local and international practice performance management systems. Some have been practicing for as long as 15 years, but it starts from the departmental level and cascades to the individual employees. It was also evident that some of the hotels that practice PMS, did not relate it to their strategic plans. It was also noted that the budget hotels did not have strategic plans which undoubtedly can have a significant effect on their operations. This research therefore unveils important information that provides opportunities to strengthen the governance arrangements of the hotel industry in Ghana in general.

Despite the importance of PMS and the contribution it stands to make in the hotel sector, literature showed limited research in this industry in Ghana. This comes with it, a significant knowledge gap. As such, this thesis raises awareness that researchers in hospitality, tourism and human resource management in Ghana should focus on addressing the gaps between theory and practice when it comes to performance management system.

2. This research adds significant knowledge about how PMS was practised in some of the star-rated hotels in the Greater Accra Region, when the implementation commenced and the challenges they were experiencing. Hence this thesis offers an opportunity for further studies in hotels across the entire country to identify the categories of hotels that practice

PMS, what they seek to achieve and the challenges they face. In addition, the outcome of this thesis offers hotel management and HR managers the opportunity to enact workable HR policies and practices to improve the design and implementation of PMS in the hospitality and tourism industry.

3. A significant finding the study revealed is the fact that certain Ghanaian cultures positively influence employee engagement and employee productivity when incorporated in the design and implementation of PMS. This is a novelty that opens opportunities for further investigations into the influence of national culture on employee engagement and productivity in other African countries.
4. It is novel to unravel the fact that national culture transcends into organisational cultures and as such when ignored could lead to negative consequences. Thus, the results indicate that more emphasis should be placed on organisational culture since it can significantly influence organisational outcomes.

6. REFERENCES

1. Abane, J. A. and Phinaitrup, B. A. (2020). The determinants of performance management outcomes in public organizations in Sub-Saharan Africa: the role of national culture and organizational subcultures. *Public Organization Review*, 20(3), pp.511-527.
2. Abane, J. A. and Brenya, E. (2021). The relationship between organizational environment antecedents and performance management in local government: evidence from Ghana. *Future Business Journal*, 7(1), pp.1-17.
3. Abdussamad, Z., Agyei, I. T., Döngül, E. S., Abdussamad, J., Raj, R. and Effendy, F. (2022). Impact of internet of things (IOT) on human resource management: a review. *Materials Today: Proceedings*, 56, pp.3534-3543. DOI: <https://doi.org/10.1016/j.matpr.2021.11.247>.
4. Aguinis, H. (2019). Performance Management for Dummies. *John Wiley & Sons*. ISBN 978-1-119-55765-4.
5. Ahmad, H. and Halim, H. (2017). Determining sample size for research activities. *Selangor Business Review*, pp.20-34.
6. Ahenkan, A., Tenakwah, E. S. and Bawole, J. N. (2018). Performance management implementation challenges in Ghana's local government system: Evidence from the Sefwi Wiawso Municipal Assembly. *International journal of productivity and performance management*.
7. Amirtharaj, S. M. D., Cross, S. K. R. and Vembar, V. (2011). HR concepts in hotel industry towards employee training and development. *Int J Hum Res*, 1, pp.44-56.
8. Anh Vu, T., Plimmer, G., Berman, E., & Ha, P. N. (2022). Performance management in the Vietnam public sector: The role of institution, traditional culture and leadership. *International Journal of Public Administration*, 45(1), pp.49-63. DOI: <https://doi.org/10.1080/01900692.2021.1903499>.
9. Asare-Bediako, K. (2013). Professional skills in Human Resource Management, 3rd. ed. pp.218-231. ISBN 978-9988 – 0 -1094 X.
10. Awan, S. H., Habib, N., Shoaib Akhtar, C. and Naveed, S. (2020). Effectiveness of performance management system for employee performance through engagement. *SAGE open*, 10(4), p.2158244020969383.
11. Bawole, J. N. and Ibrahim, M. (2017). Value-for-money audit for accountability and performance management in local government in Ghana. *International Journal of Public Administration*, 40(7), pp.598-611.
12. Bhatnagar, J., Puri, R. and Jha, H. M. (2004). Managing innovative strategic HRM: The

- balanced scorecard performance management system at ITC hotels. *South Asian Journal of Management*, 11(4), pp.92-110.
13. Boadu, F., Dwomo-Fokuo, E., Boakye, K. J. and Frimpong, O. A. (2014). Employee appraisal and performance in the hospitality industry. *Research in Business and Management*, 1(2), pp.146-165.
 14. Boella M. J. and Goss-Turner S. (2019). *Human Resource Management in the Hospitality Industry*. Routledge. ISBN 9781138338883.
 15. Boon, C., Eckardt, R., Lepak, D. P. and Boselie, P. (2018). Integrating strategic human capital and strategic human resource management. *The International Journal of Human Resource Management*, 29(1), pp.34-67.
 16. Brown, T. A. (2006). *Confirmatory factor analysis for applied research*. New York: Guilford Press.
 17. Brown, M. (2019). Understanding Performance Appraisal: Supervisory and Employee Perspectives. *The SAGE Handbook of Human Resource Management*, p.195.
 18. Byrne, B. M. (2001). *Structural equation modeling with Amos: Basic concepts, applications, and programming*. Mahwah, NJ: Erlbaum.
 19. Cameron, K.S. and Whetten, D.A., 1981. Perceptions of organizational effectiveness over organizational life cycles. *Administrative Science Quarterly*, pp.525-544.
DOI: <https://doi.org/10.2307/2392338>.
 20. Cameron, K. S., & Quinn, R. E. (2011). *Diagnosing and changing organizational culture: Based on the competing values framework*. Reading, MA: Jossey Bass.
 21. Chaokromthong, K. and Sintao, N. (2021). Sample size estimation using Yamane and Cochran and Krejcie and Morgan and green formulas and Cohen statistical power analysis by G* Power and comparisons. *Aphait International Journal*, 10(2), pp.76-86.
 22. Chen, Y. C., Wang, W. C. and Chu, Y.C. (2011). A Case Study on the Business Performance Management of Hilton Hotels Corp. *International Business Research*, 4(2), p.213.
 23. Cho, I. and Payne, S. C. (2016). Other important questions: When, how, and why do cultural values influence performance management?. *Industrial and Organizational Psychology*, 9(2), pp.343-350.
 24. Chowdhury, M. F. (2011). Performance management practices in organizations operating in Bangladesh: A deeper examination. *World Review of Business Research*, 1(2), pp.153-167.
 25. Collings, D. G., McMackin, J., Nyberg, A. J. and Wright, P. M. (2021). Strategic human resource management and COVID-19: Emerging challenges and research opportunities. *Journal*

of Management Studies.

26. Deloitte (2020). Impact of COVID-19 on the hospitality industry and its effect on audit. Retrieved from [<https://www2.deloitte.com/xe/en/pages/about-deloitte/articles/the-grind/impact-covid-19-hospitality-industry-effect-audit.html>]. Accessed on 30/03/2021.
27. Deri, M. N., Zaazie, P. and Bazaanah, P. (2021). Turnover intentions among hotel employees in the Accra metropolis of Ghana. *African Journal of Hospitality, Tourism and Leisure*, 10(1), pp.238-255.
28. DeVellis, R. F. (2012). *Scale development theory and applications* (3rd Ed.). Thousand Oaks, CA: Sage.
29. Dube, K., Nhamo, G. and Chikodzi, D. (2020). COVID-19 Cripples' Global Restaurant and Hospitality Industry. *Current Issues in Tourism*, pp.1-4.
30. Ferreira, A., Oiley D. (2009). *The design and use of performance management systems: an extended framework for analysis. Manage Account Research (December):263–282.*
31. Ghauri P. and Gronhaug K. (2002). *Research Methods in Business Studies: A Practical Guide* (2nd edition), *Pearson Education Limited*. ISBN 0273651102.
32. Girma, S. (2016). 'Assessing Employees Performance Management System of Hilton Addis Ababa Hotel'. Addis Ababa University Retrieved from [<http://etd.aau.edu.et/handle/123456789/9789>]. Accessed Oct. 24, 2020.
33. Gruman, J. A. and Saks, A. M. (2011). Performance management and employee engagement. *Human resource management review*, 21(2), pp.123-136. DOI: <https://doi.org/10.1016/j.hrmr.2010.09.004>.
34. Guo, Q., Liu, Z., Li, X. and Qiao, X. (2018). Indulgence and long-term orientation influence prosocial behavior at national level. *Frontiers in psychology*, 9, p.1798. DOI: <https://doi.org/10.3389/fpsyg.2018.01798>.
35. Hair, J. F., Sarstedt, M., Ringle, C. M., & Gudergan, S. P. (2018). *Advanced issues in partial least squares structural equation modeling (PLS-SEM)*. Thousand Oaks, CA: Sage.
36. Hans-Peter B. (2014). *Performance Management A Handbook for Developing and Implementing Effective Performance Management Systems in Myanmar Banks*, Deutsche Gesellschaft für Internationale Zusammenarbeit (GIZ) GmbH.
37. Hardiyanti, G. R., Aima, M. H. and Ridwan, M. (2022). The Influence of Corporate Culture and Transformational Leadership against Employee Performance Mediated by Employee Engagement at PT PLN (PERSERO) UP3 KEBON JERUK. *Dinasti International Journal of Education Management and Social Science*, 3(3), pp.373-391. DOI:

<https://doi.org/10.31933/dijemss.v3i3>.

38. Hassan, Q., Mubeen, N., Ali, S. and Sajjid, N. (2022). Job Satisfaction through Performance Appraisal: Moderating Role of Locus of Control. *International Journal of Management Research and Emerging Sciences*, 12(3).
39. Hervie, D. M., Tatár, E. and Illés, C. B. (2020). A Comparative Study of the Importance of Tourism and Hotel Sector in Ghana and Africa. *3rd International Conference Contemporary Issues in Theory and Practice of Management CITPM*, Częstochowa, Poland.
40. Hofstede, G. (2011). Dimensionalizing Cultures: The Hofstede Model in Context. Online Readings in Psychology and Culture, 2(1), DOI: <https://doi.org/10.9707/2307-0919.1014>.
41. Hongal, P. and Kinange, U. (2020). A study on talent management and its impact on organization performance-an empirical review. *International Journal of Engineering and Management Research*, 10.
42. Hospitality Industry in Ghana (2020, December 29). Retrieved from [<https://study.com/academy/lesson/hospitality-industry-in-ghana.html>]. Access. on 04.01.2021.
43. HTI Consulting (2017). Accra Hospitality Market. Retrieved from [<https://www.hticonsulting.co.za/accra-hospitality-market/>]. (Accessed on March 28, 2022).
44. Idrus S., Jihan, Rahman A. S., Arta D. N. C., Kespondiar T. (2023). The Evolution of Human Resource Management: The Necessity of Facing The Industrial Revolution 4.0. The Evolution of Human Resource Management: The Necessity of Facing The Industrial Revolution 4.0, *Jurnal Ilmiah Manajemen*, Vol. 4 No. 1, 2023 4(1), pp.91-97.
45. International Finance Corporation (2016). A hotel is not a place to sleep - IFC Investments in High-Quality Hotels: Promoting jobs, business infrastructure, tax revenue and local supply chains, World Bank Group.
46. Jain, S. and Gautam, A. (2014). Performance management system: A strategic tool for human resource management. *Prabandhan Guru*, 5, pp.28-32.
47. Jelínková, L. (2017). Factors influencing the implementation and continuous improvement of the performance management system. *KnE Social Sciences*, pp.242-256.
48. Jöreskog, K. G., & Sörbom, D. (1986). LISREL VI: Analysis of linear structural relationships by maximum likelihood, instrumental variables, and least squares methods. Skokie, IL: Scientific Software International, Inc.
49. Kaupa, S. and Atiku, S. O. (2020). Challenges in the implementation of performance management system in Namibian public sector. *International Journal of Innovation and Economic Development*, 6(2), pp.25-34.

50. Khan, M. A. and Law, L. S. (2018). The role of national cultures in shaping the corporate management cultures: A three-country theoretical analysis. In *Organizational Culture*. IntechOpen.
51. Kichigina, A. (2017). Challenges in the implementation of performance management: case study of the Russian public services, Krasnoyarsk City (*Doctoral dissertation, London Metropolitan University*).
52. Kivunja, C. and Kuyini, A. B. (2017). Understanding and applying research paradigms in educational contexts. *International Journal of higher education*, 6(5), p.26-41.
DOI: <https://doi.org/10.5430/ijhe.v6n5p26>.
53. Kline, R. (1998), Principles and practice of structural equation modelling, Guilford Press, New York.
54. Kline, R. B. (2015). Principles and practice of structural equation modeling (4th ed.). New York, London: Guilford Press.
55. Lee, J., Chiang, F. F., Van Esch, E. and Cai, Z. (2018). Why and when organizational culture fosters affective commitment among knowledge workers: the mediating role of perceived psychological contract fulfilment and moderating role of organizational tenure. *The International Journal of Human Resource Management*, 29(6), pp.1178-1207.
DOI: <https://doi.org/10.1080/09585192.2016.1194870>.
56. Levy, P. E., Tseng, S. T., Rosen, C. C. and Lueke, S. B. (2017). Performance management: A marriage between practice and science—Just say “I do”. In *Research in personnel and human resources management* (pp. 155-213). Emerald Publishing Limited.
57. Lohmöller, J. B. (1989). Predictive vs. Structural Modeling: PLS vs. ML. In: Latent variable path modeling with partial least squares. Heidelberg, Germany: Physical.
58. Mabey, C., Salaman, G. and Storey, J. (1999). Human Resource Management: A Strategic Introduction. 2nd Edition. *Blackwell Publishers Ltd*
59. Macke, J. and Genari, D. (2019). Systematic literature review on sustainable human resource management. *Journal of cleaner production*, 208, p.806-8... ISBN: 978-3-7908-2188-8.
60. Makori, C. (2014). Performance management and competitiveness of four- and five-star hotels in Nairobi-Kenya (Doctoral dissertation, University of Nairobi).
61. Malik, A., Budhwar, P., Patel, C. and Laker, B. (2021). Holistic indigenous and atomistic modernity: Analyzing performance management in two Indian emerging market multinational corporations. *Human Resource Management*, 60(5), pp.803-823.
62. Mangipudi, M. R., Prasad, K. D. V. and Vaidya, R. (2019). Employee Performance as

- Function of Performance Management System: An Empirical Study Information Technology Enabled Services Companies around Hyderabad. *European Journal of Business and Management Research*, 4(4).
63. Meilani, D. and Anugrah, I. (2015). The Design of Hotel Performance Management System in Padang. In Proceedings of the *International MultiConference of Engineers and Computer Scientists* (Vol. 2).
 64. Plaček, M., Nemeč, J., Ochrana, F., Půček, M., Krápek, M. and Špaček, D. (2020): Do performance management schemes deliver results in the public sector? Observations from the Czech Republic, *Public Money & Management*, DOI: <https://doi.org/10.1080/09540962.2020.1732053>.
 65. Moletsane, M., Tefera, O. and Migiro, S. (2019). The Relationship between Employee Engagement and Organisational Productivity of Sugar Industry in South Africa: The Employees' Perspective. *African Journal of Business & Economic Research*, 14(1).
 66. Mulaik, S. A., James, L. R., Van Alstine, J., Bennett, N., Lind, S., & Stilwell, C. D. (1989). Evaluation of goodness-of-fit indices for structural equation models. *Psychological Bulletin*, 105(3), 430–445. DOI: <https://doi.org/10.1037/0033-2909.105.3.430>.
 67. Nkomo, D. (2014). Developing a dictionary culture through integrated dictionary pedagogy in the outer texts of South African school dictionaries: the case of Oxford Bilingual School Dictionary: IsiXhosa and English. *Lexicography*, 2, pp.71-99.
 68. O'Donovan, D. and Linehan, M. (2014). Performance Management Systems in Irish Hotels: Is Adaptation Necessary to Cater for non-Irish Employees? *Irish Business Journal*, 9(1), pp.84-93.
 69. Oduro-Nyarko, C. (2013). Assessment of Performance Appraisal Techniques by Small and Medium Size Hotels in Central Ayawaso Metropolitan Area. *Assessment*, 3(12), pp.9-15.
 70. Ohemeng, F.L.K., Amoako Asiedu, E. and Obuobisa-Darko, T. (2018). Giving sense and changing perceptions in the implementation of the performance management system in public sector organisations in developing countries. *International Journal of Public Sector Management*, 31(3), pp.372-392.
 71. Ohemeng, F.L. and Kamga, O. (2020). Administrative leaders as institutional entrepreneurs in developing countries: A study of the development and institutionalization of performance management in Ghana's public service. *Public Administration and Development*, 40(1), pp.87-100. DOI: <https://doi.org/10.1002/pad.1867>.
 72. O'riordan, J. (2017). The practice of human resource management.
 73. Otoo, F. N. K. and Mishra, M. (2018). Impact of human resource management (HRM)

- practices on hotel industry's performance: The mediating role of employee competencies. *Indian Journal of Commerce and Management Studies*, 9(2), pp.17-29. DOI: <https://doi.org/10.18843/ijcms/v9i2/03>.
74. Oxford Business Group Report (2019). The Report, Ghana (2019). Tourism in Ghana. United Arab Emirates. *802 Publishing Pavilion*, Dubai Production City.
 75. Owusu Ansah, M. and Louw, L. (2019). The influence of national culture on organizational culture of multinational companies. *Cogent Social Sciences*, 5(1), p.1623648. DOI: <https://doi.org/10.1080/23311886.2019.1623648>.
 76. Pandita, D. and Ray, S. (2018). "Talent management and employee engagement – a meta analysis of their impact on talent retention", *Industrial and Commercial Training*, Vol. 50 No. 4, p. 185-199. DOI: <https://doi.org/10.1108/ICT-09-2017-0073>.
 77. Patel, B., Patel, A. and Sharma, A. (2020). Examining the Role of HR Professionals in Developing Efficient and Effective Performance Management Systems. *AAYAM: AKGIM Journal of Management*, 10(1), pp.17-24.
 78. Plaček, M., Nemeč, J., Ochrana, F., Půček, M., Křápek, M. and Špaček, D. (2021). Do performance management schemes deliver results in the public sector? Observations from the Czech Republic. *Public Money & Management*, 41(8), pp.636-645. DOI: <https://doi.org/10.1080/09540962.2020.1732053>.
 79. PossibleWorks (2023). Employee Engagement and Productivity – how are they related? Retrieved from [<https://possibleworks.com/blog/employee-engagement-and-productivity/>]. Accessed on (March 20, 2023).
 80. Raj, K. and Verma, A. (2020). Impact of Performance Management System on Employees Job Satisfaction in Hotel Industry. *JOHAR*, 15(1), p.1.
 81. Rusu, G., Avasilcăi, S. and Huțu, C. A. (2016). Organizational context factors influencing employee performance appraisal: A research framework. *Procedia-Social and Behavioral Sciences*, 221, pp.57-65.
 82. Saeidi, P., Mardani, A., Mishra, A.R., Cajas, V.E.C. and Carvajal, M.G. (2022). Evaluate sustainable human resource management in the manufacturing companies using an extended Pythagorean fuzzy SWARA-TOPSIS method. *Journal of Cleaner Production*, 370, p.133380. DOI: <https://doi.org/10.1016/j.jclepro.2022.133380>.
 83. Saks, A. M. (2022). Caring human resources management and employee engagement. *Human Resource Management Review*, 32(3), p.100835.
 84. Saluy, A.B., Abidin, Z., Djamil, M., Kemalasarı, N., Hutabarat, L., Pramudena, S.M. and

- Endri, E. (2021). Employee productivity evaluation with human capital management strategy: The case of covid-19 in Indonesia. *Academy of Entrepreneurship Journal*, 27(5),1-9.
85. Sasu, D. D. (2021). Annual Contribution of Hotels and Restaurants to GDP in Ghana 2013-2020. Retrieved from [<https://www.statista.com/statistics/1271615/annual-contributions-of-hotels-and-restaurants-to-gdp-in-ghana/>]. (Accessed on 28-03-2022).
86. Sasu, D. D. (2022). Employed population in accommodation and food services in Ghana 2021, by region. Retrieved from [<https://www.statista.com/statistics/1289460/employees-in-accommodation-and-food-services-in-ghana-by-region/>]. (Accessed on 24-06-2022).
87. Sasu, D. D. (2022). Largest hotels in Ghana 2022, by region and number of rooms. Retrieved from [<https://www.statista.com/statistics/1289957/leading-hotels-in-ghana-by-region-and-number-of-rooms/>]. (Accessed on 24-06-2022).
88. Sawalha, N., Zaitouni, M. and ElSharif, A. (2012). Corporate culture dimensions associated with organizational commitment: An empirical study. *Journal of Applied Business Research (JABR)*, 28(5), pp.957-976.
89. Sepahvand, R. and Bagherzadeh Khodashahri, R. (2021). Strategic human resource management practices and employee retention: A study of the moderating role of job engagement. *Iranian Journal of Management Studies*, 14(2), pp.437-468.
90. Shin, S. K. (2005). Did they take the same test? Examine language proficiency and the structure of language tests. *Language Testing*, 22(1), 31–57. DOI: <https://doi.org/10.1191/0265532205lt296oa>.
91. Singh, A. (2019). Association between organizational norms and employee productivity in higher education. *Journal of Applied Research in Higher Education*, 12(2), 271–295. DOI: <https://doi:10.1108/jarhe-01-2019-0014>.
92. Sisa, E. (2014). Implementation of the performance management system in the Ministry of Foreign Affairs and International Cooperation of the Botswana Public Service (*Doctoral dissertation*, University of South Africa).
93. Sloan, A. and Bowe, B. (2014). Phenomenology and hermeneutic phenomenology: The philosophy, the methodologies, and using hermeneutic phenomenology to investigate lecturers' experiences of curriculum design. *Quality & Quantity*, 48, pp.1291-1303.
94. Sopiah, S., Kurniawan, D. T., Nora, E. and Narmaditya, B. S. (2020). Does talent management affect employee performance?: The moderating role of work engagement. *The Journal of Asian Finance, Economics and Business*, 7(7), pp.335-341.
95. Statista Research Department (2020). Impact of coronavirus (COVID-19) on RevPar of hotels in

- Europe 2020. Retrieved from
[\[https://www.statista.com/statistics/1105462/impact-of-covid-19-on-hotel-revpars-in-europe/\]](https://www.statista.com/statistics/1105462/impact-of-covid-19-on-hotel-revpars-in-europe/).
 Accessed on November 05, 2020.
96. Suherli, E., Hanggoro, N. W. and Herawan, T. (2018). Impact of Performance Management Systems on Employee Performance. *International Journal of Science and Research*. ISSN: 2319-7064.
 97. Sullivan, A. and Calderwood, L. (2016). Surveys: Longitudinal, cross-sectional and trend studies. In D. Wyse, N. Selwyn, E. Smith, & L. E. Suter (Eds.), *The BERA/SAGE Handbook of educational research* (pp. 395–415). Sage.
 98. Szydło, J. and Grześ-Bukłaho, J. (2020). Relations between national and organisational culture—Case study. *Sustainability*, 12(4), p.1522.
 99. Thams, A., Zech, N., Rempel, D. and Ayia-Koi, A. (2020). An initial assessment of economic impacts and operational challenges for the tourism & hospitality industry due to COVID-19 (No. 2/2020). *IUBH Discussion Papers-Tourismus & Hospitality*.
 100. Ugyel, L. (2021). Relationship between public sector reforms and culture: The implementation of NPM-related performance management reforms in a collectivist and risk-averse culture. *Public Administration and Development*, 41(5), pp.257-266.
 101. Valecha, N. (2022). Transforming human resource management with HR analytics: A critical Analysis of Benefits and challenges. *International Journal for Global Academic & Scientific Research*, 1(2), pp.56-66. DOI: <https://doi.org/10.55938/ijgasr.v1i2.16>.
 102. Varma, A., Budhwar, P. S. and DeNisi, A. (2008) Performance management systems: A global perspective, Routledge global human resource management series, *Routledge* DOI: <https://doi.org/10.4324/9780203885673>.
 103. Varma, A., Budhwar, P.S. and DeNisi, A. eds. (2023). Performance management systems: A global perspective. Rev ed. *Routledge*. ISBN:978-1-330818-0. DOI: <https://doi.org/10.4324/9781003306849>.
 104. Wang, Y., Farag, H. and Ahmad, W. (2021). Corporate culture and innovation: A tale from an emerging market. *British Journal of Management*, 32(4), pp.1121-1140.
 105. World Population Review (2022). Accra Population 2022. Retrieved from [\[https://worldpopulationreview.com/world-cities/accra-population.\]](https://worldpopulationreview.com/world-cities/accra-population.). Accessed on March 28, 2022.
 106. WTTC (2021), Economic Impact Report. Retrieved from [\[https://wttc.org/Research/Economic-Impact\]](https://wttc.org/Research/Economic-Impact), Accessed on 06/03/2021.

7. DISSERTATION-RELATED PUBLICATIONS BY AUTHOR

Publications in scientific journals

1. **Hervie, D. M.**, Amoako-Atta, E., Hossain Md. B., Illés C. B. and Dunay A. (2022). Impact of COVID-19 Pandemic on Hotel Employees in the Greater Accra Region of Ghana. *SUSTAINABILITY*, 14:(5) Paper: 2509, 18 p.
2. Hossain, Md. B., Al-Hanakta. R. Y., **Hervie D. M.**, Nor M. K., Illes C.B. (2022). Exploring the Key Success Factors for Sustainable E-Commerce Adoption in SMEs. *POLISH JOURNAL OF MANAGEMENT STUDIES*, 25:(1) pp. 162-178.
3. **Hervie, D. M.**, Illés C. B. and Dunay A. (2021). Performance Management System (PMS) Practices in Hotels in the Greater Accra Region of Ghana. *SELYE E-STUDIES* 12:(1) pp. 4-15.
4. **Hervie D. M.**, Winful, C. E., Tsagli, S. K. (2021). Valorization of Plastic Waste in Ghana: The Circular Approach. *INTERNATIONAL JOURNAL OF SUSTAINABLE ECONOMIES MANAGEMENT, (IJSEM)*, 10:(2), pp. 31-45.
5. **Hervie, D. M.**, Illés, C.B., Dunay, A. and Khalife, M.A. (2021). Bibliometric Analysis of Human Resource Management (HRM) in the Hospitality and Tourism Industry. *JOURNAL OF MANAGEMENT*, 37(1). DOI: <http://doi.org/10.38104/vadyba.2021.1.06>.
6. Winful, C. E., Sarpong Jnr. D., **Hervie D. M.** and Larbi D. (2020). Human capital and stock market performance of some selected emerging economies. *JOURNAL OF ECONOMICS AND INTERNATIONAL FINANCE*, 12:(4), pp. 223-232.

Publications in book chapters

1. **Hervie D. M.**, Potháczky Rácz, I. (2021). HRM a fejlődő, átalakuló és fejlett országokban, és a COVID–19: Ghána. [HRM in developing, transitioning and developed countries and COVID-19: Ghana.] In: Kőműves, Zs. S.; Szabó, K.; Szabó-Szentgróti, G.; Poór, J. (ed.) Koronavírus-válság kihívások és HR-válaszok – hazai és nemzetközi tapasztalatok 2020 [Coronavirus crisis, challenges and HR responses – national and international experiences 2020], Wolters Kluwer Hungary, Budapest, 318 p. Online. *Wolters Kluwer Hungary*. ISBN: 978 963 594 009 7

Publications in conference proceedings

1. **Hervie, D. M.**; Illés, B. Cs.; Dunay, A. (2023). Managing remote and hybrid workforce: benefits, challenges, and way forward in Africa. pp. 106-117. In: Albrychiewicz-Słocińska, A.; Karczewska, A.; Skiba, Ł. (eds.) 12th International Conference on Management - "Sustainability-Security-Quality": Book of Proceedings. Wydawnictwo Politechniki Czestochowskiej, Częstochowa, Poland, 275 p. <http://doi.org/10.17512/CUT/9788371939563/17>.

2. **Hervie, D. M.;** Dunay, A. (2021): The Impact of Covid-19 on Teaching and Learning: The African Perspective. pp. 114-119. In: Ivanova, M.; Nikoloski, D.; Yilmaz, R. (eds.) Proceedings: XV. International Balkan and Near Eastern Social Sciences Congress. Series on Economics, Business and Management. 2021.05.29-30., Plovdiv - Пловдив, Bulgaria: Visshe-uchilishhe-po-agrobiznes-i-razvitie-na-regionite-Plovdiv, University St. Kliment Ohridski, Faculty of Economics and Business Administration 1, 540 p.
3. **Hervie, D. M.;** Illés, B. Cs.; Dunay, A. (2020). Foreign direct investments and foreign influences in Ghana. pp. 112-121. In: Magda, R.; Katekhaye, D (eds.) Challenges and changes under the shadow of COVID-19: Conference proceedings of the 7th VUA YOUTH scientific session, Szent István University, Gödöllő, Hungary, 332 p.
4. **Hervie, D. M.;** Illés, B. Cs. (2020). Analysis of Factors Contributing to Unemployment. pp. 122-127. In Ghana. In: Dimitrov, D. K.; Nikoloski, D.; Yilmaz R. (eds.) Proceedings of XIV. International Balkan and Near Eastern Social Sciences Congress Series on Economics, Business and Management, Plovdiv, Bulgaria, September 26-27, 2020
5. **Hervie, D. M.;** Törőné Dunay, A. (2020). The History And Impact of Industrialization in Ghana. pp. 117-121. In Ghana. In: Dimitrov, D. K.; Nikoloski, D.; Yilmaz R. (eds.) Proceedings of XIV. International Balkan and Near Eastern Social Sciences Congress Series on Economics, Business and Management, Plovdiv, Bulgaria, September 26-27, 2020
6. **Hervie, D. M.;** Daróczy, M. (2020). The circular economy approach: Transforming plastic waste into pavement blocks in Ghana. pp. 103-109. In: Korombel, A.; Ławińska, O.; Okręglicka, M. (eds.) Proceedings of the 3rd International Conference Contemporary Issues in Theory and Practice of Management - CITPM 2020. Wydawnictwo Politechniki Czestochowskiej, Częstochowa, Poland, 293 p.
7. **Hervie, D. M.;** Tatár, E.; Illés, B. Cs. (2020). A comparative study of the importance of tourism and hotel sector in Ghana and Africa. pp. 110-117. In: Korombel, A.; Ławińska, O.; Okręglicka, M. (eds.) Proceedings of the 3rd International Conference Contemporary Issues in Theory and Practice of Management - CITPM 2020. Wydawnictwo Politechniki Czestochowskiej, Częstochowa, Poland, 293 p.